



SUBMITTAL DATA – CEILING CASSETTE
MPC012S4S-1P – M22A012S4-2P
 SINGLE ZONE MINI-SPLIT HEAT PUMP

Job: _____
Location: _____
Schedule No.: _____
System Designation: _____

Engineer: _____
Architect: _____
Date: _____
For: Reference Approval Review Construction

FEATURES

Outdoor Unit: MPC012S4S-1P

Indoor Unit: M22A012S4-2P



- DC Inverter Control
- Compressor Overcurrent Protection
- Base Dancer
- Defrost Control

- 360 Airflow Panel
- Pre Heat Function
- Auto Restart
- Built-In Condensate Pump
- Three Selectable Fan Speeds
- Flare Connections
- LED Readout/Infrared Receiver Panel
- Wireless Remote Included

PIPING

Line Set and Elevation Guidelines	
Maximum Line Set Length ft. (m)	98 (30)
Maximum Elevation - Outdoor Unit Below/Above Indoor Unit ft. (m)	66 (20)
Liquid Line Set Diameter (in.)	1/4
Gas Line Set Diameter (in.)	1/2
Pre-Charged (ft.)	15
Additional Charge of Refrigerant (oz/ft.)	0.16

PRODUCT WARRANTY

Compressor – Twelve year limited warranty*
 All other covered components - Twelve year limited warranty*
 *Product registration required

OPTIONAL ACCESSORIES

Non-Programmable Controller (M0STAT61Q-1)
 Programmable Controller (M0STAT64Q-2)



NOTE – Due to Lennox' ongoing commitment to quality, Specifications, Ratings, and Dimensions are subject to change without notice and without incurring liability. Improper installation, adjustment, alteration, service or maintenance can cause property damage or personal injury. Installation and service must be performed by a qualified installer and servicing agency.



SUBMITTAL DATA - CEILING **CASSETTE**

MPC012S4S-1P - M22A012S4-2P

SINGLE ZONE MINI-SPLIT HEAT PUMP

OUTDOOR SPECIFICATIONS

PERFORMANCE

Cooling Capacity (Min/Max) (Btu/h) ¹	12,000 (2,800/14,100)
EER	14
SEER	22.0
Heating Capacity (Min/Max) (Btu/h) ¹	12,000 (1,950/14,600)
HSPF	10.6
Outdoor Fan Total Air Volume (CFM)	1,295
Ambient Temperature Operating Range	
Cooling	-13°F - 122°F
Heating	-13°F - 86°F

ELECTRICAL DATA

Power Supply (V/Hz/Φ)	208-230/60/1
Minimum Circuit Ampacity (A)	13
Maximum Overcurrent Protection (A)	15
Outdoor Fan Motor RLA (A)	0.60
Compressor RLA (A)	6.4
No. of Compressors	1

GENERAL DATA

Connection Ratio (%)	100%
Max. # of Indoor Units	1 unit
Sound Data (dBA) - Cooling/Heating	53.5/53.5
Refrigerant type	R-410A
Factory refrigerant charge	2 lbs. 6 oz.

DIMENSIONS

Unit Dimensions (in)	Height	21-7/8
	Width	32-7/8
	Depth	12-3/8
Shipping Weight (lb)		69
Net Weight (lb)		64

NOTES

- Cooling and Heating Capacity data is rated at the following conditions:
 Cooling: 80°FDB / 67°FWB Indoor, 95°FDB Outdoor
 Heating: 70°FDB Indoor, 47°FDB / 43°FWB Outdoor

OUTDOOR DIMENSIONAL DRAWINGS - INCHES (MM)

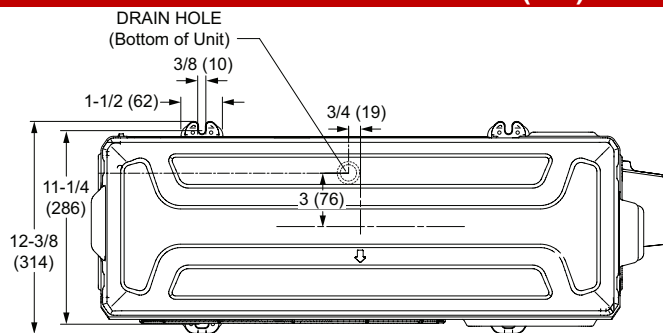

TOP VIEW

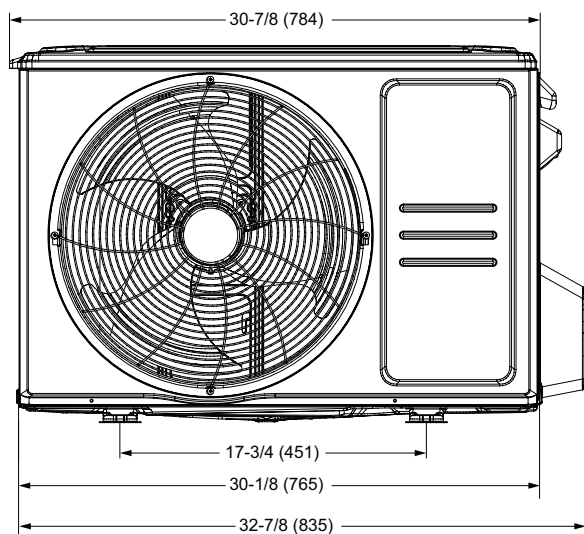

FRONT VIEW

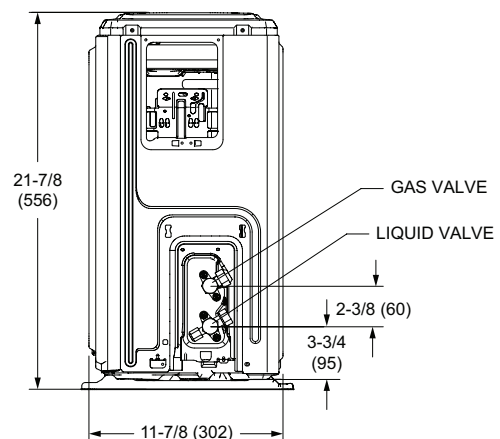

SIDE VIEW

NOTE - Due to Lennox' ongoing commitment to quality, Specifications, Ratings, and Dimensions are subject to change without notice and without incurring liability. Improper installation, adjustment, alteration, service or maintenance can cause property damage or personal injury. Installation and service must be performed by a qualified installer and servicing agency.



SUBMITTAL DATA - CEILING CASSETTE

MPC012S4S-1P - M22A012S4-2P

SINGLE ZONE MINI-SPLIT HEAT PUMP

INDOOR SPECIFICATIONS

PERFORMANCE

Airflow (CFM)	High	380
	Medium	310
	Low	260
Sound Pressure (dBA)	High	43
	Medium	39
	Low	36

ELECTRICAL DATA

Power Supply (V/Hz/Φ)	Supplied by ODU
Rated load amps (RLA)	1
Power Output (W)	46

DIMENSIONS

Unit Dimensions (in)	Height	10-3/8
	Width	21-1/2
	Depth	20-5/8

Unit Net/Shipping Weight (lb)	36/41
-------------------------------	-------

PIPING

Liquid/Gas O.D. Flare (in.)	1/4 , 1/2
Drain Connection O.D. (in.)	1

Required Component - Ordered Separately

Cassette Panel	13 x 04 (MOSTAT62Q-1)
Net/Shipping Weight (lb)	6/10

INDOOR DIMENSIONAL DRAWINGS - INCHES (MM)

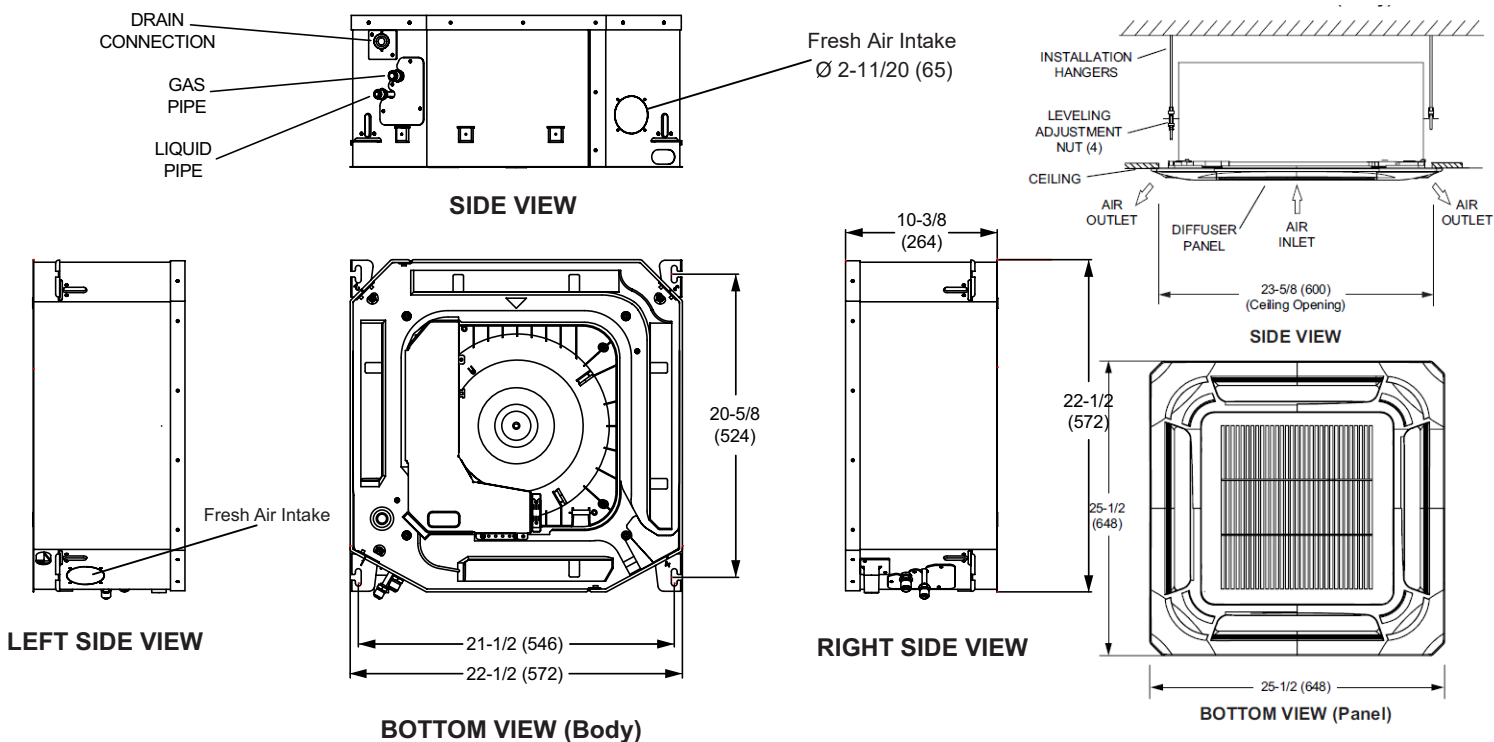

NOTE - Due to Lennox' ongoing commitment to quality, Specifications, Ratings, and Dimensions are subject to change without notice and without incurring liability. Improper installation, adjustment, alteration, service or maintenance can cause property damage or personal injury. Installation and service must be performed by a qualified installer and servicing agency.