



SUBMITTAL DATA - **OUTDOOR UNIT**

VPA072H4M-2G

VRF HEAT PUMP

Job: _____
Location: _____
Schedule No.: _____
System Designation: _____

Engineer: _____
Architect: _____
Date: _____
For: Reference Approval Review Construction

FEATURES

- Two-pipe heat pump
- Accelerated complete coil defrost
- Hinged electrical box for ease of maintenance
- High efficiency DC Inverter scroll compressor
- Intelligent Duty Cycle operation
- Night Silent operation

WARRANTY

- Compressor - 10 year limited warranty
 - All other components - 10 year limited warranty
- *See warranty for details

SPECIFICATIONS

PERFORMANCE

Cooling Capacity ¹ (Btu/h)	Nominal	72,000
	Rated ²	69,000
EER	Ducted	12.00
	Non-Ducted	13.80
IEER	Ducted	22.70
	Non-Ducted	23.60
Heating Capacity ¹ (Btu/h)		77,000
	COP47	
	Ducted	3.69
	Non-Ducted	4.25
COP17	Ducted	2.41
	Non-Ducted	2.65

ELECTRICAL DATA

Power Supply ³ (V/Hz/Ph)	460/60/3
Minimum Circuit Ampacity (A)	18.7
Maximum Overcurrent Protection (A)	30
Compressor RLA (A)	14
No. of Compressors	1
Outdoor Fan Power Input (W)	260/260
Outdoor Fan FLA (A)	0.6/0.6

GENERAL DATA

Connection Ratio	50% to 130%
Max. # of Indoor Units	13 units
Sound Pressure Level (dBA)	59
Outdoor Fan Air Volume (cfm)	7215
Refrigerant type	R-410A
Factory refrigerant charge	28 lbs. 11 oz.

DIMENSIONS

Unit Dimensions (in)	Height	63-1/8
	Width	49-1/2
	Depth	30-1/8
Liquid Pipe Connection (in)		1/2
Gas Pipe Connection (in)		7/8
Shipping Weight (lb)		668
Net Weight (lb)		631



NOTES

1. Cooling and Heating Capacity data is rated at the following conditions:
Cooling: 80°FDB / 67°FWB Indoor, 95°FDB Outdoor
Heating: 70°FDB Indoor, 47°FDB / 43°FWB Indoor
2. Complies with AHRI 1230-2014 testing standards
3. Operating Voltage Range: 423V to 497V





SUBMITTAL DATA - **OUTDOOR UNIT**
VPA072H4M-2G
VRF HEAT PUMP

DIMENSIONS - INCHES (MM)

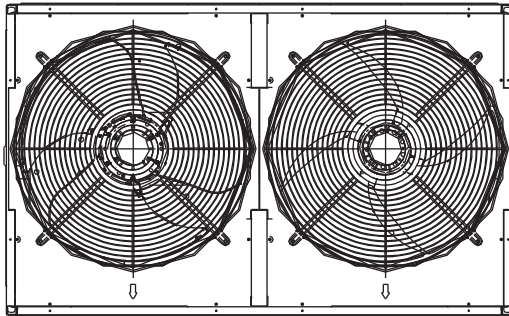

TOP VIEW

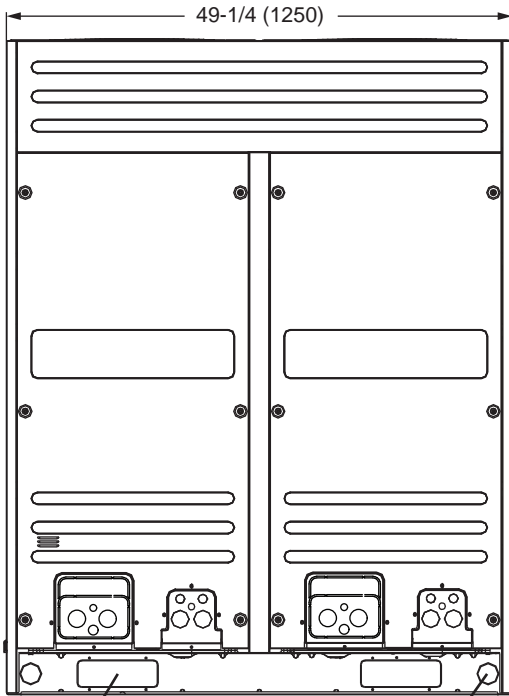

FRONT VIEW
 FORKLIFT SLOT (BOTH SIDES) LIFTING HOLES (FOR RIGGING)

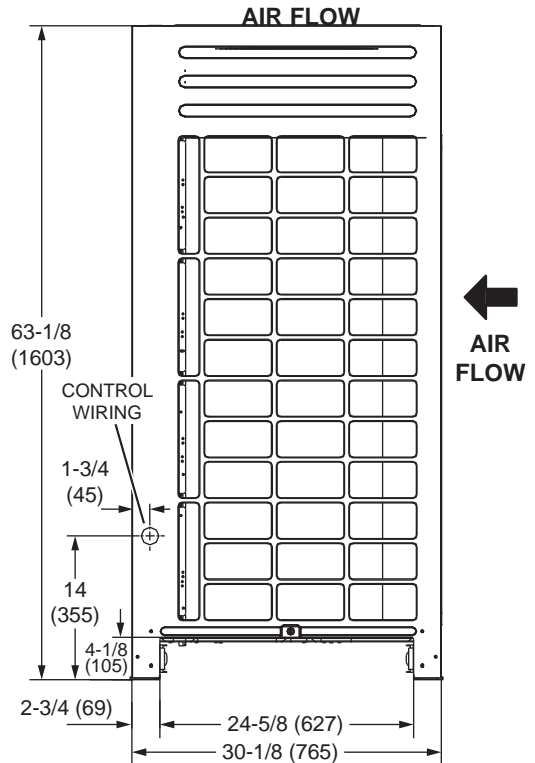

SIDE VIEW

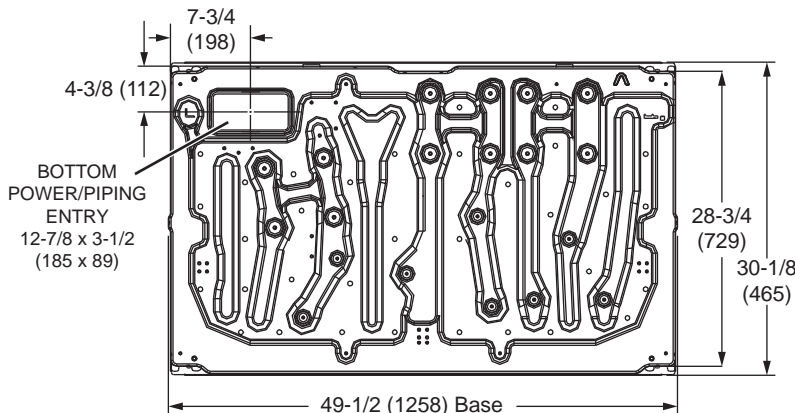

BASE VIEW

DISCLAIMER – Due to Lennox' ongoing commitment to quality, Specifications, Ratings and Dimensions subject to change without notice and without incurring liability. Improper installation, adjustment, alteration, service or maintenance can cause property damage or personal injury. Installation and service must be performed by a qualified installer and servicing agency.