

Job: _____
 Location: _____
 Schedule No.: _____
 System Designation: _____

Engineer: _____
 Architect: _____
 Location: _____
 Date: _____

For: Reference Approval Review Construction

Heat Recovery Outdoor Unit

FEATURES

- Split coil heat exchanger
- Dual hinged electrical boxes for ease of maintenance
- High-efficiency vapor injection inverter compressor
- Intelligent Duty Cycle operation
- Night Silent operation
- Hinged service doors
- Built-in service console
- Built-in base pan heater
- Heating Operation down to -22F
- Low Ambient Cooling down to -10F w/ kit

WARRANTY

- Compressor - 10-year limited warranty
 - All other components - 10-year limited warranty
- *See warranty for details

SPECIFICATIONS

PERFORMANCE

Cooling Capacity ¹ (Btu/h)	Nominal	120,000
	Rated ²	115,000
EER	Ducted	12.3
	Non-Ducted	12.2
IEER	Ducted	23.1
	Non-Ducted	24.1
SCHE	Ducted	30.8
	Non-Ducted	32.8
Heating Capacity ¹ (Btu/h)	Nominal	135,000
	Rated ²	129,000
COP47	Ducted	3.79
	Non-Ducted	3.72
COP17	Ducted	2.44
	Non-Ducted	2.35

ELECTRICAL DATA

Power Supply (Volts/Phase/Hertz)	208-230/3/60
Minimum Circuit Ampacity (A)	82.6
Maximum Overcurrent Protection (A)	90
Compressor RLA (A)	33+33
Number of Compressors	2
Outdoor Fan Power Input (W)	1200+1200

GENERAL DATA

Connection Ratio	50% to 130%
Maximum Number of Indoor Units	22
Refrigerant Type	R-410A
Factory Refrigerant Charge (each unit)	23.8 lbs.

NOTES

1. Cooling and Heating capacity data is rated at the following conditions:
 Cooling: 80°FDB / 67°FWB Indoor, 95°FDB Outdoor
 Heating: 70°FDB Indoor, 47°FDB / 43°FWB Outdoor.
2. Complies with AHRI 1230-2014 testing standards
3. Operating Voltage Range 175V to 263V
4. To achieve cooling lower than 5°F a Low ambient hood must be installed. This is purchased as an accessory.
5. A local 115V power outlet is available as an accessory to provide local power for maintenance.



DIMENSIONS (Each Module)

Unit	Height	72
Dimensions (in)	Width	68-1/2
	Depth	32-5/8

Main System Piping (in)

Liquid Pipe Connection	3/4
Gas Pipe Connection	1-1/4

Balancing Pipework between Modules (in)

L.P. Gas Balance Pipe Connection	1-1/4
H.P. Gas Balance Pipe Connection	3/4
Oil Balance Pipe Connection	5/16
Unit Net Weight (lb)	1093



DIMENSIONAL DRAWINGS - INCHES (MM)

CORNER WEIGHTS								
Model No.	AA		BB		CC		DD	
	lbs.	kg	lbs.	kg	lbs.	kg	lbs.	kg
096, 120L4M-3Y	171	78	262	119	327	148	318	144
096, 120L4M-3G	173	78	266	121	332	151	323	147

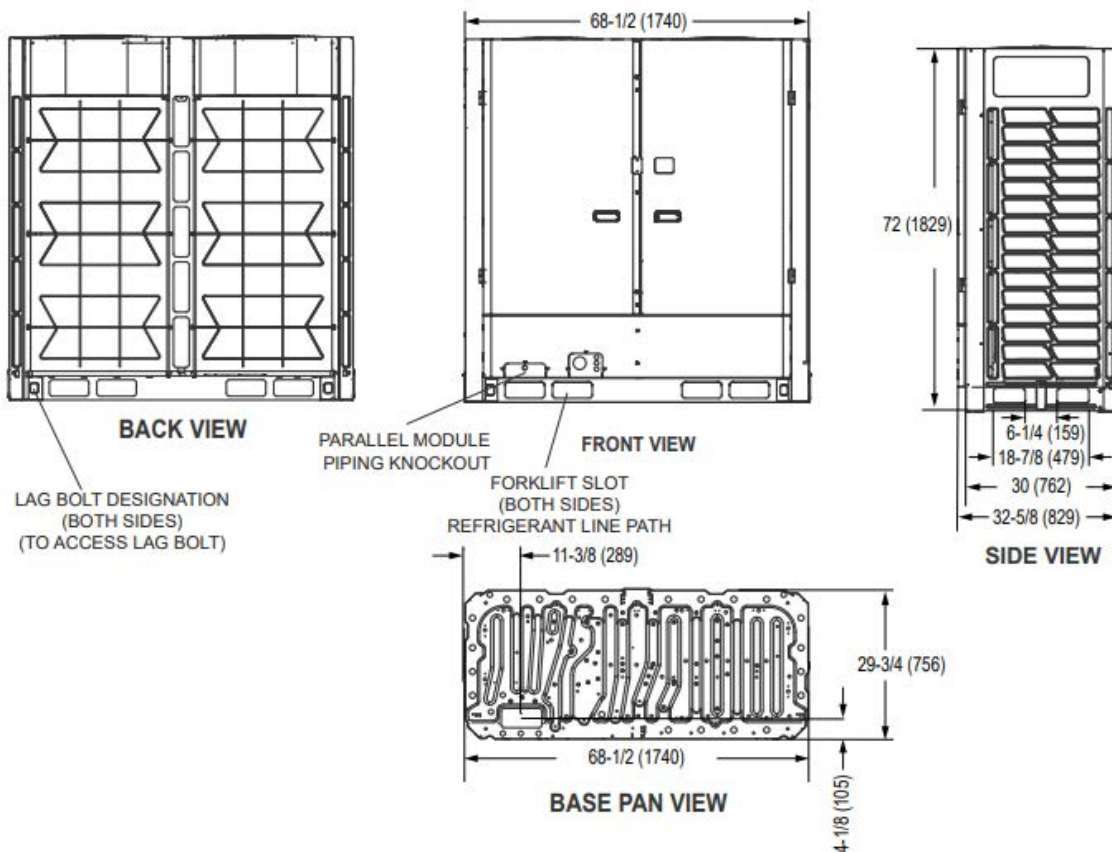
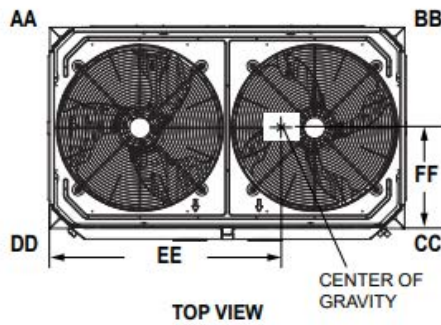

NOTE - Due to Lennox' ongoing commitment to quality, Specifications, Ratings and Dimensions subject to change without notice and without incurring liability. Improper installation, adjustment, alteration, service or maintenance can cause property damage or personal injury. Installation and service must be performed by a qualified installer and servicing agency.