

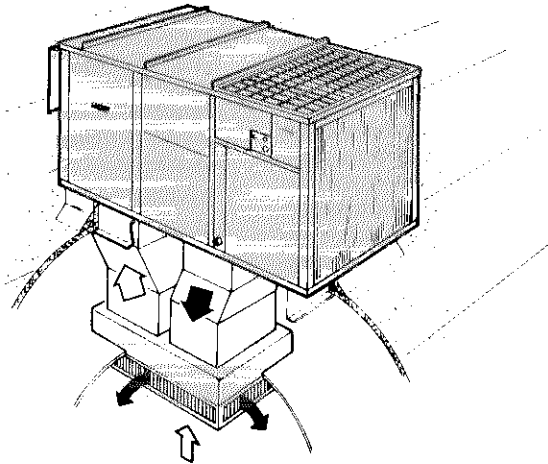

CHA11-2753 AND CHA11-3003
SINGLE PACKAGE AIR CONDITIONERS
*240,000 to 280,000 Btuh Cooling Capacity
71,000 to 307,000 Btuh Optional Electric Heat
*ARI Standard 360 Ratings

ENGINEERING DATA
COOLING UNITS
PACKAGED
Page 31
March 1990
Supersedes March 1988

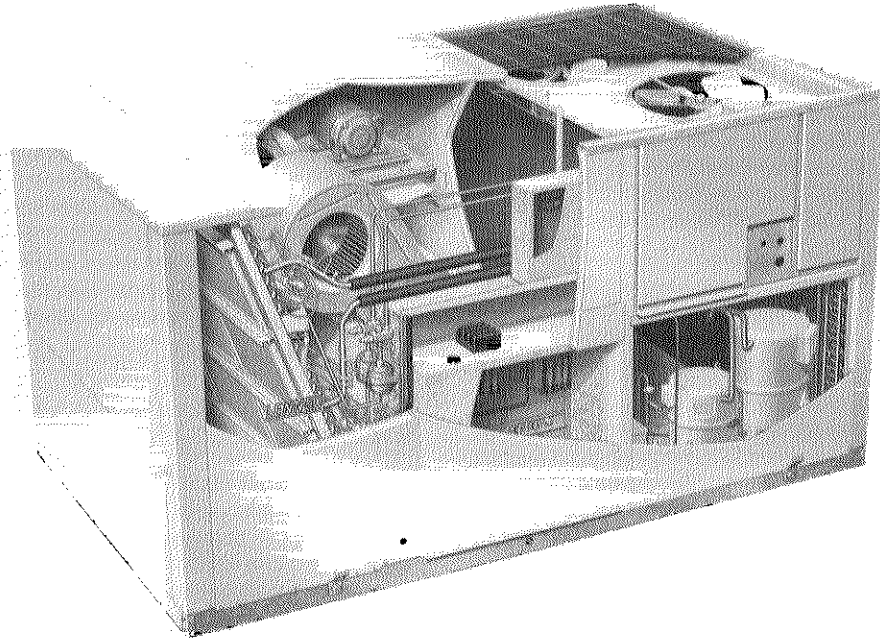

Rooftop Installation with
Combination Ceiling Supply and Return Air System

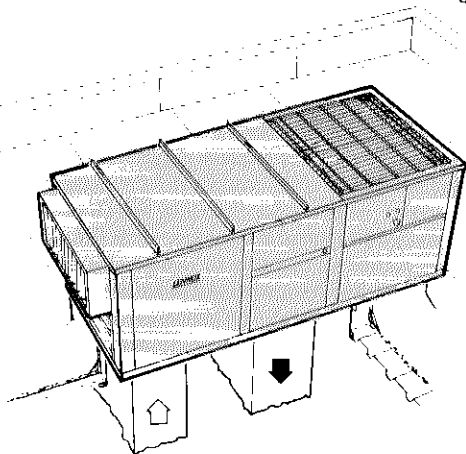

Rooftop Installation with
Double Duct Air Distribution System

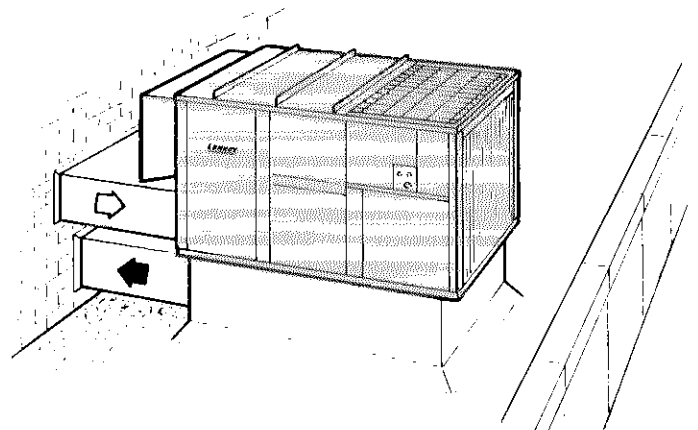

Rooftop Installation with
Horizontal (End) Supply and Return Air System

FEATURES

Applications — The Lennox single package CHA11-2753 and CHA11-3003 units are designed for rooftop installation with bottom handling of supply and return air. A separate roof mounting frame (optional) mates to the bottom of the unit and when flashed into the roof permits weatherproof duct connections and entry into the conditioned area. Separate supply and return air double duct, combination ceiling supply and return air duct, or horizontal end duct systems are applicable to the units. A choice of RTD step-down or FD flush model diffusers are available for combination ceiling supply and return air distribution systems. Economizer dampers option will provide "free cooling" by using outdoor air in lieu of mechanical refrigeration. Units are available with optional electric heat. Thermostat and system controls are not furnished and must be ordered extra. Available as options are W973 control system, W7400 control system, electro-mechanical, Pro-stat or T7300 thermostat control systems. Units are shipped completely factory assembled, piped, and wired. In addition, each unit is test operated at the factory before shipment, insuring unit dependability.

Approvals — Units have been rated in the Lennox Research Laboratory environmental test room in accordance with ARI Standard 360-86. Units are U.L. Listed and components within are bonded for grounding to meet safety standards for servicing required by U. L. and National Electrical Codes. Blower data is from tests conducted in the Lennox Laboratory air test chamber.

Refrigeration System — Factory sealed refrigeration system consists of compressors, condenser coils and direct drive fans, evaporator (dual circuits) coil and blower, expansion valves, sight glasses, high capacity driers, high pressure switches, loss of charge switches, refrigerant lines connected and a full operating charge of refrigerant. Dual independent refrigerant circuits provide staging control to fit varying cooling loads. Lennox augments its reliable operating components with a full complement of standard comfort and safety controls.

Durable Cabinet — Rugged leaktight cabinet is constructed of heavy gauge galvanized steel. Cabinet is subject to a five station metal wash process resulting in a perfect bonding surface for a paint finish of powder enamel, electrostatically bonded to the metal. Base section and cabinet panels exposed to conditioned air are lined with thick fiberglass insulation. Insulation is sandwiched between the panel and a galvanized steel panel liner protecting the insulation indefinitely. Large removable panels allow complete service access. Electrical inlets are provided in the cabinet for wiring entry. Wiring junction box and control boxes with all controls factory installed are conveniently located for service access. Lifting brackets are furnished for ease of handling and rigging. Drainage holes in base rails provide moisture removal. Evaporator coil section drain connections are located on both sides of cabinet.

Dual Compressors — Two compressors in units provide staging control to fit varying cooling load requirements. Reliable compressors are hermetically sealed. Suction cooled, overload protected, and equipped with internal pressure relief valve. Internally protected from excessive current and temperature. Immersible self-regulating type crankcase heater is temperature actuated to operate only when required and ensures proper lubrication at all times. Conveniently located control box gives one spot servicing. The entire running gear is spring mounted within the sealed housing. In addition, the compressors are installed on resilient rubber mounts in the unit, assuring quiet and vibration free operation.

Copper Tube Evaporator and Condenser Coils — Extra large surface area and circuiting of coils provide maximum cooling efficiency, excellent heat transfer and low air resistance. Coils are constructed of precisely spaced ripple-edged aluminum fins fitted to durable copper tubes. Fins are equipped with collars that grip tubing for maximum contact area. Flared shoulder tubing connections and silver soldering provide tight, leakproof joints. Long life copper tubing is easy to field service. Coil is thoroughly factory tested under high pressure to insure leakproof construction. The evaporator coil is face split with two separate circuits. Each circuit has its separate expansion valve, compressor and refrigerant charge.

Efficient Condenser Fans — Two direct drive fans draw large air volumes uniformly through dual condenser coils and discharges it vertically, up and away from the building. Fan orifice design and low fan tip speed keeps operating sound level at a minimum. Uniform air flow through the coils results in high refrigerant cooling capacity. Permanently lubricated, overload protected fan motor is totally enclosed for maximum protection from rain, dust and corrosion. A rain shield on the motor provides additional protection from moisture. Motor is resiliently mounted. Corrosion resistant PVC coated steel wire fan guards are furnished.

Powerful Dual Supply Air Blowers — Twin belt drive centrifugal blowers deliver large air volume efficiently and with minimum power consumption. Blower assembly is mounted to rugged angle iron frame with the entire blower and frame assembly vibration isolated on rubber mounts. Ball bearings are permanently sealed and lubricated. Blower wheel is statically and dynamically balanced. Design of motor mounting base permits quick and simple motor changeover, belt tension adjustment or belt changing. A choice of motor outputs and drives is available. Adjustable motor pulley allows for variable speed adjustments. Motor is overload protected. See specifications table for motors and drives available.

Air Filters — One inch thick frame type throwaway filters are furnished as standard. Fiberglass media is oil impregnated for increased efficiency. Filters are readily accessible for quick and simple replacement. Filter rack is designed to accept two inch thick filters.

Optional Electric Heat — Available factory or field installed in 30 kw through 90 kw sizes. Helix wound nichrome heating elements are exposed directly in the air stream resulting in instant heat transfer, lower coil temperatures and long service life. Elements are accurately located and insulated from the heavy gauge steel support frame by high quality insulators. Time delays bring the elements on and off the line in sequence and equal increments in response to demand with a time delay between each element. Elements are equipped with individual limit controls providing positive protection in case of excessive temperatures. Heaters may be two stage controlled with each stage being energized only when required.

Optional Timed-Off Control — Timed-off control is available for field installation. Prevents compressor short-cycling. Automatic reset control provides a time delay between compressor shut off and start-up. Kit (40G20) includes two controls and must be ordered extra.

Optional Low Ambient Control Kit — System will operate satisfactorily down to 50°F outdoor air temperature without additional controls. If air conditioning operation is required at low ambients a field installed Low Ambient Kit (LB-57113BB) can be added enabling the unit to operate down to 0°F.

Optional REMD11M-275 Economizer Dampers — Available factory or field installed. Lennox economizer system consists of: mechanically linked outdoor air and recirculated air dampers. Damper blades are gasketed for tight seal and quiet operation. Formed damper blades rotate smoothly in nylon bearings. The positioning of these dampers is accomplished by a 24 volt fully modulating spring return damper motor with adjustable minimum position switch and controlled by the room thermostat, electronic discharge air sensor and solid-state adjustable outdoor air enthalpy control. An outdoor air hood with rain eliminator vanes is furnished and field installs over the outdoor air dampers external to the unit. For field installation the two damper sections slide in cavities provided in the unit cabinet. Economizer is shipped factory wired and only requires plug-in field connection. The enthalpy control allows for 0 to 100% outdoor air (first stage of cooling) to be used for "free cooling" when outdoor humidity and temperature are acceptable. Additionally, an integrated economizer cycle can be accomplished by allowing the outside air dampers to remain open, continuing to admit outside air, and cycling the compressors to provide dehumidification and additional cooling as needed. The integrated economizer cycle uses only the amount of mechanical cooling necessary.

FEATURES

Optional Differential Enthalpy Control — A solid-state return air enthalpy sensor is available to be used in conjunction with the outdoor air enthalpy control to determine which air has the lowest enthalpy. The air with the lowest enthalpy will be selected. Return air enthalpy sensor (54G44) field installs in the economizer damper section and must be ordered extra.

Optional GED11-275 Gravity Exhaust Air Dampers — Dampers field install in space provided in the unit. Pressure operated extruded aluminum dampers rotate smoothly in nylon bearings. Damper blades are equipped with gaskets for tight seal and quiet operation.

Optional PED11-275 Power Exhaust Dampers — Field installs in space provided in the unit cabinet. Fans provide system pressure relief and are interlocked to run when return air dampers are closed and supply air blowers are operating. Motors are overload protected. Pressure operated extruded aluminum dampers ride in nylon bearings and are equipped with seal gaskets resulting in tight seal and quiet operation. Dampers prevent blow-back and outdoor air infiltration during off cycle.

Optional OAD11-275 Minimum Fresh Air Dampers — Damper section complete with cleanable polyurethane air filter field installs external to the unit cabinet. Available for manual or automatic operation. Damper assembly allows a fixed amount of outdoor air into the system and can be adjusted for air quantities up to 25%. Automatic damper operation is available with the addition of a spring return 3 position damper actuator. Actuator only requires plug-in connection for operation. Order Automatic Fresh Air Damper Kit 88G13.

Optional RMF11-275 Standard Roof Mounting Frame — Sturdy mounting frame mates to the single package unit and provides an automatic weather sealed rooftop installation. Shipped knocked down for ease of shipping and handling it is easily field assembled. A nailer strip is secured to the frame sides to facilitate flashing. Approved by National Roofing Contractors Association.

Optional RMFH11-275 Horizontal Roof Mounting Frame — Frame mates to CHA11 unit and provides horizontal end supply and return air (over/under) duct connection. Supply air connection is in end of frame. Return air connection is made at evaporator section end of unit. Shipped knocked down for ease of shipping and handling; it is easily field assembled. See dimension drawing.

Optional RMFA11-275 Adapter Roof Mounting Frame — Retrofit adapter frame is available for CHA11 model replacement of existing CHA8 unit installation. The frame adapts to the existing RMF3 frame and provides a weather sealed connection with minimum installation cost. Frame is shipped knocked down for ease of shipping and handling, it is easily field assembled. A nailer strip is secured to the frame sides to facilitate flashing. See dimension drawing and installation detail sketch.

Optional RTD11-275 Combination Ceiling Supply and Return Diffuser Assembly — Step down mount diffuser extends slightly below ceiling level and discharges conditioned air out through grilles on all four sides. Aluminum grilles are fitted with double deflection louvers for precise directional control of air flow. Return air enters through the large center grille. Assembly also includes insulated diffuser box with flanges for ease of duct connection, hanging rings for suspending and interior transition to insure low static and even air flow on all four sides. Transition is sealed internally to prevent recirculation. Diffuser assembly is completely factory assembled. Diffuser readily adapts to T-bar ceiling grids and plaster ceilings.

Optional FD11-275 Combination Ceiling Supply and Return Diffuser Assembly — Flush mount diffuser installs almost flush with the ceiling level and discharges conditioned air out through fixed blade louvers on all four sides. Fixed blade louvers insure that air flow will be evenly distributed. Return air enters through large center grille. Assembly also includes insulated diffuser box with flanges for ease of duct connections, support hanger eyelets at the top corners for secure installation and interior transition to insure low static and even air flow on all four sides. Transition is sealed internally to prevent recirculation. Diffuser assembly is completely factory assembled. Diffuser readily adapts to T-bar ceiling grids and plaster ceilings.

Optional SRT11-275 Supply and Return Transitions — Transitions field install in the RMF11-275 roof mounting frame and provide segregated and simple duct connections to supply and return diffuser. Completely insulated galvanized steel transitions have flanges for ease of duct connection. Duct from the transitions to the diffuser is not furnished and must be provided by installer. Transitions are completely factory assembled and easily field installed in the roof mounting frame with minimum costs and labor requirements.

Optional SP11 Remote Status Panel — The operation of the unit can be checked at a glance on the Remote Status Panel (12F83) conveniently located within the conditioned area. Signal lights on the panel indicate "Cool Mode", "Heat Mode", "Compressor 1", "Compressor 2", "No Heat" and "Filter". The Cool Mode signal light is green when lit and indicates economizer damper operation or DX cooling operation for units without the economizer. Heat Mode light is green and reflects heating operation. Compressor 1 and Compressor 2 lights are green when operating and will turn red if there is an operational malfunction. The No Heat and Filter lights will show red and indicate a requirement for service. The following field installed controls are required for use with the status panel and must be ordered extra. Filter Switch Kit (97C85) is required for operation of the filter light. Status Panel Readout Relay Kit (88G28) is required to interface status panel with unit operation.

Optional SSP11 Remote Switching Status Panel — The operation of the unit can be controlled and observed on the Switching Status Panel (12F84) conveniently located within the conditioned area. Signal lights on the panel indicate "Cool Mode", "Heat Mode", "Compressor 1", "Compressor 2", "No Heat" and "Filter". The Cool Mode signal light is green when lit and indicates economizer damper operation or DX cooling operation for units without the economizer. Heat Mode light is green and reflects heating operation. Compressor 1 and Compressor 2 lights are green when operating and will turn red if there is an operational malfunction. The No Heat and Filter lights will show red and indicate a requirement for service. Additionally, panel is equipped with a system selector switch (Off — Heat — Auto — Cool — Emergency Heat) (Heat Pump Only), fan switch (Auto — On) and after hours timer. Fan switch provides a choice of intermittent (Auto) or continuous (On) blower operation. Manually operated after hours timer (0 to 12 hours) overrides night setback controls providing normal operation for time period set. A momentary push button switch is used to initiate the timer period. The following field installed controls are required for use with the status panel and must be ordered extra. Filter Switch Kit (97C85) is required for operation of the filter light. Status Panel Readout Relay Kit (88G28) is required to interface status panel with unit operation.

CONTROL SYSTEM OPTIONS

Optional Electro-Mechanical Thermostat and Control System — The thermostat and related controls of this system must be ordered extra for field installation. Two stage heat and two stage cool thermostat (13F06) with dual temperature selector levers. Uses subbase (13F17) with manual system switch (Off-Heat-Auto-Cool) and fan switch (Auto-On) or non-switching subbase (13F16). SP11 Remote Status Panel (12F83) or SSP11 Remote Switching Status Panel (12F84) is available for observing and controlling unit operation from the conditioned area. A SSP11 Relay Kit (41G39) is required for switching functions of the Switching Status Panel. Kit must be ordered extra and field installed. For nite operation the following are available. Single stage heating thermostat (13F12) and non-switching subbase (13F16). For applications without the economizer a Nite Kit (39G74), containing a plug-in relay, is required to override the operation of day thermostat. Two time clocks are available for the system. Automatic 7 day time clock (43G98) programs a weekly schedule. Any day or days can be omitted. Each day of the week is clearly separated from every other day. Day and nite periods are distinctly marked. When the settings have been made the clock will turn the system on and off. Spaced in 2 hour increments and equipped with battery back-up in case of power outage. 24 hour nite setback time clock (43G99) automatically programs the system to keep conditioned area at a more conservative temperature level (nite setback thermostat setting) during a period of vacancy. Spaced in 15 minute increments and equipped with battery back-up in case of power outage. Also available is a Warm Up Kit (39G77) which holds the economizer outdoor air dampers closed during nite heat operation and morning warm up. See Flow Chart on page 36.

Optional PRO-STAT Thermostat and Control System — The thermostat and related controls of this system must be ordered extra and field installed. Pro-stat Thermostat (36G67) has touch sensitive keyboard, automatic switching from heat to cool, no anticipator, zero droop, indicator lights, hour/day programming, override capabilities, time readout, stage status indicators, operational mode symbols and battery back-up. A Remote Temperature Sensor (36G68) can be adapted to thermostat for applications where it is desirable to locate the thermostat out of the conditioned area. SP11 Remote Status Panel (12F83) is available for checking unit operation from within the conditioned area. Also available is a Warm Up Kit (39G77) which holds the economizer outside air dampers closed during nite heat operation and morning warm up. See Flow Chart on page 36.

Optional W973 Control System — Control system must be ordered extra for field installation. Logic Panel (39G76) controls the operation of the economizer dampers and the stages of cooling and heating in response to a signal from the thermostat. To maintain stable temperatures the logic panel balances the conditioned space thermostat demand against the system output. System output is measured by a discharge sensor (furnished with the logic panel) located in the discharge air duct of the unit. The combined demand and output signals from the sensor determines economizer damper position and number of cooling or heating stages energized. The logic panel field installs in the unit or in a remote panel located within the conditioned space. W973 Plug-In Relay (furnished with the logic panel) is required to adapt the control system to the unit. Two thermostats are available for the system. Dual set point room thermostat (25C52) or transmitter (25C51) with a choice of remote sensors. Both have separate heating-cooling locking set points concealed under the cover and do not have indicating thermometer. The room thermostat has integral sensor and installs in the conditioned space. The transmitter installs outside the conditioned space with a Room Temperature Sensor (58C92) in the conditioned area or a Return Air Temperature Sensor (27C40) in the return air duct of the unit. Thermostat and transmitter are furnished with a wiring wallplate. Also available is switching subbase (58C93) with system selector switch (Heat-Auto-Cool-

Off) and fan switch (Auto-On). SP11 Remote Status Panel (12F83) or SSP11 Remote Switching Status Panel (12F84) is available for observing and controlling unit operation from the conditioned area. Two time clocks are available for the system. Automatic 7 day time clock (43G98) programs a weekly schedule. Any day or days can be omitted. Each day of the week is clearly separated from every other day. Day and nite periods are distinctly marked. When the settings have been made the clock will turn the system on and off. Spaced in 2 hour increments and equipped with battery back-up in case of power outage. 24 hour nite setback time clock (43G99) automatically programs the system to keep the conditioned area at a more conservative temperature level (nite set back thermostat setting) during a period of vacancy. Spaced in 15 minute increments and equipped with battery back-up in case of power outage. Also available is a Warm Up Kit (39G77) which holds the economizer outdoor air dampers closed during nite heat operation and warm up. See Flow Chart on page 35.

Optional W7400 Control System — Control system must be ordered extra for field installation. Control Module (74G11) controls the operation of the economizer dampers and the stages of heating and cooling. Controlling input signals are setpoint, space temperature sensor and time-of-day scheduling from the thermostat. The control module balances the space temperature signal against the number of stages operating for system output. System output is measured and updated by monitoring the actual space temperature deviation from set point, and the rate of change of the space temperature. The control module field installs in the unit or in a remote panel located within the conditioned area. Two thermostats are available for the system. A room thermostat (36G62) with integral sensor that installs in the conditioned space or a remote thermostat (36G64) that installs outside the conditioned space with a Room Temperature Sensor (58C92) in the conditioned area or a Return Air Temperature Sensor (27C40) in the return air duct of the unit. Both thermostats are equipped with touch sensitive keyboard, automatic switching from heat to cool, no anticipator, zero droop, indicator lights, hour/day programming, override capabilities, time readout, stage status indicators, battery back-up and wiring wallplate. W7400 Plug-In Relay (furnished with the control module) provides separate set points for the economizer dampers and DX cooling. SP11 Remote Status Panel (12F83) is available for checking unit operation within the conditioned area. See Flow Chart on page 36.

Optional T7300 Thermostat and Control System — The thermostat and related controls of this system must be ordered extra for field installation. T7300 programmable thermostat (81G59) has internal or optional remote temperature sensing, touch sensitive keyboard, automatic switching from heat to cool, °F or °C temperature readout, no anticipator, droop/no droop selection, indicator LED's, hour/day programming, override capabilities, time readout, stage status indicators, operational mode readout and battery back-up. T7300 thermostat has a choice of subbases. Switching subbase (81G60) features selectable output staging up to two heat and two cool, indicator LED's, manual system switch (Heat-Off-Auto-Cool) and fan switch (Auto-On). Switching subbase (13H76) features selectable output staging up to three heat and two cool, indicator LED's, manual system switch (Auto-Cool-Off-Heat-Emergency Heat) (Heat Pump Only) and fan switch (Auto-On). Both subbases also feature an auxiliary relay output which controls economizer operation during occupied and unoccupied periods. Also available is a Room Temperature Sensor (58C92) or Room Temperature Sensor with 3-hour override and setpoint adjustment (86G67) for installation in the conditioned area and a Return Air Temperature Sensor (27C40) for installation in the return air duct of the unit. SP11 Status Panel (12F83) is available for checking unit operation from within the conditioned area. See Flow Chart on page 35.

TEMPERATURE CONTROL SELECTION FLOW CHART

OPTIONAL W973 CONTROL SYSTEM

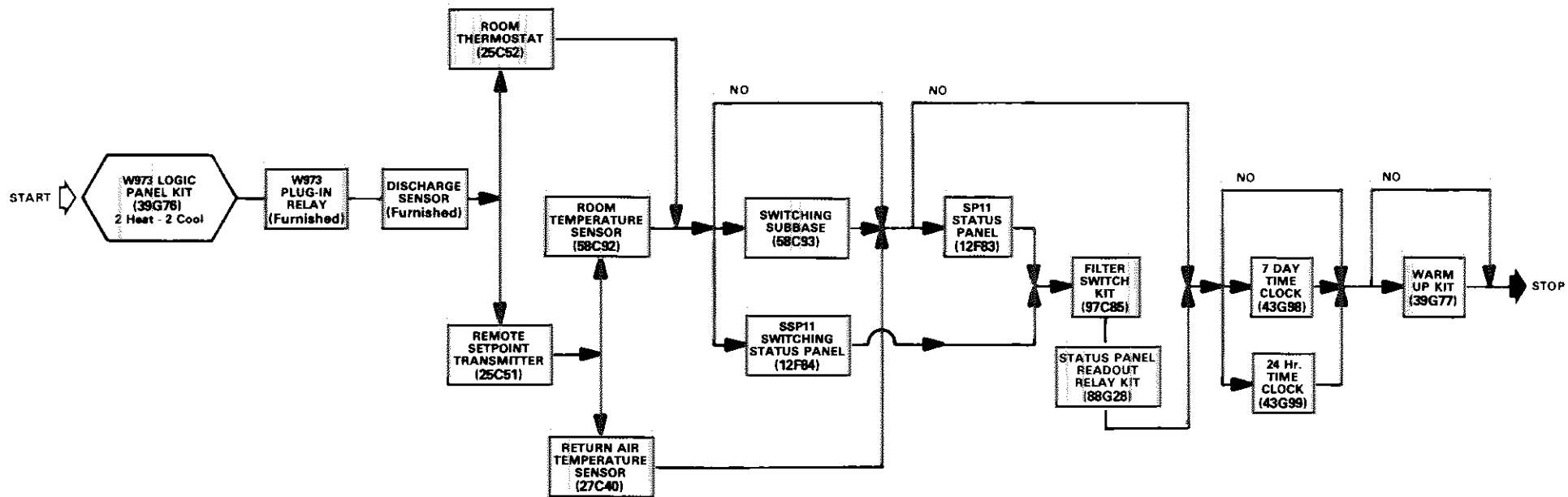

OPTIONAL T7300 THERMOSTAT CONTROL SYSTEM

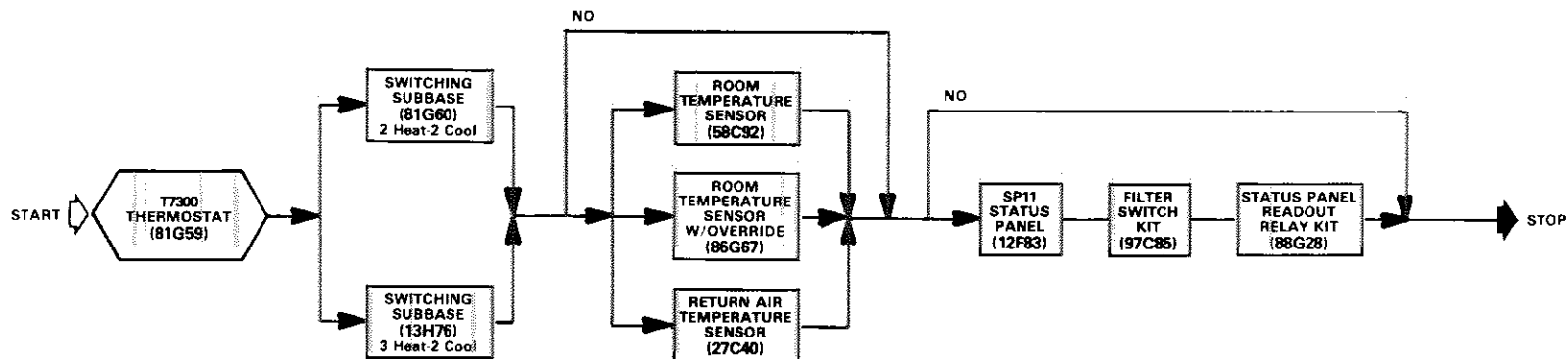

TEMPERATURE CONTROL SELECTION FLOW CHART

OPTIONAL ELECTRO-MECHANICAL THERMOSTAT CONTROL SYSTEM

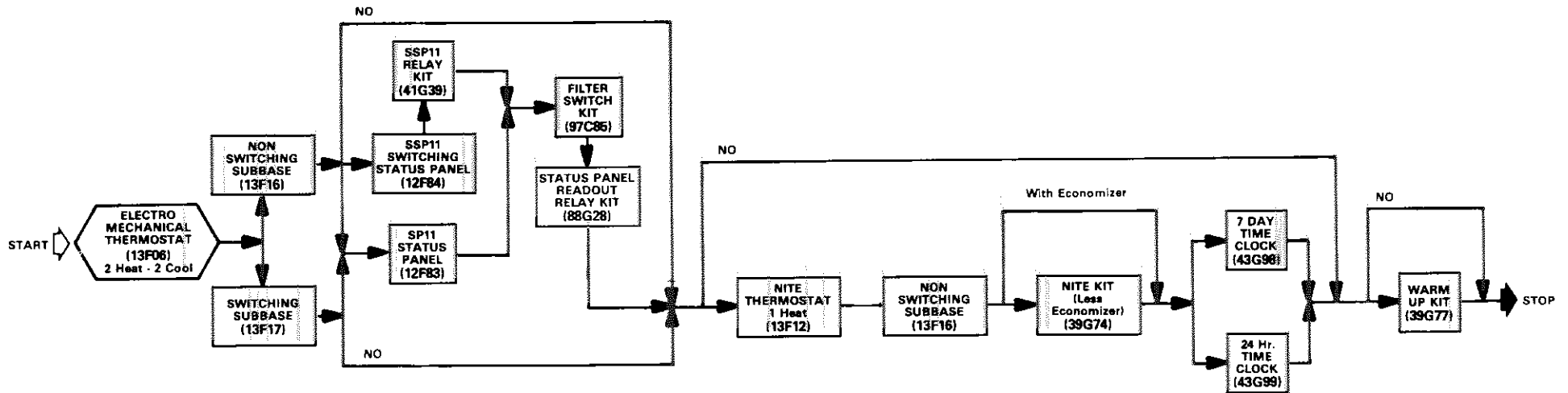

OPTIONAL W7400 CONTROL SYSTEM

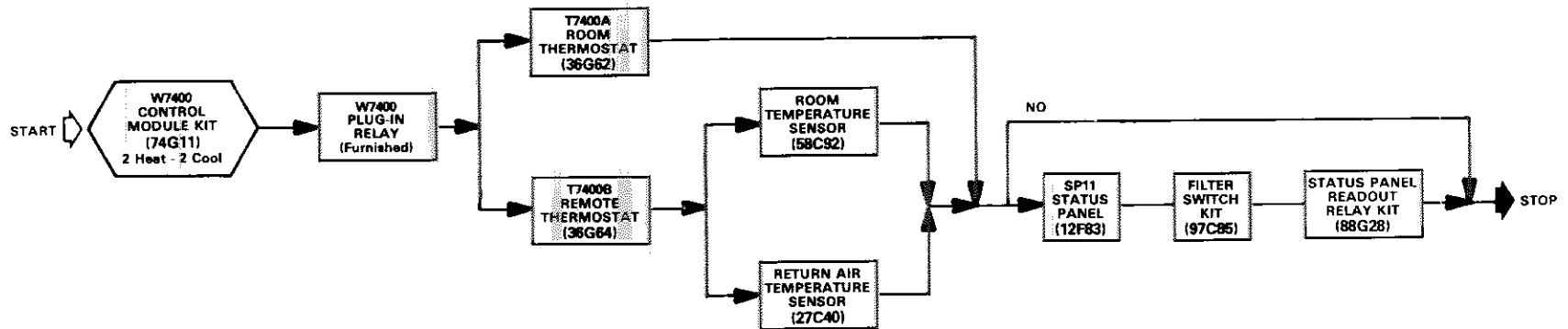

OPTIONAL PRO-STAT THERMOSTAT CONTROL SYSTEM

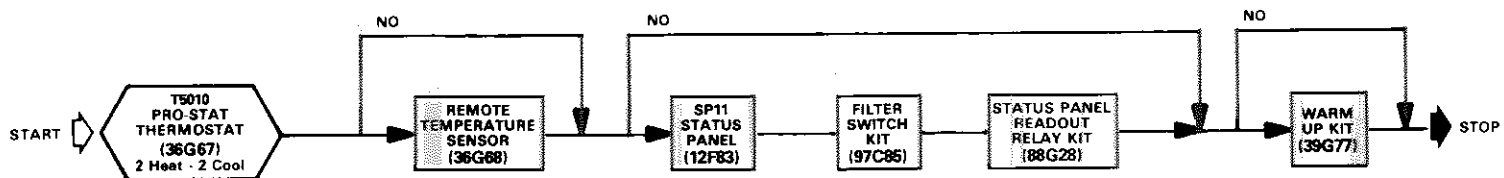

SPECIFICATIONS

Model Number			CHA11-2753	CHA11-3003
*ARI Standard 360 Ratings	Total cooling capacity (Btuh)		240,000	★ 280,000
	Total unit watts		28,800	35,600
	EER (Btuh/Watts)		8.30	7.90
	Integrated Part Load Value		8.3	7.9
Refrigerant (22) charge			Stage 1	19 lbs. 0 oz.
			Stage 2	20 lbs. 8 oz.
Evaporator Blower and Drive Selection	Blower wheel nominal diameter x width (in.)		(2) 15 x 15	(2) 15 x 15
	Factory Installed †Drives	Nominal motor horsepower	5	10
		Maximum usable horsepower	5.75	11.50
		Voltage & Phase	200/230/460v-3ph	460v-3ph
		RPM range	790 – 965 (††600 – 760)	940 – 1115
	Optional Factory Installed †Drives	Nominal motor horsepower	7-1/2	----
		Maximum usable horsepower	8.63	----
		Voltage & Phase	200/230/460v-3ph	----
RPM Range		940 – 1090	----	
Evaporator Coil	Net face area (sq. ft.)		23.5	23.5
	Tube diameter (in.) & No. of rows		1/2 – 3	1/2 – 4
	Fins per inch		15	15
Condenser Coil	Net face area (sq. ft.)		38.9	38.9
	Tube diameter (in.) & No. of rows		3/8 – 4	3/8 – 4
	Fins per inch		20	20
Condenser Fans	Diameter (in.) & No. of blades		(2) 26 – 5	(2) 26 – 5
	Air volume (cfm)		(2) 6700	(2) 6700
	Motor horsepower		(2) 1	(2) 1
	Motor watts		(2) 1050	(2) 1050
Condensate drain size mpt (in.)			(2) 1-1/4	(2) 1-1/4
No. & size of filters (in.)			(11) 16 x 20 x 1	(11) 16 x 20 x 1
Net weight of basic unit (lbs.) (1 Package)			2900	2950
Electrical characteristics			200 to 460 volt – 60 hertz – 3 phase	460 volt – 60 hertz – 3 phase
Optional Electric Heat	Model No.		ECH11-275	
	kw input range		30-45-60-75-90	
Optional Roof Mounting Frame – (Net weight)			Standard	RMF11-275 (315 lbs.)
			Horizontal	RMFH11-275 (440 lbs.)
			Adapter	RMFA11-275 (510 lbs.)
Optional Economizer & Controls – (Net weight)			REMD11M-275 (290 lbs.)	
Optional Gravity Exhaust Dampers – (Net weight)			GED11-275 (30 lbs.)	
Optional Power Exhaust Dampers	Model No. – (Net weight)		PED11-275 (150 lbs.)	
	Exhaust Fans	Diameter (in.) & No. of blades	(3) 18 – 5	
		Total air volume (cfm)	7050	
		Motor horsepower	(3) 1/4	
		Watts input (total)	1100	
Optional Ceiling Supply and Return Air Diffusers (Net weight)			Step-down	RTD11-275 (403 lbs.)
			Flush	FD11-275 (363 lbs.)
			Transition	SRT11-275 (80 lbs.)
Optional Fresh Air Damper & Filter Size (in.) – (Net weight)			OAD11-275 (115 lbs.) 1 – 26 x 31 x 1	
Optional Automatic OAD11 Damper Kit – (Net weight)			88G13 (15 lbs.)	

*Rated in accordance with ARI Standard 360; 95°F outdoor air temperature and 80°F db/67°F wb entering evaporator air; minimum external duct static pressure.

★ Rated at ARI Standard 360 test conditions.

†Using total air volume and system static pressure requirements determine from blower performance tables rpm and bhp required. Maximum usable hp of motors furnished by Lennox are shown. If motors of comparable hp are used be sure to keep within the service factor limitations outlined on the motor nameplate.

††Motor pulley furnished with unit for field installation, if required.

ELECTRICAL DATA

Model No.		CHA11-2753				CHA11-3003		
Line voltage data — 60 Hz — 3 phase		200V		230V		460V		460V
Compressors (2)	Rated load amps (total)	39.5/39.5 (79.0)		39.5/39.5 (79.0)		20.4/20.4 (40.8)		25.1/25.1 (50.2)
	Locked rotor amps (total)	229/229 (458.0)		229/229 (458.0)		116/116 (232.0)		110/110 (220.0)
Outdoor Coil Fan Motors (2)	Full load amps (total)	12.8		10.4		5.6		5.6
	Locked rotor amps (total)	30		28		13.2		13.2
Indoor Coil Blower Motor	Horsepower	5	7-1/2	5	7-1/2	5	7-1/2	10
	Full load amps	17.5	25.3	15.2	22.0	7.6	11	14.0
	Locked rotor amps	100.0	160.0	90.0	127.0	45.0	64.0	79.0
Optional Exhaust Fan Motors	(No.) Horsepower	(3) — 1/4		(3) — 1/4		(3) — 1/4		(3) — 1/4
	Full load amps (total)	4.2		4.2		2.2		2.2
	Locked rotor amps (total)	9.8		9.8		4.9		4.9
Recom. max. fuse size (amps)	Less Exhaust Fans	150	150	150	150	70	70	100
	With Exhaust Fans	150	150	150	150	70	70	100
Unit Power Factor	Less Exhaust Fans	.88	.87	.88	.87	.88	.87	.84
	With Exhaust Fans	.88	.87	.88	.87	.88	.87	.85
*Minimum Circuit Ampacity	Less Exhaust Fans	120.0	127.0	115.0	122.0	60.0	63.0	79.0
	With Exhaust Fans	124.0	132.0	119.0	126.0	62.0	65.0	81.0

*Refer to National Electrical Code manual to determine wire, fuse and disconnect size requirements.

NOTE - Extremes of operating range are plus and minus 10% of line voltage.

CHA11-2753 OPTIONAL ELECTRIC HEAT DATA

Electric Heat Model No. & Net Weight	No. of Steps	Volts Input	kw Input	Btuh Output	Total Unit & Electric Heat	
					*Minimum Circuit Ampacity	
					5 hp	7-1/2 hp
ECH11-275-30 (135 lbs.)	2	200	20.8	71,000	124	132
		210	23.0	78,500		
		220	25.2	86,000		
		230	27.5	93,900		
	1	240	30.0	102,400	119	126
		440	25.2	86,000		
ECH11-275-45 (145 lbs.)	3	460	27.5	93,900	62	65
		480	30.0	102,400		
		200	31.3	106,800		
		210	34.5	117,700		
		220	37.8	129,000		
	2	230	41.3	141,000	137	147
		240	45.0	153,600		
		440	37.8	129,000		
		460	41.3	141,000		
		480	45.0	153,600		
ECH11-275-60 (145 lbs.)	4	200	41.7	142,300	176	185
		210	46.0	157,000		
		220	50.4	172,000		
		230	55.1	188,100		
		240	60.0	204,800		
	2	440	50.4	172,000	198	206
		460	55.1	188,100		
		480	60.0	204,800		
		200	52.1	177,700		
		210	57.4	196,000		
ECH11-275-75 (155 lbs.)	5	220	63.0	215,000	217	227
		230	68.9	235,000		
		240	75.0	255,900		
		440	63.0	215,000		
		460	68.9	235,000		
	3	480	75.0	255,900	243	251
		200	62.5	213,300		
		210	68.9	235,000		
		220	75.6	258,000		
		230	82.7	282,000		
ECH11-275-90 (155 lbs.)	6	240	90.0	307,100	256	265
		440	75.6	258,000		
		460	82.7	282,000		
	3	480	90.0	307,100	287	295
		200	62.5	213,300		
		210	68.9	235,000		

*Refer to National Electrical Code manual to determine wire, fuse and disconnect size requirements. Use wires suitable for at least 167°F.
NOTE - May be used with two stage control.

CHA11-3003 OPTIONAL ELECTRIC HEAT DATA

Electric Heat Model No. & Net Weight	No. of Steps	Volts Input	Kw Input	Btuh Output	Total Unit & Electric Heat	
					*Minimum Circuit Ampacity	
					10 hp	
ECH11-275-30 (135 lbs.)	1	440	25.2	86,000	79	
		460	27.5	93,900		
		480	30.0	102,400		
ECH11-275-45 (145 lbs.)	2	440	37.8	129,000	83	
		460	41.3	141,000		
		480	45.0	153,600		
ECH11-275-60 (145 lbs.)	2	440	50.4	172,000	104	
		460	55.1	188,100		
		480	60.0	204,800		
ECH11-275-75 (155 lbs.)	3	440	63.0	215,000	126	
		460	68.9	235,000		
		480	75.0	255,900		
ECH11-275-90 (155 lbs.)	3	440	75.6	258,000	148	
		460	82.7	282,000		
		480	90.0	307,100		

*Refer to National Electrical Code manual to determine wire, fuse and disconnect size requirements. Use wires suitable for at least 167°F.
NOTE - May be used with two stage control.

FIELD WIRING W7400 CONTROL SYSTEM

- A -- Three wire power (See Electrical Data Table)
- B -- Two wire low voltage
- C -- Four wire low voltage
- D -- Nine wire low voltage

- Field wiring not furnished -

NOTE -- All wiring must conform to NEC and local electrical codes.

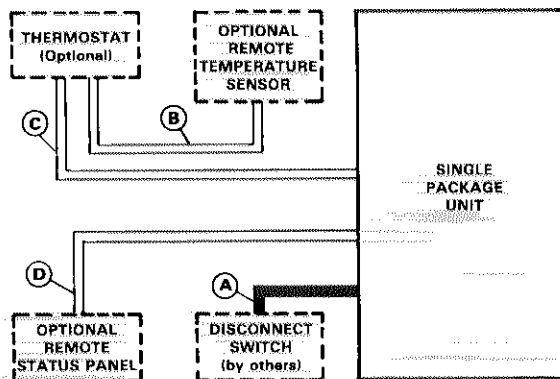

PRO-STAT OR T7300 THERMOSTAT CONTROL SYSTEM

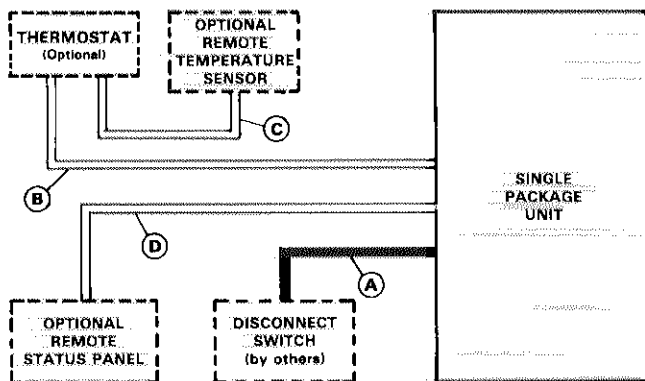

- A -- Three wire power (See Electrical Data Table)
- B -- Seven wire low voltage (Pro-Stat)
-- Nine wire low voltage (T7300)
- C -- Two wire low voltage
- D -- Nine wire low voltage

- Field wiring not furnished -

NOTE -- All wiring must conform to NEC and local electrical codes.

W973 CONTROL SYSTEM

- A -- Three wire power (See Electrical Data Table)
- B -- Seven wire low voltage -- DC only
- Five wire low voltage -- DC only -- with SSP11 Switching Status Panel
- Seven wire low voltage -- DC only -- with switching subbase
- C -- Two wire low voltage -- AC only -- with switching subbase
- D -- Two wire low voltage -- DC only
- E -- Nine wire low voltage -- AC only
- F -- Two wire low voltage -- AC only
- G -- Two wire low voltage -- AC only
- H -- Thirteen wire low voltage -- AC only
- J -- Two wire low voltage -- DC only

AC -- Alternating current
DC -- Direct current

NOTE -- Run separate harnesses for AC and DC.
AC voltage interferes with DC signals.

- Field wiring not furnished -

NOTE -- All wiring must conform to NEC and local electrical codes.

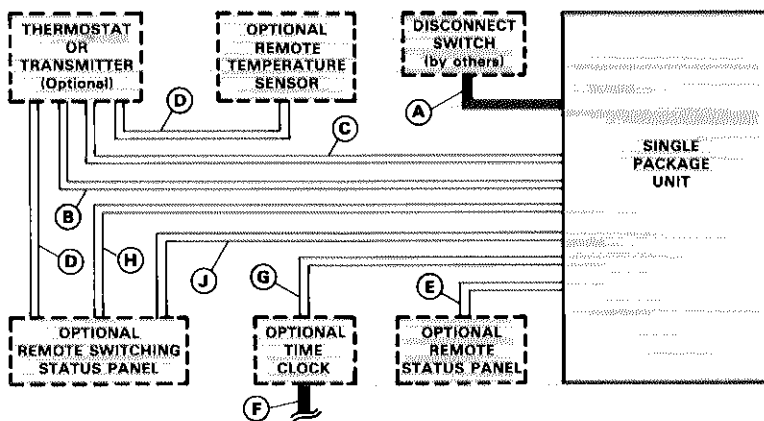

ELECTRO-MECHANICAL THERMOSTAT CONTROL SYSTEM

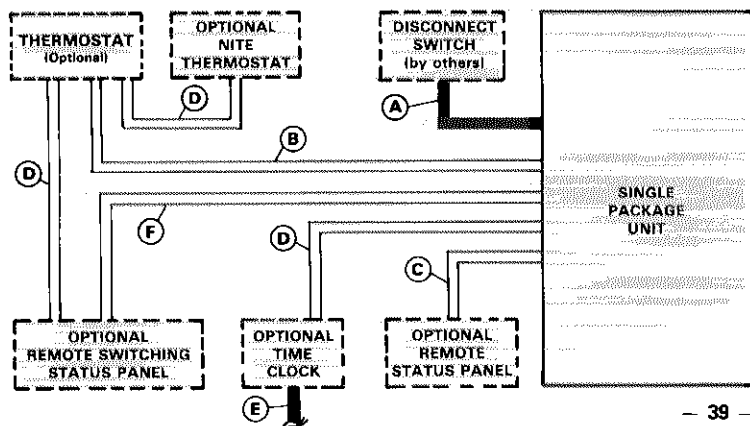

- A -- Three wire power (See Electrical Data Table)
- B -- Six wire low voltage
-- Five wire low voltage - with SSP11 Switching Status Panel
- C -- Nine wire low voltage
- D -- Two wire low voltage
- E -- Two wire low voltage
- F -- Fifteen wire low voltage

- Field wiring not furnished -

NOTE -- All wiring must conform to NEC and local electrical codes.

RATINGS

NOTE To determine sensible capacity, leaving wet bulb and dry bulb temperatures not shown in the cooling tables, see Miscellaneous Engineering Data section, Page 9.

CHA11-2753 COOLING CAPACITY (With One Compressor Only Operating)

Enter. Wet Bulb (°F)	Total Air Vol. (cfm)	Outdoor Air Temperature Entering Condenser Coil (°F)																			
		65			75			85			95										
		Total Cool Cap. (Btuh)	Comp. Motor Watts Input	Sensible To Total Ratio (S/T) Dry Bulb (°F)	Total Cool Cap. (Btuh)	Comp. Motor Watts Input	Sensible To Total Ratio (S/T) Dry Bulb (°F)	Total Cool Cap. (Btuh)	Comp. Motor Watts Input	Sensible To Total Ratio (S/T) Dry Bulb (°F)	Total Cool Cap. (Btuh)	Comp. Motor Watts Input	Sensible To Total Ratio (S/T) Dry Bulb (°F)								
														76	80	84	76	80	84	76	80
63	7000	130,700	9060	.72	.82	.92	125,800	9890	.73	.84	.94	120,400	10,680	.75	.85	.96	115,100	11,400	.76	.87	.98
	8500	135,300	9240	.76	.87	.98	130,100	10,070	.77	.89	1.00	124,500	10,860	.78	.91	1.00	118,700	11,590	.80	.93	1.00
	10,000	139,400	9390	.79	.92	1.00	133,900	10,220	.81	.94	1.00	128,100	11,020	.83	.96	1.00	122,200	11,750	.85	.99	1.00
67	7000	141,500	9460	.57	.67	.76	136,000	10,300	.58	.68	.78	130,000	11,100	.59	.69	.79	123,900	11,830	.60	.70	.81
	8500	146,000	9620	.59	.70	.80	139,900	10,470	.60	.71	.82	133,600	11,260	.61	.73	.84	127,100	11,980	.62	.74	.86
	10,000	149,600	9750	.62	.73	.85	143,200	10,600	.62	.75	.87	136,500	11,390	.64	.77	.89	129,700	12,100	.65	.79	.92
71	7000	152,500	9860	.44	.53	.62	146,300	10,720	.45	.54	.63	139,700	11,520	.45	.54	.64	133,000	12,250	.45	.55	.65
	8500	156,900	10,010	.45	.55	.65	150,200	10,870	.45	.56	.66	143,300	11,670	.46	.57	.67	136,200	12,390	.46	.58	.69
	10,000	160,400	10,140	.46	.57	.68	153,500	10,990	.46	.58	.69	146,200	11,790	.47	.59	.71	138,800	12,510	.48	.60	.73

CHA11-2753 TOTAL COOLING CAPACITY (With Both Compressors Operating)

Enter. Wet Bulb (°F)	Total Air Vol. (cfm)	Outdoor Air Temperature Entering Condenser Coil (°F)																			
		85			95			105			115										
		Total Cool Cap. (Btuh)	Comp. Motor Watts Input	Sensible To Total Ratio (S/T) Dry Bulb (°F)	Total Cool Cap. (Btuh)	Comp. Motor Watts Input	Sensible To Total Ratio (S/T) Dry Bulb (°F)	Total Cool Cap. (Btuh)	Comp. Motor Watts Input	Sensible To Total Ratio (S/T) Dry Bulb (°F)	Total Cool Cap. (Btuh)	Comp. Motor Watts Input	Sensible To Total Ratio (S/T) Dry Bulb (°F)								
														76	80	84	76	80	84	76	80
63	7000	241,000	21,360	.75	.85	.96	230,000	22,820	.76	.87	.98	218,400	24,150	.78	.90	1.00	206,500	25,290	.80	.92	1.00
	8500	249,000	21,720	.79	.91	1.00	237,300	23,190	.80	.93	1.00	225,300	24,520	.82	.96	1.00	213,000	25,650	.85	.99	1.00
	10,000	256,200	22,040	.83	.96	1.00	244,400	23,510	.85	.99	1.00	231,200	24,830	.87	1.00	1.00	219,800	26,030	.90	1.00	1.00
67	7000	259,900	22,210	.59	.69	.79	247,500	23,680	.60	.70	.81	234,400	24,990	.61	.72	.83	221,100	26,090	.62	.74	.86
	8500	267,200	22,520	.61	.73	.84	253,900	23,980	.62	.74	.86	240,100	25,280	.64	.76	.89	226,000	26,360	.65	.79	.92
	10,000	273,100	22,770	.64	.77	.89	259,200	24,230	.65	.79	.92	244,700	25,520	.67	.81	.95	230,300	26,580	.69	.84	.98
71	7000	279,500	23,050	.45	.54	.64	265,800	24,530	.45	.55	.65	251,500	25,840	.46	.56	.67	236,900	26,920	.46	.57	.69
	8500	286,600	23,340	.46	.57	.67	272,100	24,810	.46	.58	.69	257,100	26,100	.47	.59	.71	241,700	27,170	.48	.60	.73
	10,000	292,500	23,580	.47	.59	.71	277,300	25,030	.48	.60	.73	261,600	26,310	.48	.62	.75	245,700	27,360	.49	.64	.78

CHA11-3003 COOLING CAPACITY (With One Compressor Only Operating)

Enter. Wet Bulb (°F)	Total Air Vol. (cfm)	Outdoor Air Temperature Entering Condenser Coil (°F)																			
		65			75			85			95										
		Total Cool Cap. (Btuh)	Comp. Motor Watts Input	Sensible To Total Ratio (S/T) Dry Bulb (°F)	Total Cool Cap. (Btuh)	Comp. Motor Watts Input	Sensible To Total Ratio (S/T) Dry Bulb (°F)	Total Cool Cap. (Btuh)	Comp. Motor Watts Input	Sensible To Total Ratio (S/T) Dry Bulb (°F)	Total Cool Cap. (Btuh)	Comp. Motor Watts Input	Sensible To Total Ratio (S/T) Dry Bulb (°F)								
														76	80	84	76	80	84	76	80
63	7000	153,400	11,000	.70	.79	.87	146,700	11,830	.71	.80	.89	139,600	12,610	.72	.82	.91	132,400	13,340	.73	.84	.94
	8500	158,700	11,210	.73	.83	.93	151,600	12,060	.74	.85	.95	144,200	12,870	.76	.87	.97	136,600	13,620	.77	.89	1.00
	10,000	163,100	11,380	.76	.88	.98	155,700	12,250	.78	.90	1.00	148,100	13,090	.80	.92	1.00	140,800	13,860	.82	.95	1.00
67	7000	164,000	11,410	.56	.65	.73	156,800	12,300	.57	.65	.74	149,200	13,150	.57	.67	.76	141,400	13,940	.58	.68	.78
	8500	169,100	11,600	.58	.68	.77	161,500	12,250	.59	.69	.79	153,400	13,390	.60	.70	.81	145,200	14,190	.61	.72	.83
	10,000	173,200	11,780	.60	.71	.82	165,100	12,700	.61	.72	.84	156,700	13,580	.62	.74	.86	148,200	14,390	.63	.76	.89
71	7000	174,900	11,840	.44	.52	.60	167,000	12,790	.44	.52	.61	159,000	13,710	.44	.53	.62	150,800	14,560	.45	.54	.63
	8500	179,800	12,040	.45	.54	.63	171,700	13,010	.45	.54	.64	163,100	13,940	.45	.55	.65	154,400	14,810	.46	.56	.67
	10,000	183,800	12,200	.45	.56	.66	175,200	13,180	.46	.57	.67	166,400	14,120	.46	.58	.69	157,400	15,000	.47	.59	.71

CHA11-3003 TOTAL COOLING CAPACITY (With Both Compressors Operating)

Enter. Wet Bulb (°F)	Total Air Vol. (cfm)	Outdoor Air Temperature Entering Condenser Coil (°F)																			
		85			95			105			115										
		Total Cool Cap. (Btuh)	Comp. Motor Watts Input	Sensible To Total Ratio (S/T) Dry Bulb (°F)	Total Cool Cap. (Btuh)	Comp. Motor Watts Input	Sensible To Total Ratio (S/T) Dry Bulb (°F)	Total Cool Cap. (Btuh)	Comp. Motor Watts Input	Sensible To Total Ratio (S/T) Dry Bulb (°F)	Total Cool Cap. (Btuh)	Comp. Motor Watts Input	Sensible To Total Ratio (S/T) Dry Bulb (°F)								
														76	80	84	76	80	84	76	80
63	7000	279,200	25,220	.72	.82	.91	264,600	26,690	.73	.84	.94	249,500	28,020	.74	.86	.96	234,100	29,170	.77	.89	1.00
	8500	288,400	25,740	.76	.87	.97	273,000	27,260	.77	.89	1.00	257,300	28,640	.79	.92	1.00	241,400	29,830	.82	.95	1.00
	10,000	296,100	26,180	.80	.92	1.00	280,300	27,750	.82	.95	1.00	264,600	29,170	.84	.98	1.00	247,600	30,400	.87	1.00	1.00
67	7000	298,300	26,300	.57	.67	.76	282,700	27,890	.58	.68	.78	266,400	29,340	.59	.69	.80	249,600	30,580	.60	.71	.82
	8500	307,000	26,780	.60	.70	.81	290,200	28,410	.61	.72	.83	273,100	29,880	.62	.74	.86	255,700	31,130	.64	.76	.89
	10,000	313,400	27,150	.62	.74	.86	296,200	28,800	.63	.76	.89	278,500	30,300	.64	.79	.92	260,800	31,570	.67	.81	.95
71	7000	318,100	27,410	.44	.53	.62	301,200	29,140	.45	.54	.63	284,100	30,720	.45	.55	.65	266,200	32,090	.45	.56	.66
	8500	326,400	27,880	.45	.55	.65	308,800	29,640	.46	.56	.67	290,600	31,240	.46	.57	.69	272,300	32,610	.47	.59	.71
	10,000	332,800	28,240	.46	.58	.69	314,600	30,020	.47	.59	.71	295,700	31,630	.48	.60	.73	276,800	33,010	.48	.62	.76

BLOWER DATA

CHA11-2753 BLOWER PERFORMANCE

Air Volume (cfm)	STATIC PRESSURE EXTERNAL TO UNIT – (Inches Water Gauge)											
	.20	.30	.40	.50	.60	.70	.80	.90	1.00	1.10	1.30	1.50
	RPM BHP	RPM BHP	RPM BHP	RPM BHP	RPM BHP	RPM BHP	RPM BHP	RPM BHP	RPM BHP	RPM BHP	RPM BHP	RPM BHP
7000	560 1.85	610 2.15	650 2.50	690 2.80	725 3.05	760 3.30	800 3.55	835 3.75	870 4.00	900 4.40	960 5.20	1015 5.90
7200	570 2.05	620 2.30	660 2.70	700 3.00	735 3.20	770 3.50	805 3.70	840 4.00	880 4.20	905 4.55	965 5.35	1020 6.10
7400	585 2.20	630 2.45	670 2.85	710 3.15	740 3.35	775 3.65	810 3.85	850 4.15	885 4.40	910 4.70	970 5.50	1025 6.25
7600	595 2.35	640 2.60	680 2.95	715 3.25	750 3.55	785 3.80	820 4.10	855 4.35	890 4.65	915 4.90	975 5.65	1030 6.45
7800	610 2.55	650 2.80	690 3.10	725 3.45	760 3.70	790 3.95	825 4.20	860 4.50	895 4.80	920 5.10	980 5.80	1035 6.65
8000	620 2.70	660 2.95	700 3.30	735 3.60	770 3.85	800 4.10	830 4.35	870 4.65	900 4.95	930 5.25	985 6.00	1040 6.80
8200	630 2.85	670 3.10	710 3.50	745 3.75	780 4.00	810 4.25	840 4.50	880 4.85	910 5.15	935 5.45	990 6.20	1045 7.00
8400	645 3.05	680 3.30	720 3.65	755 3.95	790 4.15	815 4.40	850 4.70	885 5.05	915 5.30	940 5.60	995 6.35	1050 7.15
8600	655 3.20	695 3.45	730 3.85	765 4.10	800 4.35	825 4.60	860 4.85	895 5.25	920 5.50	945 5.80	1000 6.55	1055 7.35
8800	670 3.40	705 3.65	740 4.00	775 4.30	805 4.50	830 4.75	865 5.05	900 5.40	930 5.65	955 6.00	1010 6.70	1060 7.50
9000	680 3.55	715 3.80	750 4.20	785 4.45	815 4.65	840 4.90	875 5.20	910 5.60	935 5.85	960 6.15	1015 6.90	1065 7.70
9200	690 3.75	725 4.05	760 4.40	795 4.65	825 4.85	850 5.15	885 5.45	920 5.80	945 6.05	970 6.40	1020 7.15	1070 7.95
9400	700 3.95	735 4.25	770 4.60	800 4.85	830 5.05	860 5.35	895 5.65	925 6.00	950 6.30	975 6.60	1030 7.40	1075 8.20
9600	715 4.15	750 4.50	780 4.75	810 5.05	840 5.30	875 5.60	905 5.90	935 6.25	960 6.50	985 6.85	1035 7.60	1080 8.40
9800	725 4.35	760 4.70	785 4.95	815 5.25	850 5.50	885 5.80	915 6.10	940 6.45	965 6.75	990 7.05	1045 7.85	----
10,000	735 4.55	770 4.95	795 5.15	825 5.45	855 5.70	895 6.05	925 6.35	950 6.65	975 6.95	1000 7.30	1050 8.10	----

NOTE -- All cfm data is measured external to the unit with the air filters in place. See page 42 for Accessory Air Resistance data table.

CHA11-3003 BLOWER PERFORMANCE

Air Volume (cfm)	STATIC PRESSURE EXTERNAL TO UNIT – (Inches Water Gauge)											
	.20	.30	.40	.50	.60	.70	.80	.90	1.00	1.20	1.30	1.50
	RPM BHP	RPM BHP	RPM BHP	RPM BHP	RPM BHP	RPM BHP	RPM BHP	RPM BHP	RPM BHP	RPM BHP	RPM BHP	RPM BHP
7000	715 2.35	755 2.60	790 2.85	830 3.15	860 3.55	890 3.90	920 4.30	950 4.65	985 5.00	1020 5.40	1040 5.75	1065 5.90
7200	730 2.60	770 2.80	805 3.10	845 3.40	875 3.80	905 4.20	935 4.55	965 4.90	1000 5.25	1030 5.65	1055 5.90	1080 6.15
7400	745 2.75	785 3.05	820 3.30	855 3.65	890 4.05	920 4.40	950 4.80	980 5.15	1010 5.50	1045 5.90	1070 6.20	1095 6.45
7600	760 3.00	800 3.25	835 3.55	865 3.90	905 4.30	935 4.65	965 5.10	995 5.35	1025 5.70	1060 6.20	1085 6.45	1110 6.70
7800	775 3.15	815 3.45	850 3.75	890 4.20	915 4.45	945 4.85	980 5.30	1010 5.65	1040 6.05	1075 6.45	1100 6.75	1130 7.00
8000	790 3.30	830 3.65	865 4.05	900 4.40	930 4.75	965 5.15	995 5.55	1025 5.95	1050 6.30	1085 6.70	1110 7.05	1140 7.55
8200	810 3.60	845 3.90	880 4.25	915 4.65	940 5.00	980 5.45	1010 5.85	1035 6.20	1060 6.50	1095 7.00	1125 7.40	1150 7.80
8400	825 3.75	860 4.20	895 4.55	925 4.85	960 5.35	1000 5.85	1020 6.10	1050 6.50	1070 6.75	1110 7.25	1135 7.75	1165 8.25
8600	840 4.00	875 4.40	910 4.80	940 5.20	975 5.65	1015 6.10	1035 6.35	1060 6.70	1080 7.00	1120 7.55	1150 8.10	1180 8.50
8800	855 4.25	890 4.65	925 5.10	955 5.50	995 5.95	1025 6.35	1050 6.70	1070 7.00	1085 7.25	1135 8.00	1165 8.50	----
9000	870 4.55	905 5.00	935 5.35	970 5.75	1010 6.25	1040 6.65	1060 6.90	1075 7.25	1095 7.50	1145 8.30	----	----
9200	890 4.90	920 5.25	955 5.70	990 6.05	1020 6.45	1050 6.95	1070 7.25	1085 7.50	1110 7.85	----	----	----
9400	905 5.15	940 5.70	970 6.00	1005 6.45	1040 6.90	1060 7.20	1080 7.60	1100 7.90	1125 8.30	----	----	----
9600	925 5.50	950 5.90	985 6.30	1020 6.75	1045 7.10	1070 7.50	1085 7.80	1115 8.15	1135 8.65	----	----	----
9800	935 5.80	965 6.15	1005 6.70	1035 7.10	1060 7.50	1080 7.85	1100 8.20	1130 8.65	----	----	----	----
10,000	955 6.20	985 6.55	1020 7.00	1050 7.45	1070 7.80	1090 8.20	1115 8.60	----	----	----	----	----

NOTE -- All cfm data is measured external to the unit with the air filter in place. See page 42 for Accessory Air Resistance data table.

BLOWER DATA

CHA11-2753 AND CHA11-3003 ACCESSORY AIR RESISTANCE

Air Volume cfm	Total Air Resistance (inches water gauge)					Electric Heat All Models
	REMD11M Econo-mizer	RTD11 Diffuser			FD11 Diffuser	
		2 Sides Open	3 Sides Open	4 Sides Open		
7000	.033	.42	.34	.31	.36	.06
7200	.035	.45	.37	.32	.38	.07
7400	.036	.48	.39	.35	.40	.07
7600	.038	.51	.42	.37	.43	.07
7800	.039	.55	.46	.40	.47	.08
8000	.041	.58	.49	.43	.48	.08
8200	.043	.63	.53	.46	.53	.08
8400	.045	.67	.56	.49	.56	.09
8600	.047	.71	.60	.52	.59	.09
8800	.048	.73	.63	.55	.63	.10
9000	.050	.79	.67	.58	.66	.10
9200	.052	.84	.70	.61	.69	.11
9400	.054	.87	.73	.64	.72	.11
9600	.055	.92	.77	.67	.75	.12
9800	.057	.96	.81	.70	.78	.12
10,000	.059	1.00	.84	.73	.81	.13

CHA11-2753 AND CHA11-3003 CEILING DIFFUSER AIR THROW DATA

Air Volume (cfm)	*Effective Throw Range (feet)	
	RTD11 Step Down	FD11 Flush
8000	39 – 44	53 – 62
9000	47 – 56	55 – 64
10,000	49 – 58	57 – 67

*Throw is the horizontal or vertical distance an air stream travels on leaving the outlet of diffuser before the maximum velocity is reduced to 50 ft. per minute.

CHA11-2753 AND CHA11-3003 POWER EXHAUST FANS PERFORMANCE

Air Volume (Cfm Exhausted)	Return Air System Static Pressure (Inches Water Gauge)
7050	0
6550	.05
6100	.10
5600	.15
5100	.20
4600	.25

COMBINATION CEILING SUPPLY AND RETURN AIR DIFFUSERS DIMENSIONS (inches)

RTD11-275 STEP-DOWN CEILING DIFFUSER

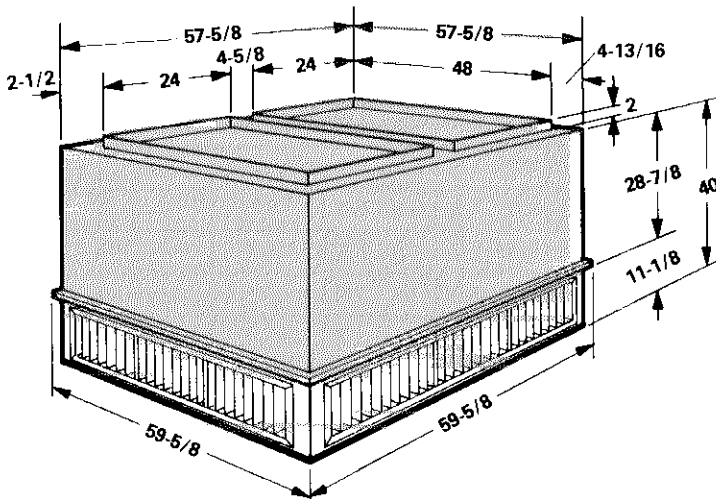

FD11-275 FLUSH CEILING DIFFUSER

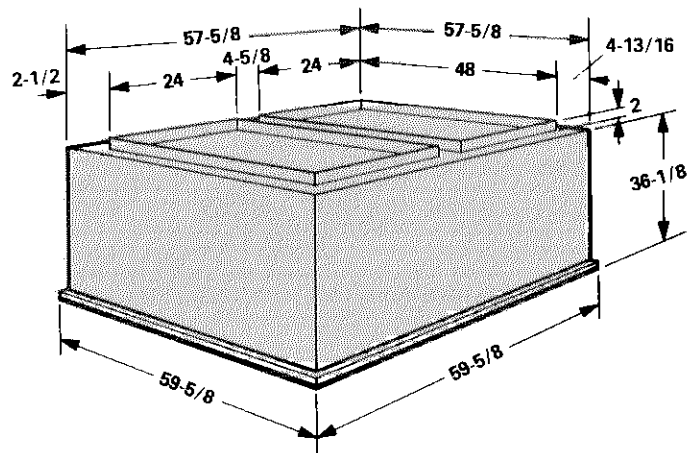

DIMENSIONS (inches)

CORNER WEIGHTS (lbs.)

Model No.		A	B	C	D
CHA11-2753 CHA11-3003	Basic Unit	787	729	665	719
	With Economizer	875	770	723	821
	With Economizer/Exhaust Fans	904	795	768	873

CENTER OF GRAVITY (in.)

Model No.		E	F
CHA11-2753 CHA11-3003	Basic Unit	37-1/2	67-3/4
	With Economizer	36-1/2	68-3/4
	With Economizer/Exhaust Fans	36-1/2	69-3/4

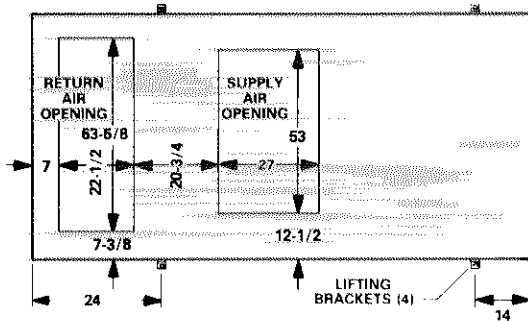

TOP VIEW BASE SECTION

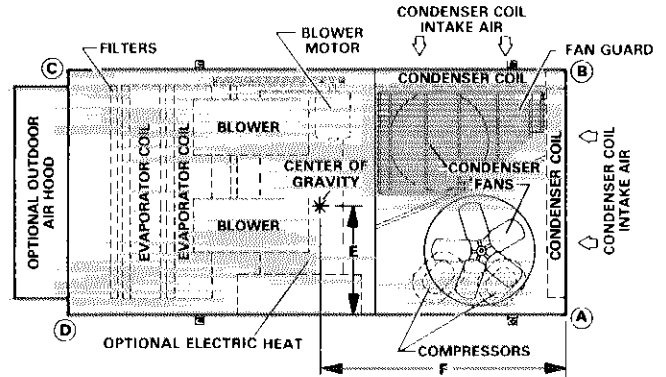

TOP VIEW

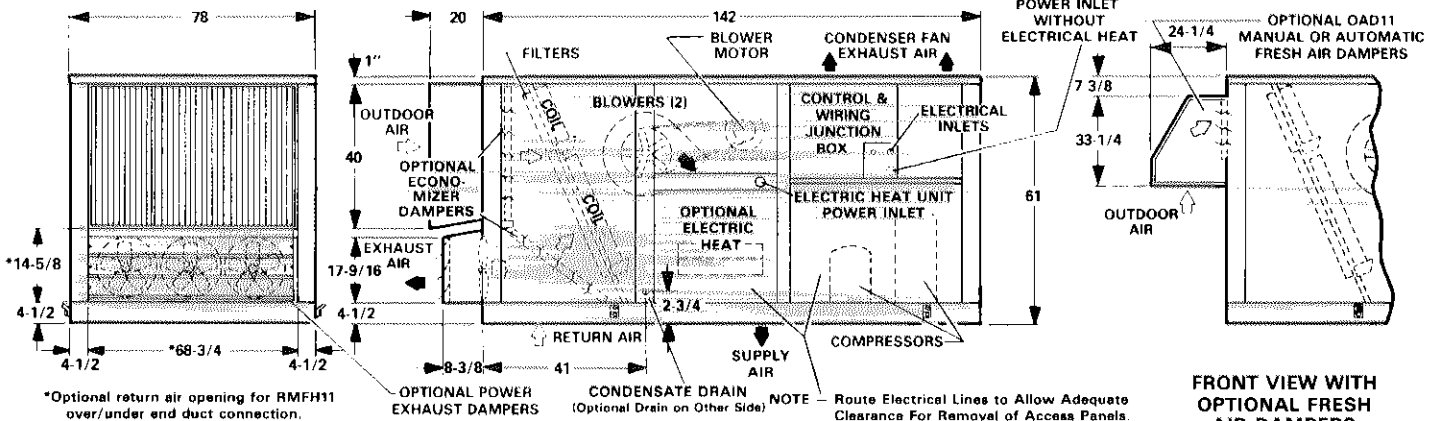

FRONT VIEW

EXHAUST & OUTDOOR AIR INTAKE VIEW

FRONT VIEW WITH OPTIONAL FRESH AIR DAMPERS

INSTALLATION CLEARANCES (inches)

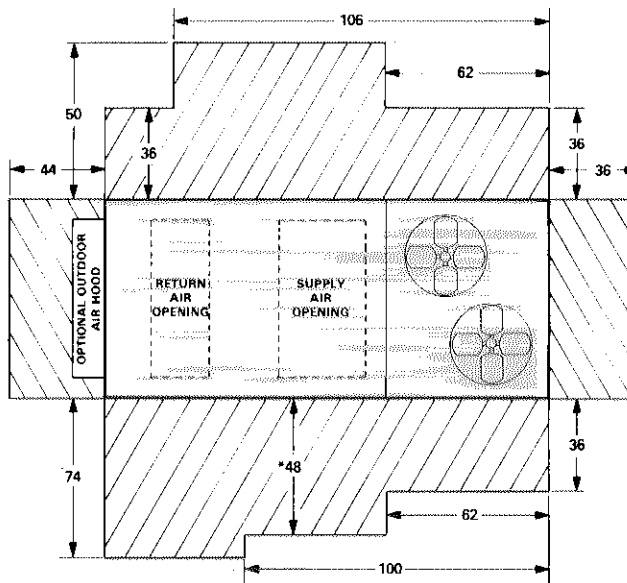

TYPICAL FLASHING DETAIL FOR RMF11 ROOF MOUNTING FRAME

ROOF MOUNTING FRAME SPECIFICATIONS

Roof Mounting frame is rigid enough to be spanned over its entire length or cantilevered if supported on either side of the center of gravity.

Mounting Frame Height	RMF11	RMFH11
*Frame moment of inertia (I) (in. ⁴)	68	517
*Frame section modulus $\frac{I}{C}$ (in. ³)	10.0	36.8
Mounting frame weight (lb./foot of length)	9.8	13.5
Mounting frame design strength (psi)	20,000	20,000

*Includes both sides of frame.

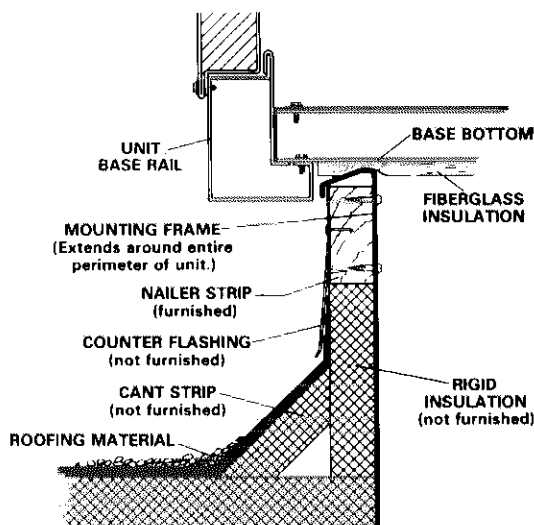

DIMENSIONS (inches)

RMF11-275 ROOF MOUNTING FRAME WITH DOUBLE DUCT OPENING

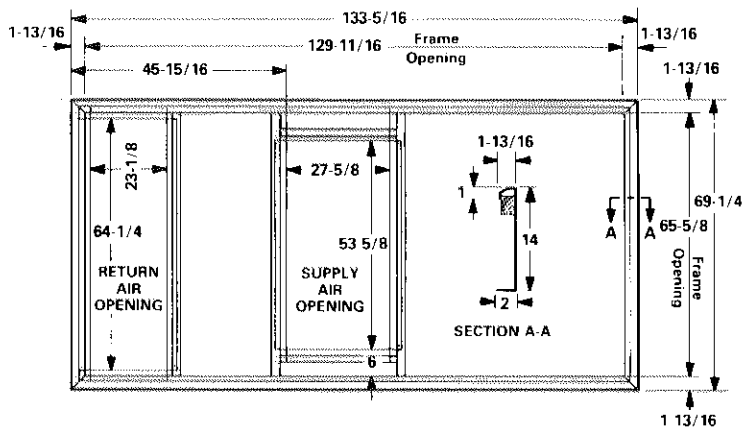

PLENUM SUPPORT ANGLE DETAIL

NOTE — Plenum support angles (furnished) must be field installed around perimeter of both supply and return air openings.

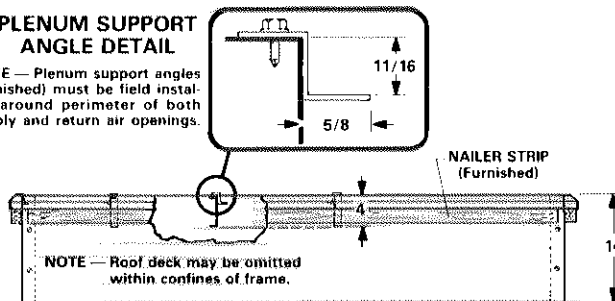

RMF11-275 ROOF MOUNTING FRAME WITH SRT11-275 SUPPLY AND RETURN TRANSITIONS FOR FD11 & RTD11-275 DIFFUSERS

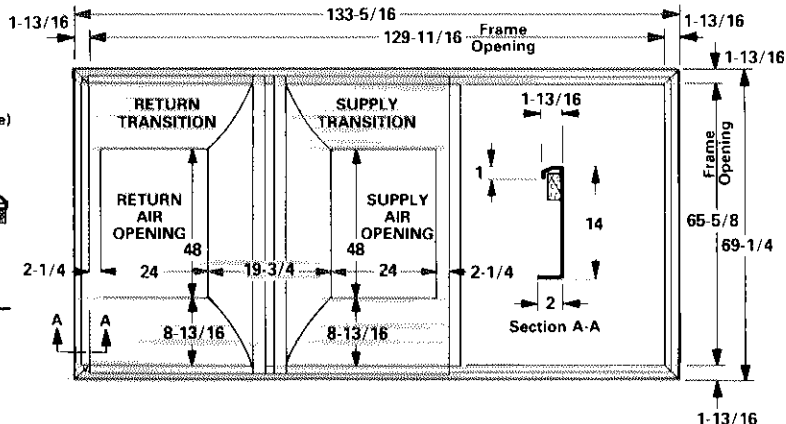
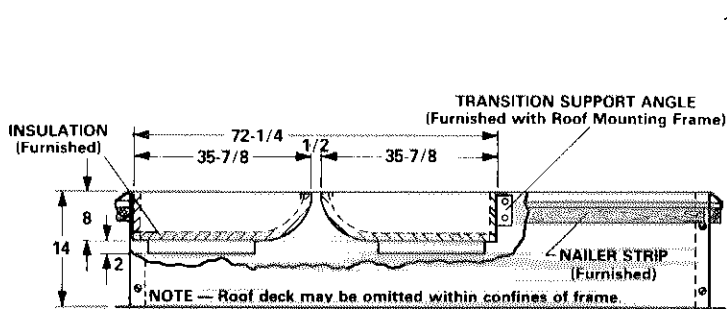

DIMENSIONS (inches)

RMFH11-275 HORIZONTAL ROOF MOUNTING FRAME

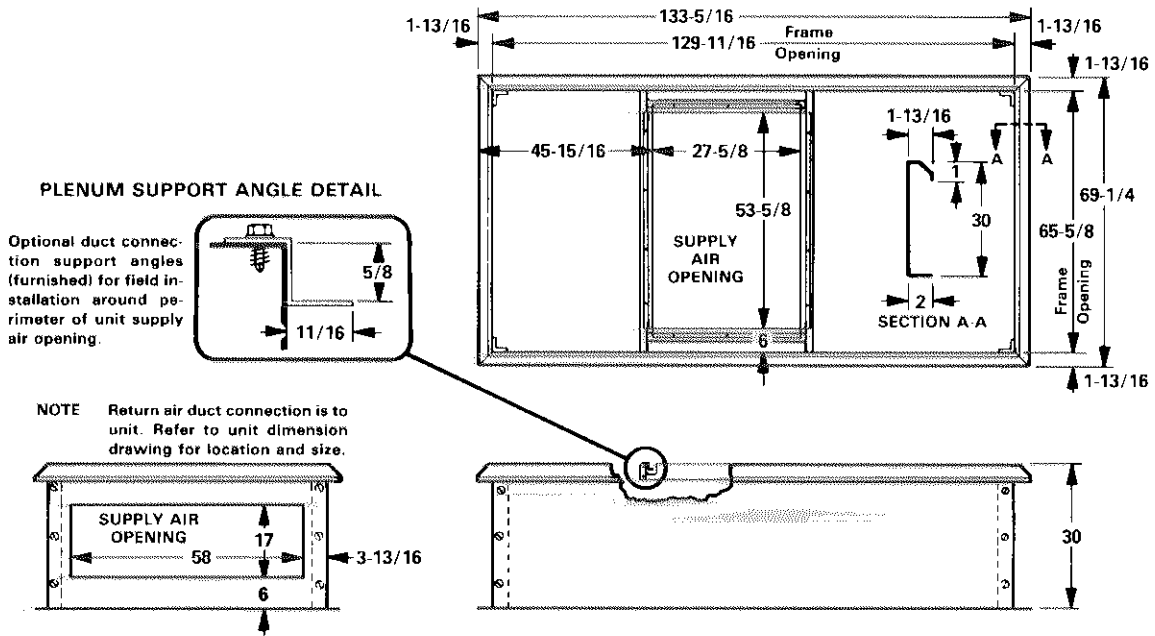

RMFA11-275 ADAPTER ROOF MOUNTING FRAME

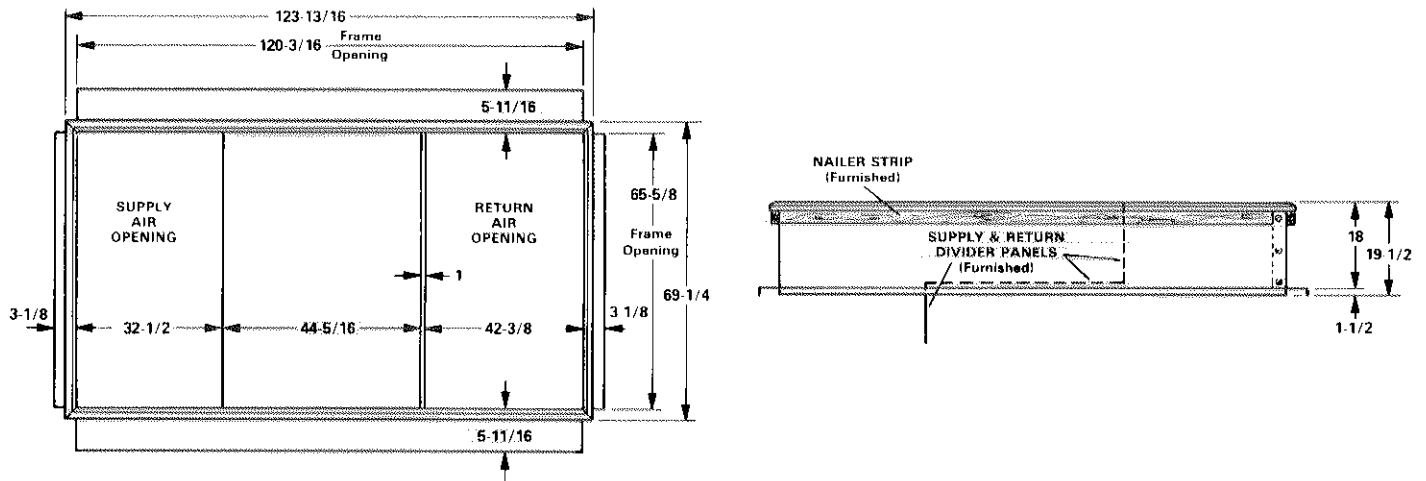

TYPICAL FLASHING DETAIL FOR RMFA11 WITH RMF3 ROOF MOUNTING FRAME

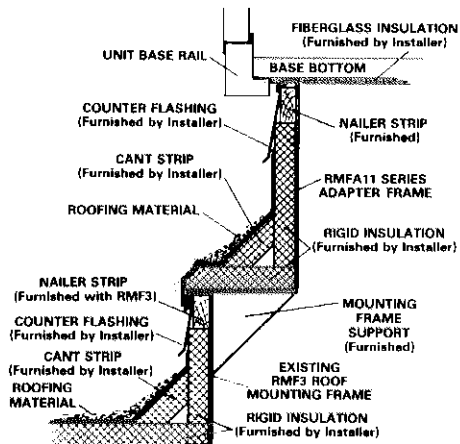

RMFA11 ADAPTER ROOF MOUNTING FRAME WITH RMF3 ROOF MOUNTING FRAME

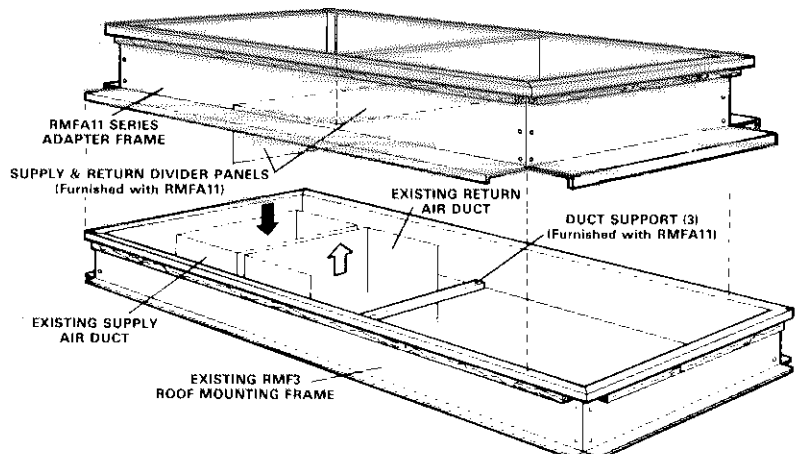

GUIDE SPECIFICATIONS

Prepared for the guidance of architects, consulting engineers and mechanical contractors.

General — Furnish and install a single package air to air DX mechanical cooling system complete with automatic controls. The single package unit shall be a standard product of a firm regularly engaged in the manufacture of heating-cooling equipment. The manufacturer shall have parts and service available throughout the United States.

The installed weight shall not be more than lbs. Entire unit shall have a width of not more than inches, a depth of not more than inches and an overall height of not more than inches. The equipment shall be shipped completely factory assembled, precharged, piped and wired internally ready for field connections. In addition, manufacturer shall test operate system at the factory before shipment.

Air Distribution — Equipment shall be capable of bottom or end (horizontal) handling of conditioned air. All air distribution ducts shall be fiberglass or ga. galvanized steel insulated with inch thick lb. density fiberglass or equivalent.

Approvals — All electrical components shall have U.L. Listing. All wiring shall be in compliance with NEC.

Equipment Warranty — Compressors have a limited warranty for a full five years. All other components have a limited warranty for one year. Refer to the Lennox Equipment Limited Warranty certificate included with the unit for details.

Cooling System — The total certified cooling capacity shall not be less than Btuh with an evaporator air volume of cfm, an entering wet bulb air temperature of °F, an entering dry bulb air temperature of °F and a condenser entering temperature of °F. The compressor power input shall not exceed kw at these conditions.

The coils shall be non-ferrous construction with aluminum fins mechanically bonded to durable copper tubes. Coils shall be pressure leak tested. Coil face area shall be not less than sq. ft. (evaporator) and sq. ft. (condenser).

Dual compressors shall be resiliently mounted, have overload protection, internal pressure relief and crankcase heater. The refrigeration system shall have suction and liquid line service gauge ports, sight glasses, high pressure switches, loss of charge switches, driers and full refrigerant charge. Control option available shall consist of low ambient control and timed off control. CHA11-2753 shall be rated in accordance with ARI Standard 360-86. CHA11-3003 shall be rated at ARI Standard 360 test conditions.

Additive Electric Heaters — The certified total heating capacity output shall be Btuh with kw input at volts power supply.

Optional electric heaters shall be available. Heating elements shall be nichrome bare wire exposed directly to the air stream. Time delays shall bring the elements on and off in sequence with a time delay between each element. Limit controls shall provide overload and short circuit protection.

Cabinet — Shall be galvanized steel with a paint finish of powder enamel. Cabinet panels where conditioned air is handled shall be fully insulated to prevent sweating and minimize sound. Openings shall be provided for power connection entry. Base shall have drainage holes. Lifting lugs shall be provided for rigging.

Service Access — All components, wiring and inspection areas shall be completely accessible through removable panels.

Supply Air Blowers — Dual centrifugal supply air blower shall have permanently lubricated ball bearings and adjustable belt drive and motor mount where belt tension can be easily adjusted. The entire assembly shall be floated on resilient rubber mounts. Blower wheel shall be statically and dynamically balanced. Blower shall be capable of delivering cfm at an external static pressure of inches water gauge requiring bhp and rpm.

Condenser Fans — Twin propeller type condenser fans shall discharge vertically and be direct driven by a hp motor. Fan motor shall be totally enclosed with sleeve bearings, permanently lubricated, inherently protected and equipped with rain shield. Fan shall have a safety guard.

Air Filters — 1" thick disposable frame type fiberglass media filters shall have not less than sq. ft. of free area.

OPTIONAL ACCESSORIES

Roof Mounting Frame — Furnish and install a steel roof mounting frame for bottom or horizontal discharge and return air duct connection. It shall mate to the bottom perimeter of the equipment. When flashed into the roof it shall make a unit mounting curb and provide weatherproof duct connection and entry into the conditioned area. Flashing shall be the responsibility of a roofing contractor. Frame shall be approved by National Roofing Contractors Association.

Economizer Dampers — Furnish and install complete with controls an optional mechanically linked air mixing damper assembly including outdoor air and recirculated air dampers. The assembly shall mount within the confines of the unit cabinet and provide for the introduction of outside air for minimum ventilation and free cooling. Outdoor air hood shall mount external to the unit cabinet. Damper motor shall be 24 volt, fully modulating spring return. Controls shall include discharge air sensor, minimum position switch, and solid-state adjustable outdoor air enthalpy control. Control option shall consist of differential enthalpy control (return air sensor).

Fresh Air Dampers — Outdoor air damper section shall control outdoor air requirements and be available for manual or automatic operation. Dampers shall be adjustable for air quantities up to 25%. Shall include cleanable air filter.

Gravity Exhaust Air Dampers — Pressure operated dampers shall install within the unit. Damper blades shall ride in nylon bearings and be gasketed for tight seal and quiet operation.

Power Exhaust Air Dampers — Direct drive propeller type fans shall exhaust air through pressure relief dampers. Motors shall be overload protected. Pressure operated dampers shall install within the unit and prevent blow back and outdoor air infiltration during the fan off cycle. Damper blades shall ride in nylon bearings and be gasketed for tight seal and quiet operation.

Ceiling Diffusers — Furnish and install a (flush or stepdown) optional combination ceiling supply and return air diffuser. It shall be capable of not less than ft. radius of effective throw. Supply and return transitions shall be available, for field installation in the roof mounting frame, to provide duct connection to the diffuser.

Remote Status Panel — Shall be available for installation within the conditioned area to observe equipment operation. The panel shall include signal lights for Cool Mode, Heat Mode, Compressor 1, Compressor 2, No Heat and Filter.

Remote Switching Status Panel — Shall be available for installation within the conditioned area to control and observe equipment operation. The panel shall include signal lights for Cool Mode, Heat Mode, Compressor 1, Compressor 2, No Heat and Filter. System selector switch and fan switch shall provide operational mode and blower operation. After hours timer switch shall override night setback controls and provide normal operation for time period set.

Control Systems — Shall provide a selection of optional thermostats and related controls to automatically operate the mechanical equipment through the heating or cooling and ventilating cycles as required.