

LENNOX®

CHA11-953 & CHA11-1353 SINGLE PACKAGE AIR CONDITIONERS

*89,000 to 121,000 Btuh Cooling Capacity

35,500 to 204,800 Btuh Optional Electric Heat

100,000 to 275,000 Btuh Optional Hot Water Heat

*At ARI Standard 210 Test Conditions

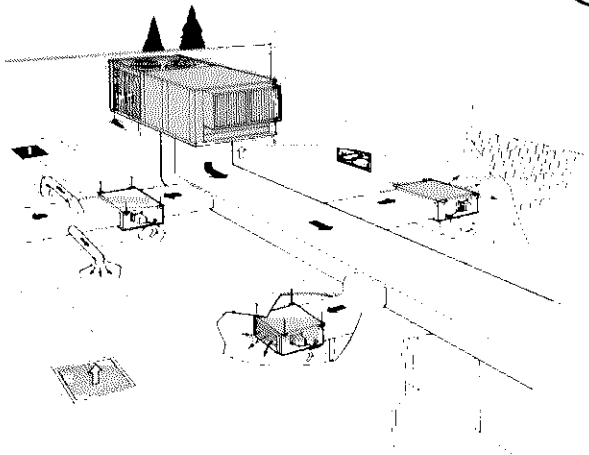
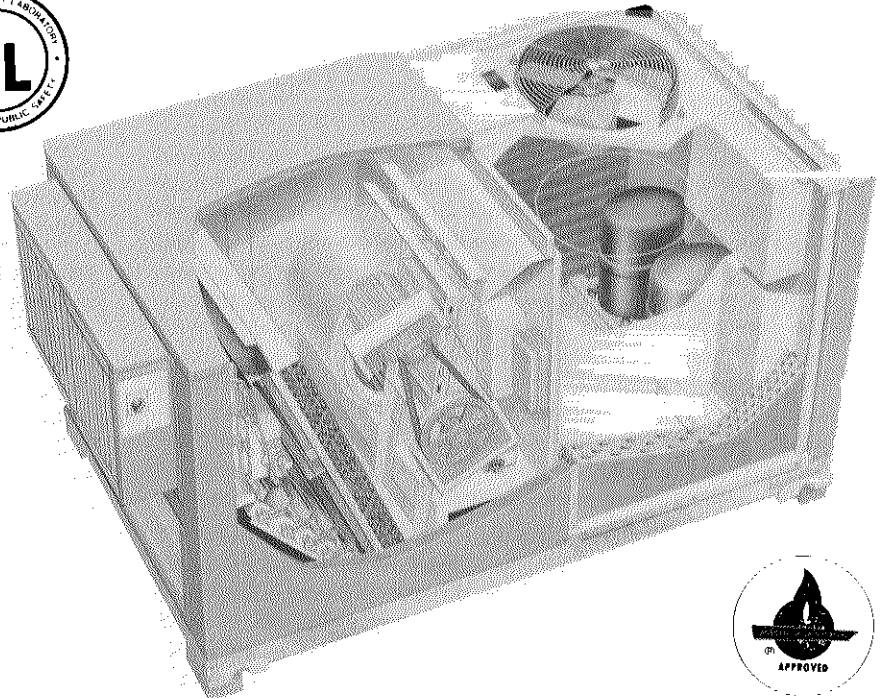

Rooftop Installation with Optional ZDB1 Blower Powered Mixing Damper Boxes.

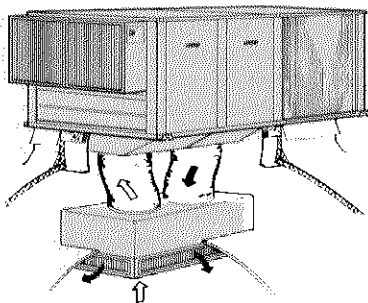

Rooftop Installation with Combination Ceiling Supply and Return Air System

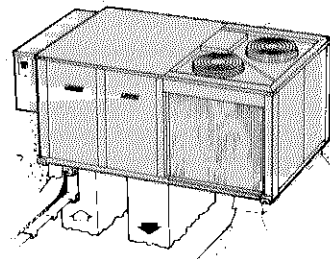

Rooftop Installation with Double Duct Air Distribution System

High Efficiency Rooftop Units Feature Energy Saving Operation, Low Operating Cost and Application Flexibility

Lennox single package CHA11-953 and CHA11-1353 units are designed for rooftop installation with bottom or side handling of supply and return air. A separate roof mounting frame (optional) mates to the bottom of the unit and when flashed into the roof permits weatherproof duct connection and entry into the structure. No additional roof curbing or flashing is required. The roof mounting frame is shipped knocked down and must be field assembled.

Units are available for cooling only, cooling with electric heat or cooling with hot water heat. Four voltage options provide a choice for power supply requirements.

Energy and operational cost saving features include: Demand oriented solid-state electronic control system. Dual refrigerant circuits to control system capacity and reduce energy usage. POWER SAVER® option will provide "free cooling" by using outdoor air in lieu of mechanical refrigeration. POWER SAVER Enthalpy control provides maximum

use of the outdoor air for "free" cooling. Two staging of electric heaters and modulating control of the hot water heat minimizes energy usage for the heating options available.

Units have been tested in the Lennox Laboratory environmental test room according to ARI Standard 210 Test Conditions. Additionally, units have been tested in the Lennox sound test room according to ARI Standard 270. Units coming within the scope of this standard (135,000 Btuh or less) carry the ARI Certification seal and are certified under the ARI certification program. Blower data is from unit tests in the Lennox air test chamber. Units are C.G.A. certified, U.L. Listed and components within are bonded for grounding to meet safety standards for servicing required by U.L. and NEC.

Units are shipped completely factory assembled, piped, and wired. In addition, each unit is test operated at the factory insuring unit dependability and reducing start-up problems.

NOTE - Specifications, Ratings and Dimensions subject to change without notice.



FEATURES

Lennox Solid-State Control System — Energy savings electronic control system measures the deviation between room temperature and set point and then controls the supply air temperature to meet the load requirements. The control system consists of a dual set point room thermostat located in the conditioned space or a dual set point transmitter with a remote temperature sensor in the conditioned space, a discharge temperature sensor located in the supply air duct of the unit, Logic Panel installed in the unit and a modulating damper actuator for the POWER SAVER dampers. This solid-state control system will operate the unit to automatically match its output to the load with minimum space temperature variation. To accomplish this the room thermostat or transmitter, in the conditioned space, is continuously comparing space temperature deviation with supply air temperature and sending a varying load signal to the logic panel. The heat-cool relays in the logic panel respond to the signal and cycle the stages of heating or cooling and POWER SAVER position to match the output to the load condition. To maintain stable space temperatures the Logic Panel balances the space thermostat demand signal against the system output. System output is measured by the discharge temperature sensor in the supply air duct. The combined demand and output signals determine POWER SAVER position and number of heating or cooling stages energized. The discharge sensor also provides a positive modulating low limit signal to the Logic Panel ensuring that the POWER SAVER will modulate closed if the discharge air gets too cold. Additionally on power failure, system recycles all stages to off. When power is restored system sequences stages back on with a time delay between stages.

Durable Cabinet — Rugged leaktight cabinet is constructed of heavy gauge galvanized steel. Cabinet is subject to a five station zinc phosphate metal wash process resulting in a perfect bonding surface for a paint finish of baked-on outdoor enamel. Long lasting enamel finish provides maximum protection from the weather. Large removable panels allow complete service access. Electrical inlets are provided in the cabinet for wiring entry. Wiring junction box and control boxes with all controls factory installed are conveniently located for service access. Lifting brackets are furnished on each corner of the base for ease of handling and rigging. Drainage holes in base rails provide moisture removal.

Cabinet Insulation — Base section and cabinet panels exposed to conditioned air are lined with thick fiberglass insulation. This results in quiet and efficient operation due to the excellent acoustical and insulating qualities of fiberglass. The cabinet panels have 3 inch thick 1/2 lb. density fiberglass insulation and the base 1/2 inch thick 6 lb. density. Insulation is sandwiched between the cabinet panel and a galvanized steel panel liner protecting the insulation indefinitely. It will never erode or tear away from a panel to clog or impair unit operation.

Refrigeration System — Factory sealed refrigerant system consists of compressors, condenser coils and direct drive fans, evaporator (dual circuits) coil and blower, expansion valves, high capacity driers, high and low pressure switches, refrigerant lines connected and a full operating charge of refrigerant. Dual independent refrigerant circuits provide staging control to fit varying cooling loads.

Lennox Evaporator and Condenser Coils — Extra large surface area and circuiting of Lennox designed coils provide maximum cooling efficiency, excellent heat transfer and low air resistance. Lennox fabricated coils are constructed of precisely spaced ripple-edged aluminum fins fitted to durable copper tubes. Fins are equipped with collars that grip tubing for maximum contact area. Flared shoulder tubing connections and silver soldering provide tight, leakproof joints. Long life copper tubing is easy to field service. Coil is thoroughly factory tested under high pressure to insure leakproof construction. The evaporator coil is face split with two separate circuits. Each circuit has its separate expansion valve, condensing coil, fan, compressor and refrigerant charge.

Drain Pan — Deep, corrosion resistant evaporator coil drain pan is constructed of heavy gauge galvanized steel. Drain pipes extend outside of cabinet on both sides for convenient and easy connections.

Dependable, Quiet Compressors — Reliable, dual compressors are hermetically sealed and provide trouble free operation and long service life. Built in protection devices assure protection from excessive current and temperature. Suction cooled, overload protected and equipped with internal pressure relief. Low ambient lock-out control prevents compressor operation below 20°F degrees. The entire running gear assembly is spring mounted within the sealed housing. In addition, the compressor is installed in the unit on resilient rubber mounts assuring quiet and vibration free operation.

Compressor Crankcase Heater — Furnished and factory installed. Prevents migration of liquid refrigerant into the compressor and ensures proper compressor lubrication at all times.

Efficient Condenser Fans — Two direct drive fans draw large air volumes uniformly through dual condenser coils and discharges it vertically, up and away from the building. Fan orifice design and low fan tip speed keeps operating sound level at a minimum. Uniform air flow through the coils result in high refrigerant cooling capacity. Permanently lubricated, overload protected, sleeve bearing fan motor is totally enclosed for maximum protection from rain, dust and corrosion. A rain shield on the motor provides additional protection from moisture. Motor is resiliently mounted. Corrosion resistant PVC coated steel wire fan guards are furnished.

Powerful Supply Air Blower — Belt drive centrifugal blower delivers large air volume efficiently and with minimum power consumption. Blower assembly is mounted to rugged angle iron frame with the entire blower and frame assembly vibration isolated on rubber mounts. Ball bearings are permanently sealed and lubricated. Blower wheel is statically and dynamically balanced. Design of motor mounting base permits quick and simple motor changeover, belt tension adjustment or belt changing. A choice of motor horsepower and drives is available. Adjustable motor pulley allows for variable speed adjustments. Motor is overload protected. Drives are covered with a protective guard.

Air Filters — One inch thick frame type throwaway filters are furnished as standard. Fiberglass media is oil impregnated for increased efficiency. Filters are easily accessible for quick and simple replacement.

Optional Electric Heat — Available factory or field installed in 15 kw through 60 kw sizes. Helix wound nichrome heating elements are exposed directly in the air stream resulting in instant heat transfer, lower coil temperatures and long service life. Elements are accurately located and insulated from the heavy gauge steel support frame by high quality insulators. Time delays bring the elements on and off the line in sequence and equal increments in response to demand with a time delay between each element. Elements are equipped with individual limit controls providing positive protection in case of excessive overheating. Heaters may be two stage controlled with each stage being energized only when required.

Optional Hot Water Heat — A factory installed hot water coil is equipped with a three-way modulating valve. Factory installed freeze-stat activates valve to circulate water during freezing conditions. A glycol solution may also be used in the system to provide freeze protection. Lennox designed and built coil has large face area, excellent heat transfer and low air resistance. Constructed of precisely spaced ripple-edged aluminum fins fitted to durable copper tubes. Durable copper tubing assures long service life and easy servicing. Each joint is silver soldered and coil is factory tested under pressure to insure leakproof construction.

Optional Blower Powered Mixing Damper Boxes — ZDB1 series mixing air boxes with a cfm range of 270 to 1900 are available for zone control system applications. Units install in the duct system within the structure. For data see Accessories section, page 7.

Thermostat Choice — Dual set point room thermostat (25C52) or transmitter (25C51) with a choice of remote sensors is available. Both have separate heating - cooling locking set points concealed under the cover and do not have indicating thermometer. The room thermostat has integral sensor and installs in the conditioned space. For remote temperature control the transmitter installs outside the conditioned space with a remote sensor (58C92) in the conditioned area or a return air sensor (27C40) in the return air duct of the unit. Sensor must be ordered extra. If desired in multiple unit applications, that serve a common space, up to six units can be controlled from a single thermostat. Thermostat and transmitter are furnished with a wiring wallplate and may be installed horizontally or vertically. In addition, an optional switching subbase (58C93) is available and must be ordered extra. It is equipped with system selector switch (HEAT — AUTO — COOL — OFF) and fan switch (AUTO — ON). Fan switch provides a choice of intermittent (AUTO) or continuous (ON) blower operation. A voltage control relay (51C21) is required with the switching subbase and must be ordered extra. Relay provides blower operation for Power Saver. Both the thermostat and transmitter will mount on a standard 2 x 4 inch electrical outlet box.

Optional SP11 Remote Status Panel — The operation of the unit can be checked at a glance on the Remote Status Panel (25C91) conveniently located within the conditioned area. Signal lights on the panel indicate "Cool Mode", "Heat Mode", Compressor 1, "Compressor 2", "No Heat" and "Filter". The cool mode signal light is green when lit and indicates Power Saver operation or DX cooling operation for units without Power Saver. Heat Mode light is green and reflects heating operation. Compressor 1 and compressor 2 lights are green when operating and will turn red if there is an operational malfunction. The No Heat and Filter lights will show red and indicate a requirement for service. Additional controls are required for use with the Status Panel and must be specified when ordering. Filter switch kit (59C95) is used in conjunction with the Filter light. Units with electric heat require a current sensing relay (59C94) for operation of No Heat light. Units with hot water heat require a proving relay (51C22) for operation of No Heat light.

Optional SSP11 Remote Switching Status Panel — The operation of the unit can be controlled and observed on the Switching Status Panel (59C00) conveniently located within the conditioned area. Signal lights on the panel indicate "Cool Mode", "Heat Mode", "Compressor 1", "Compressor 2", "No Heat" and "Filter". The Cool Mode signal light is green when lit and indicates Power Saver operation or DX cooling operation for units without Power Saver. Heat Mode light is green and reflects heating operation will light red when switched to emergency heat mode. Compressor 1 and Compressor 2 lights are green when operating and will turn red if there is an operational malfunction. The No Heat and Filter lights will show red and indicates a requirement for service. Additionally panel is equipped with a system selector switch (OFF — HEAT — AUTO — COOL — EMERGENCY HEAT (Heat Pump Only), fan switch (AUTO — ON) and after hours timer. Fan switch provides a choice of intermittent (AUTO) or continuous (ON) blower operation. Manually operated after hours timer (0 to 12 hours) overrides night setback controls providing normal operation for time period set. A momentary push button switch is used to initiate the time period. Additional controls are required for use with the Status Panel and must be specified when ordering. Voltage control relay (51C21) provides blower operation for Power Saver and field installs remote to the unit. Filter switch kit (59C95) is used in conjunction with the Filter light. Units with electric heat require a current sensing relay (59C94) for operation of No Heat light. Units with hot water heat require a proving relay (51C22) for operation of No Heat light.

Optional RMF11 Roof Mounting Frame — Sturdy mounting frame mates to the single package unit and provides an automatic weather sealed rooftop installation. Shipped knocked down for ease of shipping and handling it is easily field assembled. A 2 x 4 nailer is secured to the frame sides to facilitate flashing. Approved by National Roofing Contractors Association.

Optional RMFH11 Roof Mounting Frame — Horizontal discharge frame adapts to the RMF11 frame for horizontal (side by side) supply and return air applications. Shipped knocked down for ease of shipping and handling it is easily field assembled. A 2" x 4" nailer strip is secured to the frame sides to facilitate flashing. See dimension drawing and installation detail sketch.

Optional RMFA11 Roof Mounting Frame — Retrofit adapter frame is available for CHA11 model replacement of existing CHA8 unit installations. The RMFA11 frame adapts to the existing RMF3 frame and provides a weather sealed connection with minimum installation cost. RMFA11 frame is shipped knocked down for ease of shipping and handling, it is easily field assembled. A 2" x 4" nailer strip is secured to the frame sides to facilitate flashing. See dimensions drawing and installation detail sketch.

Optional PSD11 Power Saver — Available factory or field installed. Lennox Power Saver system consists of: mechanically linked outdoor air and recirculated air dampers. Damper blades are gasketed for tight seal and quiet operation. Formed damper blades rotate smoothly in nylon bearings. The positioning of these dampers is accomplished by a 24 volt modulating spring return damper actuator and controlled by the room thermostat or transmitter, discharge sensor and enthalpy control. The enthalpy control allows (0 to 100%) outdoor air to be used for "free" cooling when outdoor air humidity and temperature is acceptable. A outdoor air hood with rain eliminator vanes is furnished and field installs over the outdoor air dampers external to the unit. For field installation the two damper sections slide in cavities provided in the unit cabinet. Power Saver is shipped factory wired and only requires plug-in field connection.

Optional OAD11 Minimum Fresh Air Dampers — Damper assembly field installs inside the unit cabinet and is available for manual or automatic operation. Damper assembly allows a fixed amount of outdoor air into the system and can be adjusted for air quantities of 0 to 100%. Outdoor air hood with rain eliminator vanes is included and installs over the dampers external to the unit. Automatic damper operation is available with the addition of a spring return modulating damper actuator. Actuator only requires plug-in connection for operation. Order Automatic Fresh Air Damper Kit 41C53. Kit also includes adjustable potentiometer for minimum fresh air setting.

Optional GED11 Gravity Exhaust Air Dampers — Damper assembly field installs in space provided in the unit cabinet. Pressure operated extruded aluminum dampers operate smoothly in nylon bearings. Damper blades are equipped with seal gaskets for tight seal and quiet operation.

Optional Night Setback Control Kit — Kit (LB-38134CB) is available for field installation in the unit. 24 hour skip day clock with carry-over automatically programs the unit for night setback operation. The system room thermostat or transmitter controls both day and night operation.

Optional Low Ambient Control Kit — System will operate satisfactorily down to 35°F outdoor air temperature without additional controls. If air conditioning operation is required below 35° a field installed low ambient control kit (LB-37124B) can be added enabling the unit to operate down to 0°F.

Optional Disconnect Mounting Kit — Disconnect mounting kit (LB-38208BA) provides a convenient mounting location for field furnished remote disconnect switch. Kit field installs to outside of unit cabinet adjacent to electrical inlets.

SPECIFICATIONS

Model No.		CHA11-953	CHA11-1353
★ARI Standard 270 SRN		21	22
*ARI Standard 210 Ratings	Total cooling capacity (Btuh)	89,000	121,000
	Total unit watts	11,100	15,100
	†EER (Btuh/Watts)	8.0	8.0
	Dehumidifying capacity	29%	31%
Refrigerant (22) charge		15 lbs. 2 oz.	22 lbs.
Evaporator Blower	Blower wheel nominal diam. x width (in.)	(1) 15 x 9	(1) 15 x 15
	Motor horsepower (minimum-maximum)	1-1/2 — 3	3 — 5
Evaporator Coil	Net face area (sq. ft.)	8.3	12.0
	Tube diam. (in.) & No. of rows	1/2 — 3	1/2 — 3
	Fins per inch	15	15
Condenser Coil	Net face area (sq. ft.)	14.6	19.8
	Tube diam. (in.) & No. of rows	3/8 — 3	3/8 — 3
	Fins per inch	20	20
Condenser Fans	Diameter (in.) & No. of blades	(2) 20 — 4	(2) 24 — 4
	Air volume (cfm) (factory setting)	6000	8500
	Motor horsepower	(2) 1/3	(2) 1/2
	Motor watts (factory setting)	850	1150
Optional Hot Water Coil	Model No. & Net weight	HWC11-95 (65 lbs.)	HWC11-135 (75 lbs.)
	**Heating capacity range (Btuh)	100,000 — 250,000	100,000 — 275,000
	Net face area (sq. ft.)	4.5	6.5
	Tube diameter (in.) — No. of rows	1/2 — 2	1/2 — 2
	Fins per inch	16	10
Condensate drain size mpt (in.)		(2) 3/4	(2) 3/4
No. & size of filters (in.)		(4) 16 x 20 x 1	(6) 16 x 20 x 1
Net weight of basic unit (lbs.) (1 Package)		1205	1585
Optional Roof Mounting Frame — (Net weight)		RMF11-95 (150 lbs.)	RMF11-135 (180 lbs.)
		RMFH11-95 (205 lbs.)	RMFH11-135 (245 lbs.)
		RMFA11-95 (255 lbs.)	RMFA11-135 (290 lbs.)
Optional Power Saver & Controls — (Net weight)		PSD11-95 (97 lbs.)	PSD11-135 (163 lbs.)
Optional Gravity Exhaust Dampers (Net weight)		GED11-95 (13 lbs.)	GED11-135 (18 lbs.)
Optional Ceiling Supply & Return Step-Down Diffuser — (Net weight)		RTD11-95 (84 lbs.)	RTD11-135 (95 lbs.)
Optional Ceiling Supply & Return Flush Diffuser — (Net weight)		FD11-95 (84 lbs.)	FD11-135 (95 lbs.)
Optional Ceiling Supply & Return Transitions — (Net weight)		SRT11-95 (28 lbs.)	SRT11-135 (32 lbs.)
Optional Minimum Fresh Air Dampers (Manual) — (Net weight)		OAD11-95 (57 lbs.)	OAD11-135 (114 lbs.)
Optional Automatic Fresh Air Damper Kit — (Net weight)		34C23 (15 lbs.)	34C23 (15 lbs.)
Optional Remote Status Panel		SP11 (25C91)	SP11 (25C91)
Optional Remote Switching Status Panel		SSP11 (59C00)	SSP11 (59C00)
Optional Disconnect Mounting Kit		LB-38208BA (10 lbs.)	LB-38208BA (10 lbs.)
††Optional Powered Mixing Damper Boxes		ZDB1-400 (51 lbs.), ZDB1-800 (76 lbs.), ZDB1-1200 (108 lbs.) & ZDB1-1600 (119 lbs.)	
Electrical characteristics		200 to 575 volt — 60 hertz — 3 phase	

*Sound Rating Number in accordance with ARI Standard 270.

*Rated in accordance with ARI Standard 210; 450 cfm (maximum) evaporator air volume per ton of cooling, 95F outdoor air temperature and 80db/67wb entering evaporator air.

†Energy Efficiency Ratio in accordance with ARI Standard 210.

**Capacity range shown is possible with varying supply conditions and air volumes. See coil capacity curves.

††See bulletin (Page 7) in Accessories section for complete data.

ELECTRICAL DATA

Model No.	CHA11-953								CHA11-1353									
	200V		230V		460V		575V		200V		230V		460V		575V			
Line voltage data — 60hz — 3 phase																		
Compressors (2)	Rated load amps (total)		30.6		28.2		16.0		11.2		38.0		38.0		14.7			
	Locked rotor amps (total)		148.0		148.0		74.0		72.0		264.0		264.0		112.0			
Condenser Fan Motors (2)	Full load amps (total)		4.6		4.2		2.2		1.6		6.8		6.0		2.4			
	Locked rotor amps (total)		9.4		9.4		4.6		4.0		12.4		12.4		5.8			
Evaporator Blower Motor	Horsepower		1-1/2	3	1-1/2	3	1-1/2	3	1-1/2	3	3	5	3	5	3	5		
	Full load amps		6.0	11.0	5.2	9.6	2.6	4.8	2.1	3.9	11.0	17.5	9.6	15.2	4.8	7.6	3.9	6.1
	Locked rotor amps		39.0	65.0	34.0	56.0	17.0	28.0	15.0	25.6	65.0	100.0	56.0	90.0	28.0	45.0	25.6	35.0
Recommended max. fuse size (amps)		50	60	50	50	30	30	20	20	70	80	70	70	35	35	30	30	
Unit Power Factor		.89	.88	.89	.88	.89	.88	.89	.88	.89	.88	.89	.88	.89	.88	.89	.88	
*Minimum Circuit Ampacity		45.0	50.0	41.1	45.5	22.8	25.0	16.4	18.1	60.6	67.1	58.4	64.0	28.9	31.7	22.9	25.1	

*Refer to National Electrical Code manual to determine wire, fuse and disconnect size requirements.

NOTE — Extremes of operating range are plus and minus 10% of line voltage.

FIELD WIRING

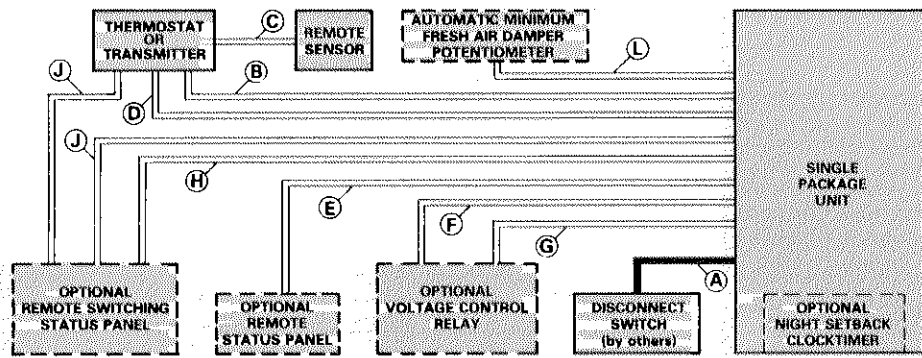

- A — Three wire power (See Electrical Data Table)
- B — Seven wire low voltage — DC only
Five wire low voltage — DC only (with Remote Switching Status Panel Only)
- C — Two wire low voltage — DC only (with transmitter)
- D — Two wire low voltage — AC only (with sub-base)
- E — Nine wire low voltage — AC only
- F — Three wire low voltage — DC only (with Remote Switching Status Panel or sub-base and Power Saver)
- G — Two wire low voltage — AC only (with Remote Switching Status Panel or subbase and Power Saver)
- H — Twelve wire low voltage — AC only
- J — Two wire low voltage — DC only
- L — Three wire low voltage — DC only

- Note - Field wiring not furnished -

NOTE — All wiring must be in accordance with regulations of the National Electrical Code (NEC).

CHA11-953 OPTIONAL ELECTRIC HEAT DATA

Electric Heat Model No. & Net Weight	No. of Steps	Volts Input	Kw Input	Btuh Output	*Minimum Circuit Ampacity	
					1-1/2 hp	3 hp
ECH11-95-15 (52 lbs.)	1	200	10.4	35,500	47.0	53.3
		210	11.5	39,200		
		220	12.6	43,000		
		230	13.8	47,100		
		240	15.0	51,200		
	1	440	12.6	43,000	25.8	28.5
		460	13.8	47,100		
		480	15.0	51,200		
		550	12.5	42,700		
		575	13.7	46,800		
†TECH11-95-30 (56 lbs.)	2	200	20.8	71,000	---	92.8
		210	23.0	78,500		
		220	25.2	86,000		
		230	27.5	93,900		
		240	30.0	102,400		
	1	440	25.2	86,000	---	51.1
		460	27.5	93,900		
		480	30.0	102,400		
		550	25.0	85,300		
		575	27.6	94,200		
†TECH11-95-45 (59 lbs.)	3	200	31.3	106,800	---	132.4
		210	34.5	117,700		
		220	37.8	129,000		
		230	41.3	141,000		
		240	45.0	153,600		
	2	440	37.8	129,000	---	73.6
		460	41.3	141,000		
		480	45.0	153,600		
		550	37.5	128,000		
		575	41.3	141,000		
†TECH11-95-60 (64 lbs.)	4	200	41.7	142,300	---	171.9
		210	46.0	157,000		

*Refer to National Electrical Code manual to determine wire, fuse and disconnect size requirements. Use wires suitable for at least 75°C (167°F).

††May be used with two stage control.

† NOTE — ECH11-95-30, ECH11-95-45 and ECH11-95-60 is not available with 1-1/2 hp motor.

CHA11-1353 OPTIONAL ELECTRIC HEAT DATA

Electric Heat Model No. & Net Weight	No. of Steps	Volts Input	Kw Input	Btuh Output	*Minimum Circuit Ampacity	
					3 hp	5 hp
ECH11-135-15 (46 lbs.)	1	200	10.4	35,500	53.3	67.1
		210	11.5	39,200		
		220	12.6	43,000		
		230	13.8	47,100		
		240	15.0	51,200		
	1	440	12.6	43,000	28.5	32.0
		460	13.8	47,100		
		480	15.0	51,200		
		550	12.5	42,700		
		575	13.7	46,000		
TECH11-135-30 (50 lbs.)	2	200	20.8	71,000	92.8	100.9
		210	23.0	78,500		
		220	25.2	86,000		
		230	27.5	93,900		
		240	30.0	102,400		
	1	440	25.2	86,000	51.1	54.6
		460	27.5	93,900		
		480	30.0	102,400		
		550	25.0	85,300		
		575	27.6	94,200		
TECH11-135-45 (53 lbs.)	3	200	31.3	106,800	132.4	140.5
		210	34.5	117,700		
		220	37.8	129,000		
		230	41.3	141,000		
		240	45.0	153,600		
	2	440	37.8	129,000	73.6	77.1
		460	41.3	141,000		
		480	45.0	153,600		
		550	37.5	123,000		
		575	41.3	141,000		
TECH11-135-60 (58 lbs.)	4	200	41.7	142,300	171.9	180.0
		210	46.0	157,000		
		220	50.4	172,000		
		230	55.1	188,100		
		240	60.0	204,800		
	2	440	50.4	172,000	96.3	99.8
		460	55.1	188,100		
		480	60.0	204,800		
		550	50.0	170,700		
		575	55.1	188,100		
2	600	60.0	204,800	77.0	79.8	

*Refer to National Electrical Code manual to determine wire, fuse and disconnect size requirements. Use wires suitable for at least 75°C (167°F).

††May be used with two stage control.

RATINGS

CHA11-953 COOLING CAPACITY — 1st Stage

Evaporator Air 80F Dry Bulb		Outdoor Air Temperature Entering Condenser (F)											
Entering Wet Bulb Degrees (F)	Total Air Volume (cfm)	65			75			85			95		
		Total Cooling Capacity (Btuh)	Sensible To Total Ratio (S/T)	Comp. Motor Watts Input	Total Cooling Capacity (Btuh)	Sensible To Total Ratio (S/T)	Comp. Motor Watts Input	Total Cooling Capacity (Btuh)	Sensible To Total Ratio (S/T)	Comp. Motor Watts Input	Total Cooling Capacity (Btuh)	Sensible To Total Ratio (S/T)	Comp. Motor Watts Input
63	3000	50,900	.82	3630	48,600	.84	3820	46,300	.87	4040	43,800	.90	4290
	3375	52,000	.86	3670	49,700	.87	3870	47,300	.91	4090	44,800	.94	4340
	3750	53,100	.88	3710	50,700	.91	3910	48,500	.94	4130	45,500	.99	4390
67	3000	54,900	.66	3780	52,300	.68	3980	49,500	.68	4200	46,800	.71	4460
	3375	55,900	.69	3810	53,300	.70	4010	50,500	.71	4240	47,500	.74	4490
	3750	56,700	.71	3840	54,100	.72	4040	51,300	.74	4270	48,000	.77	4530
71	3000	59,100	.52	3920	56,400	.53	4130	53,500	.53	4370	50,500	.54	4630
	3375	60,100	.54	3960	57,200	.55	4170	54,300	.55	4410	51,000	.56	4670
	3750	61,000	.55	3990	58,000	.55	4200	55,000	.57	4440	51,500	.58	4700

CHA11-953 TOTAL COOLING CAPACITY

Evaporator Air 80F Dry Bulb		Outdoor Air Temperature Entering Condenser (F)											
Entering Wet Bulb Degrees (F)	Total Air Volume (cfm)	85			95			105			115		
		Total Cooling Capacity (Btuh)	Sensible To Total Ratio (S/T)	Comp. Motor Watts Input	Total Cooling Capacity (Btuh)	Sensible To Total Ratio (S/T)	Comp. Motor Watts Input	Total Cooling Capacity (Btuh)	Sensible To Total Ratio (S/T)	Comp. Motor Watts Input	Total Cooling Capacity (Btuh)	Sensible To Total Ratio (S/T)	Comp. Motor Watts Input
63	3000	92,500	.87	8080	87,500	.90	8580	82,000	.93	9140	76,000	.96	9760
	3375	94,500	.91	8180	89,500	.94	8680	84,500	.97	9240	78,500	1.00	9920
	3750	97,000	.94	8260	91,000	.99	8780	86,000	1.00	9400	80,500	1.00	10,080
67	3000	99,000	.68	8400	93,500	.71	8920	87,000	.73	9480	81,000	.76	10,100
	3375	101,000	.71	8480	95,000	.74	8980	89,000	.76	9540	82,000	.80	10,180
	3750	102,500	.74	8540	96,000	.77	9060	90,000	.80	9640	83,500	.84	10,260
71	3000	107,000	.53	8740	101,000	.54	9260	94,000	.56	9860	87,000	.58	10,500
	3375	108,500	.55	8820	102,000	.56	9340	95,000	.58	9940	88,000	.60	10,580
	3750	110,000	.57	8880	103,000	.58	9400	96,000	.60	10,000	89,000	.63	10,640

CHA11-1353 COOLING CAPACITY — 1st Stage

Evaporator Air 80F Dry Bulb		Outdoor Air Temperature Entering Condenser (F)											
Entering Wet Bulb Degrees (F)	Total Air Volume (cfm)	65			75			85			95		
		Total Cooling Capacity (Btuh)	Sensible To Total Ratio (S/T)	Comp. Motor Watts Input	Total Cooling Capacity (Btuh)	Sensible To Total Ratio (S/T)	Comp. Motor Watts Input	Total Cooling Capacity (Btuh)	Sensible To Total Ratio (S/T)	Comp. Motor Watts Input	Total Cooling Capacity (Btuh)	Sensible To Total Ratio (S/T)	Comp. Motor Watts Input
63	4000	68,700	.79	5010	65,600	.81	5310	62,800	.84	5600	59,500	.86	6000
	4500	69,900	.83	5080	66,800	.85	5390	63,800	.87	5680	60,500	.90	6090
	5000	71,000	.81	5090	67,900	.88	5450	64,800	.90	5750	61,300	.93	6140
67	4000	73,100	.64	5260	69,900	.66	5580	66,800	.67	5870	63,000	.69	6280
	4500	74,100	.67	5330	70,800	.68	5640	67,500	.70	5920	64,000	.72	6330
	5000	75,100	.69	5380	71,700	.71	5690	68,300	.73	5980	64,800	.75	6360
71	4000	77,600	.51	5520	74,200	.51	5840	71,000	.52	6120	67,300	.53	6560
	4500	78,700	.52	5580	75,300	.53	5900	72,000	.54	6180	68,000	.55	6620
	5000	79,600	.54	5630	76,000	.55	5950	72,800	.56	6220	68,800	.57	6660

CHA11-1353 TOTAL COOLING CAPACITY

Evaporator Air 80F Dry Bulb		Outdoor Air Temperature Entering Condenser (F)											
Entering Wet Bulb Degrees (F)	Total Air Volume (cfm)	85			95			105			115		
		Total Cooling Capacity (Btuh)	Sensible To Total Ratio (S/T)	Comp. Motor Watts Input	Total Cooling Capacity (Btuh)	Sensible To Total Ratio (S/T)	Comp. Motor Watts Input	Total Cooling Capacity (Btuh)	Sensible To Total Ratio (S/T)	Comp. Motor Watts Input	Total Cooling Capacity (Btuh)	Sensible To Total Ratio (S/T)	Comp. Motor Watts Input
63	4000	125,500	.84	11,200	119,000	.86	12,000	112,500	.89	12,920	105,500	.92	14,000
	4500	127,500	.87	11,360	121,000	.90	12,180	114,500	.92	13,100	107,500	.96	14,200
	5000	129,500	.90	11,500	122,500	.93	12,280	116,500	.96	13,280	110,000	1.00	14,440
67	4000	133,500	.67	11,740	126,000	.69	12,560	119,000	.71	13,520	111,500	.74	14,620
	4500	135,000	.70	11,840	128,000	.72	12,660	120,500	.74	13,620	113,500	.77	14,740
	5000	136,500	.73	11,960	129,500	.75	12,780	122,000	.77	13,740	114,500	.80	14,860
71	4000	142,000	.52	12,240	134,500	.53	13,120	127,000	.55	14,120	119,000	.56	15,300
	4500	144,000	.54	12,360	136,000	.55	13,240	128,000	.57	14,260	120,500	.59	15,440
	5000	145,500	.56	12,440	137,500	.57	13,320	129,500	.59	14,340	121,500	.61	15,540

DIMENSIONS (inches)

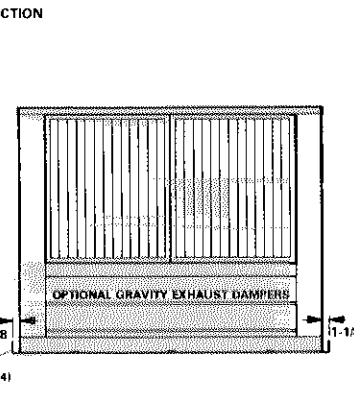
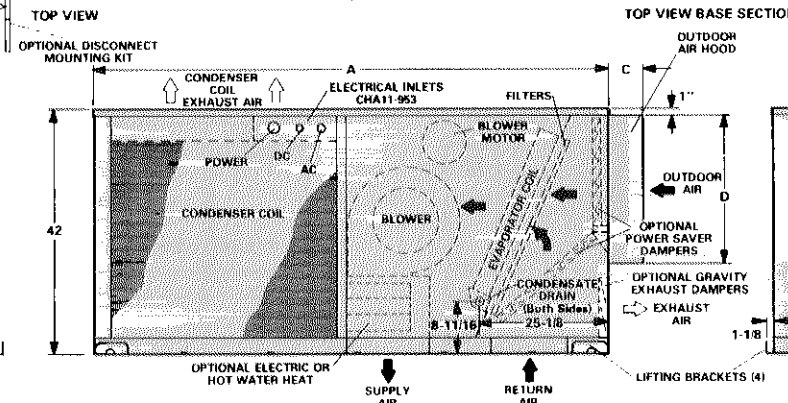
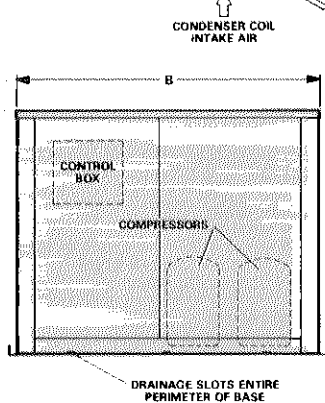
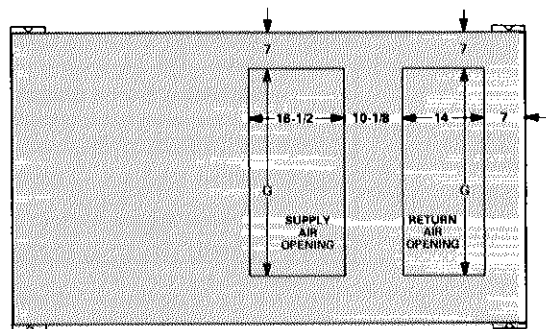
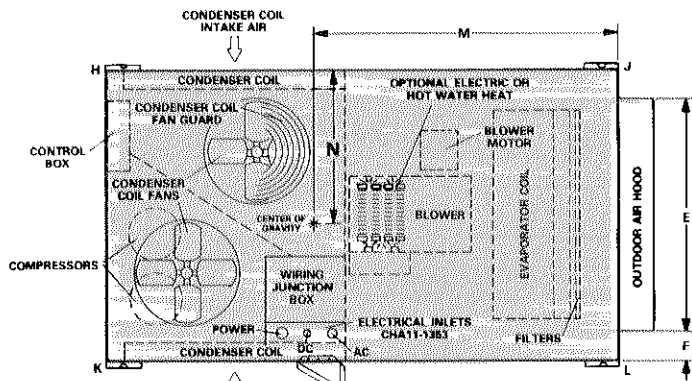

COMPRESSOR END VIEW

SIDE VIEW

EXHAUST & OUTDOOR AIR INTAKE END VIEW

Model No.	A	B	C	D	E	F	G
CHA11-953	87-7/8	50	6-1/8	20-3/4	40-3/4	4-1/2	35-9/16
CHA11-1353	93-3/8	68	14-1/8	32	63	2-3/8	53-9/16

CORNER WEIGHTS (lbs.)

Model No.		H	J	K	L
CHA11-953	With Power Saver	335	309	350	321
	Without Power Saver	334	256	348	267
CHA11-1353	With Power Saver	419	451	431	465
	Without Power Saver	419	362	431	373

CENTER OF GRAVITY (in.)

Model No.		M	N
CHA11-953	With Power Saver	45-3/4	25-1/2
	Without Power Saver	49-1/2	25-1/2
CHA11-1353	With Power Saver	45	34-1/2
	Without Power Saver	50	34-1/2

RECOMMENDED FLASHING FOR RMF11 ROOF MOUNTING FRAME

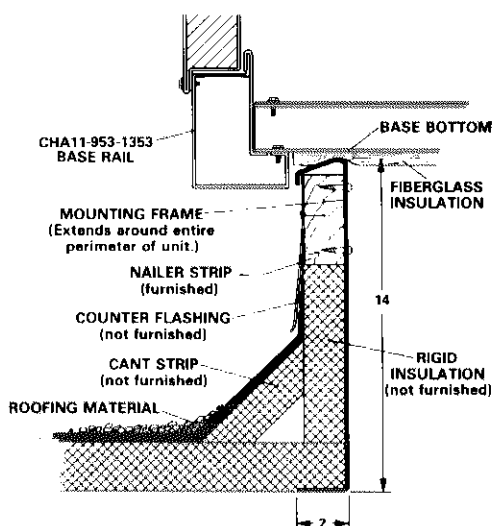

INSTALLATION CLEARANCES (inches)

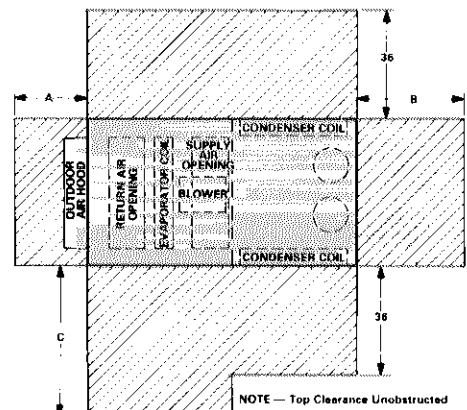

Model No.	A	B	C
CHA11-953	24	36	50
CHA11-1353	32	44	68

DIMENSIONS (inches)

ROOF MOUNTING FRAME SPECIFICATIONS

Roof Mounting frame is rigid enough to be spanned over its entire length or cantilevered if supported on either side of the center of gravity.

Mounting Frame Height	RMF11	†RMFH-11 & RMF11	
		CHA11-953	CHA11-1353
*Frame moment of inertia (I) (in. ⁴)	86	88	88
*Frame section modulus $\frac{I}{C}$ (in. ³)	12.3	12.3	12.3
Mounting frame weight (lb./foot of length)	6.2	8.8	10.0
Mounting frame design strength (psi)	20,000	20,000	20,000

*Includes both sides of frame.

†Horizontal frame application includes RMF11 frame

RMF11 ROOF MOUNTING FRAME WITH DOUBLE DUCT OPENING

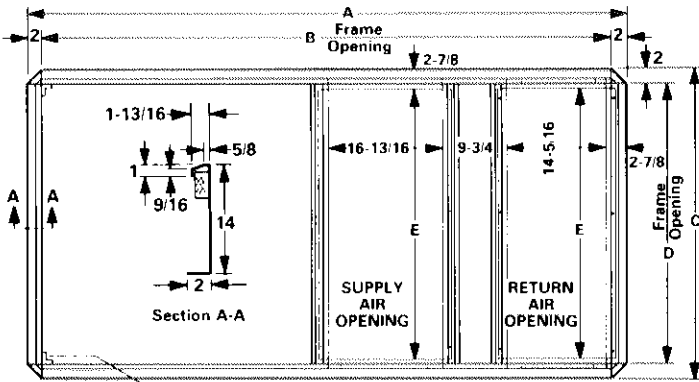

CORNER ANGLE
(4 furnished for frame assembly)

PLENUM SUPPORT ANGLE DETAIL

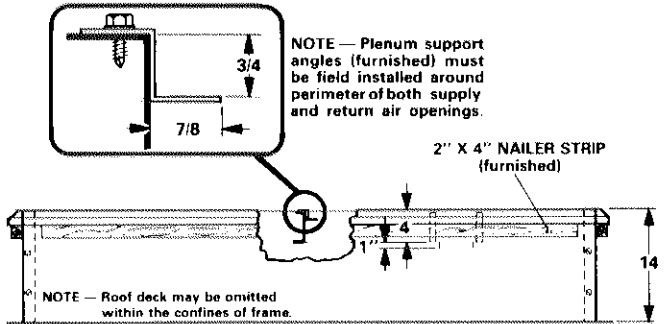

Model No.	A	B	C	D	E
RMF11-95	79-5/8	75-5/8	41-5/8	37-5/8	35-7/8
RMF11-135	85-1/8	81-1/8	59-5/8	55-5/8	53-7/8

RMF11 ROOF MOUNTING FRAME WITH FD11-95 & RTD11-95 CEILING SUPPLY AND RETURN

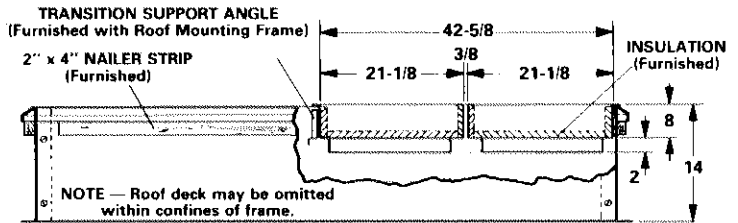
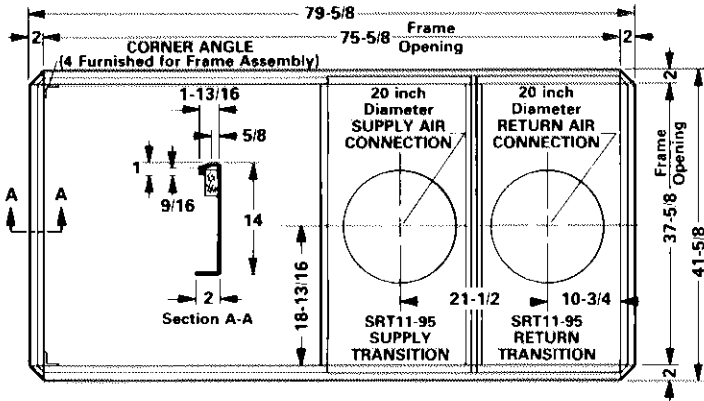

RMF11 ROOF MOUNTING FRAME WITH FD11-135 & RTD11-135 CEILING SUPPLY AND RETURN

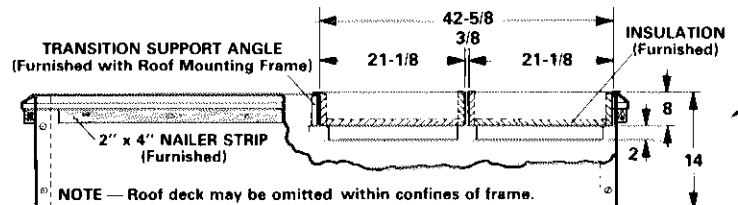
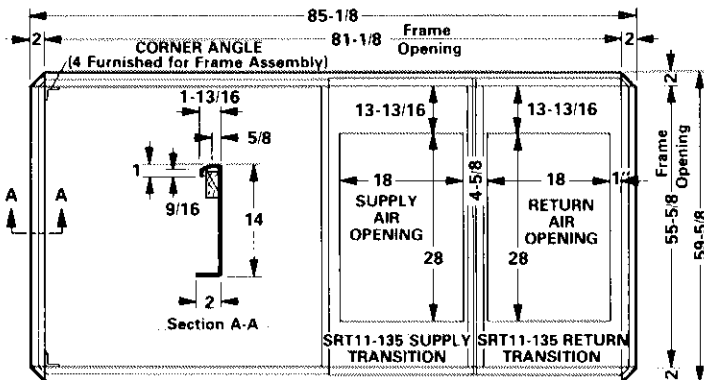

RMFH11 AND RMF11 FRAME MOUNTING DETAIL

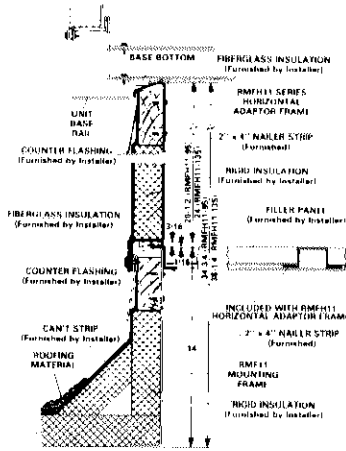

RMFH11 HORIZONTAL MOUNTING FRAME WITH RMF11 ROOF MOUNTING FRAME

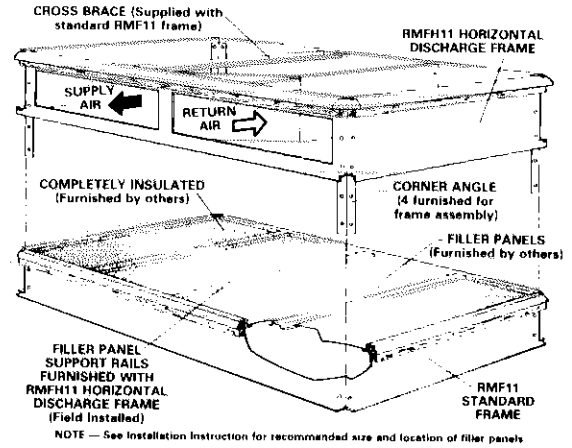

RMFH11 HORIZONTAL MOUNTING FRAME

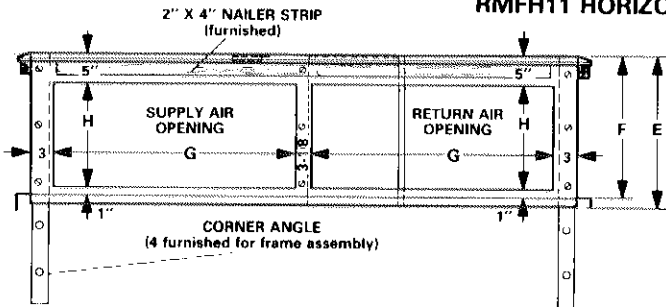

Model No.	A	B	C	D	E	F	G	H
RMFH11-95	79-5/8	75-5/8	41-5/8	37-5/8	22	20-1/2	33-1/4	14-1/2
RMFH11-135	85-5/8	81-5/8	59-5/8	55-5/8	25-1/2	24	36	18

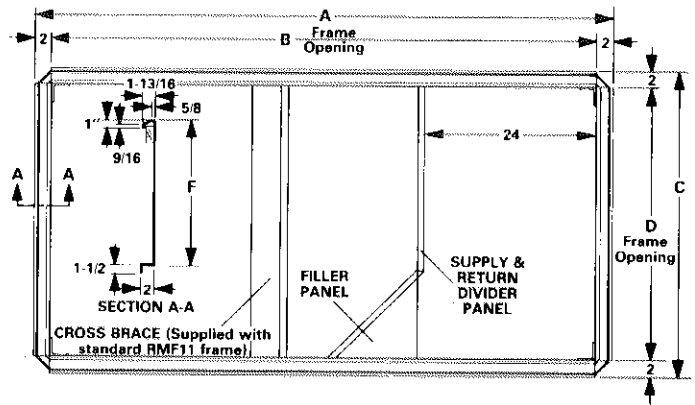

RMFA11 ADAPTOR MOUNTING FRAME WITH EXISTING RMF3 ROOF MOUNTING FRAME

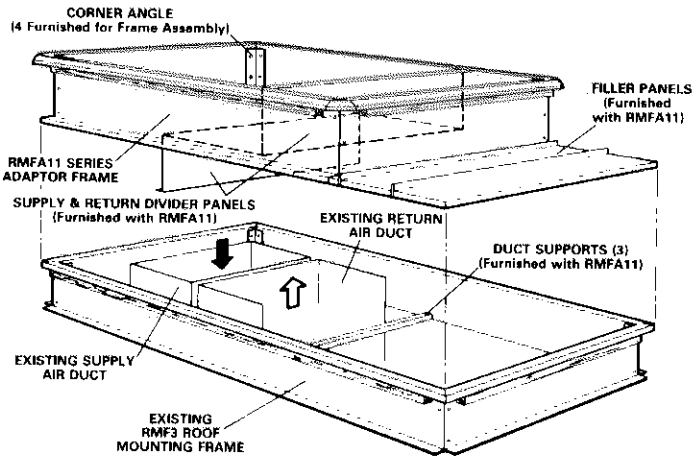

RMFA11 AND RMF3 FRAME MOUNTING DETAIL

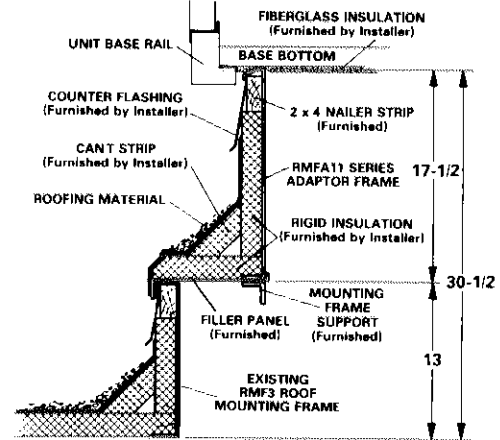

RMFA11 ADAPTOR MOUNTING FRAME

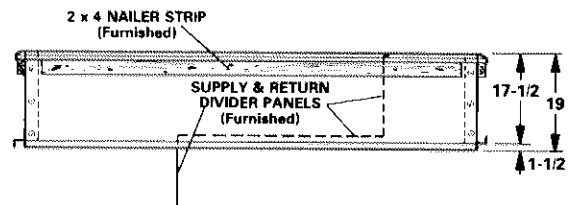
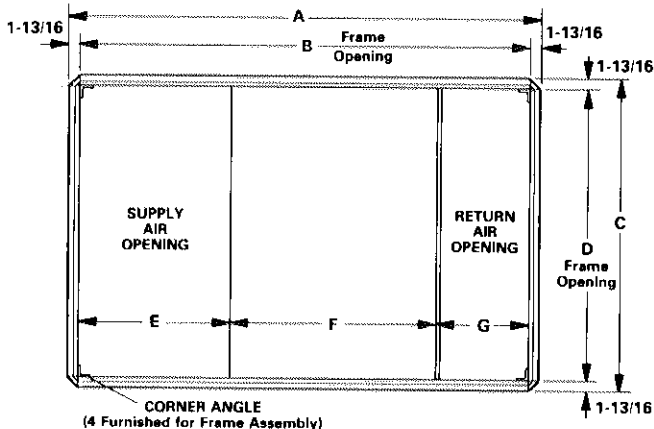

Model No.	A	B	C	D	E	F	G
RMFA11-95	79-1/4	75-5/8	41-1/4	37-5/8	23-1/4	28-3/8	24
RMFA11-135	84-3/4	81-1/8	59-1/4	55-5/8	29-7/8	33-1/8	18-1/8

AIR PATTERN

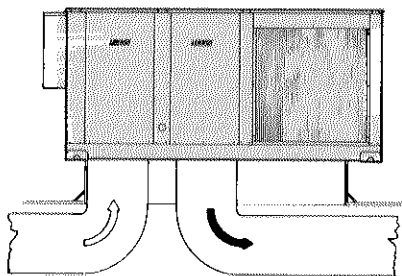

Separate Supply and Return (Double) Duct

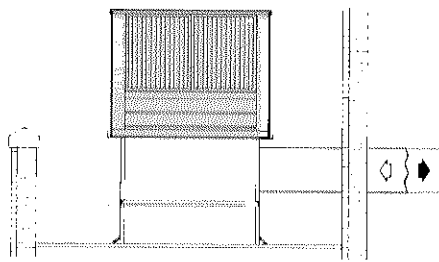

Horizontal Supply and Return Air
(Side by Side) Duct Application

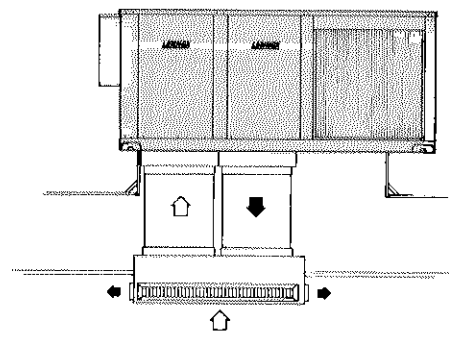

Combination Supply and Return Air
Ceiling Diffuser — Stepdown or Flush Grille

COMBINATION CEILING SUPPLY AND RETURN AIR DIFFUSERS

RTD11 STEP-DOWN

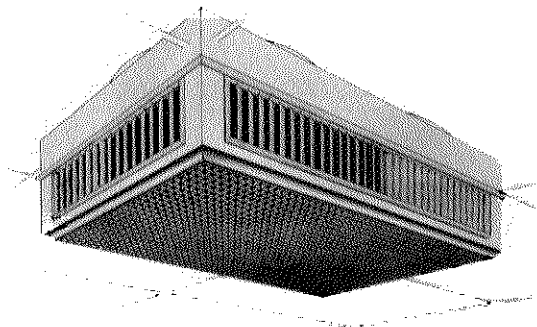

Optional RTD11 Combination Ceiling Supply and Return Diffuser Assembly — Step-down mount diffuser extends slightly below ceiling level and discharges conditioned air out through grilles on all four sides. Aluminum grilles are fitted with double deflection louvers for precise directional control of air flow. Return air enters through the large center grille. Assembly also includes insulated diffuser box with flanges for ease of duct connection, hanging rings for suspending, interior transition to insure low static and even air flow on all four sides. Transition is sealed internally to prevent recirculation. Diffuser assembly is completely factory assembled. Diffuser readily adapts to T-bar ceiling grids and plaster ceilings. RTD11-95 model diffuser is used with the CHA11-953 unit and RTD11-135 with the CHA11-135.

FD11 FLUSH

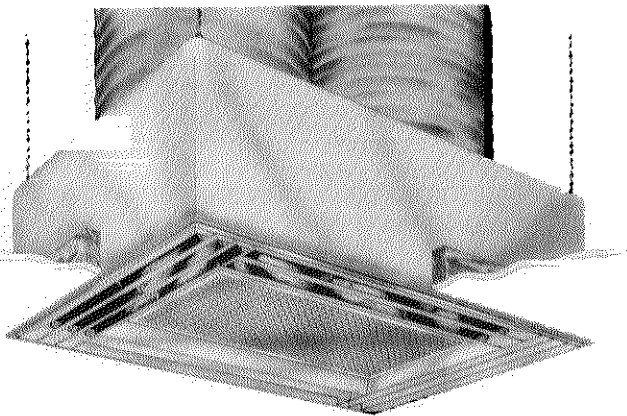

Optional FD11 Combination Ceiling Supply and Return Diffuser Assembly — Flush mount diffuser installs almost flush with the ceiling level and discharges conditioned air out through fixed blade louvers on all four sides. Fixed blade louvers insure that air flow will be evenly distributed. Return air enters through large center grille. Assembly also includes insulated diffuser box with flanges for ease of duct connections, support hanger eyelets at the top corners for secure installation, interior transition to insure low static and even air flow on all four sides. Transition is sealed internally to prevent recirculation. Diffuser assembly is completely factory assembled. Diffuser readily adapts to T-bar ceiling grids and plaster ceilings. FD11-95 model diffuser is used with the CHA11-953 unit and FD11-135 with the CHA11-1353.

Optional SRT11 Supply and Return Transitions — Transitions field install in the roof mounting frame and provide segregated and simple duct connections to supply and return diffuser. Completely insulated galvanized steel transitions have flanges for ease of duct connection. Duct from the transitions to the diffuser is not furnished and must be provided by installer. Transitions are completely factory assembled and easily field install in the roof mounting frame with minimum costs and labor requirement. SRT11-95 transitions are used with the RMF11-95 roof mounting frame and SRT11-135 with the RMF11-135 frame.

DIMENSIONS (inches)

**RTD11-95 STEP-DOWN
CEILING DIFFUSER**

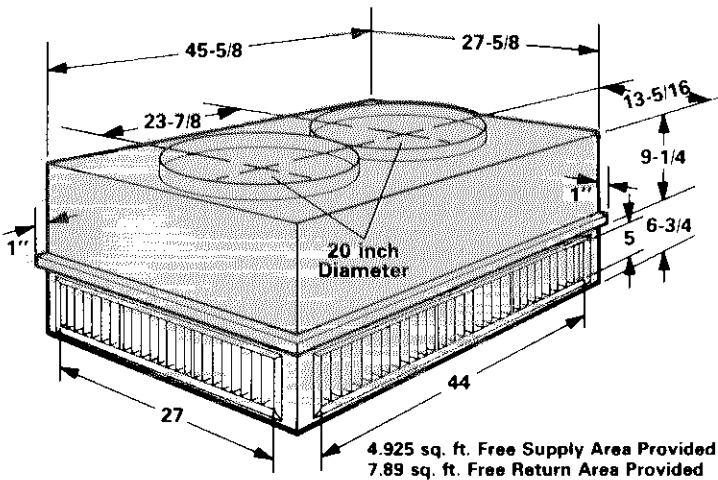

**FD11-95 FLUSH
CEILING DIFFUSER**

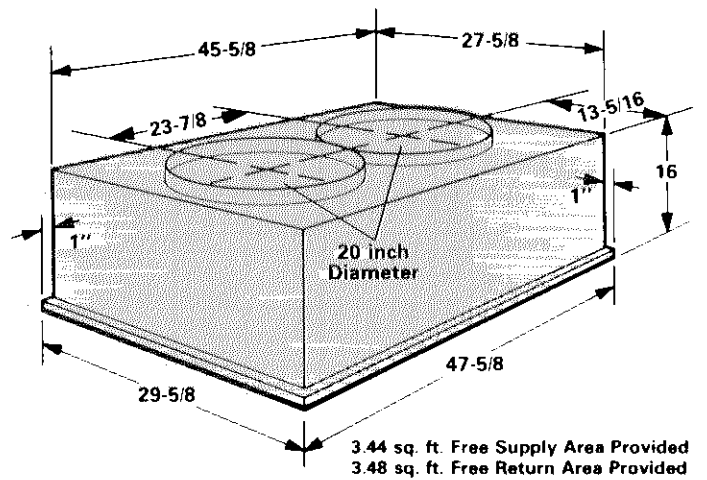

**RTD11-135 STEP-DOWN
CEILING DIFFUSER**

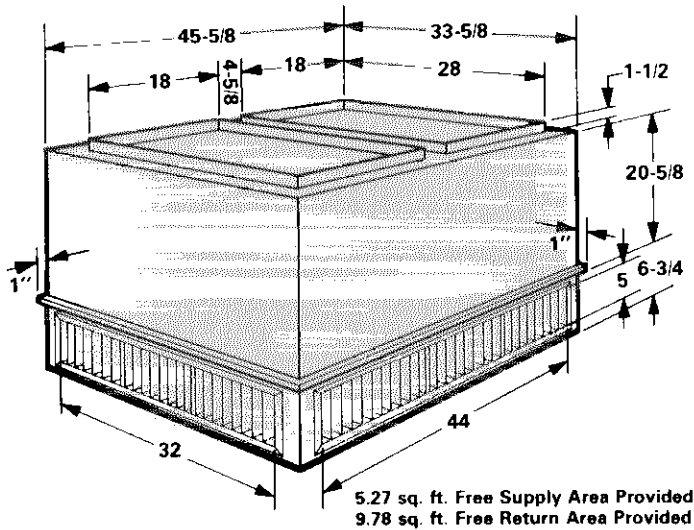

**FD11-135 FLUSH
CEILING DIFFUSER**

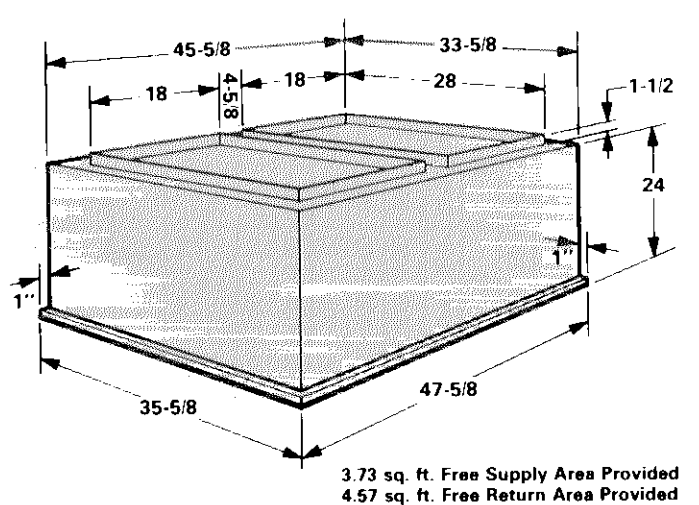

DIFFUSER AIR PATTERN

CHA11-953 With FD11-95 Flush Diffuser

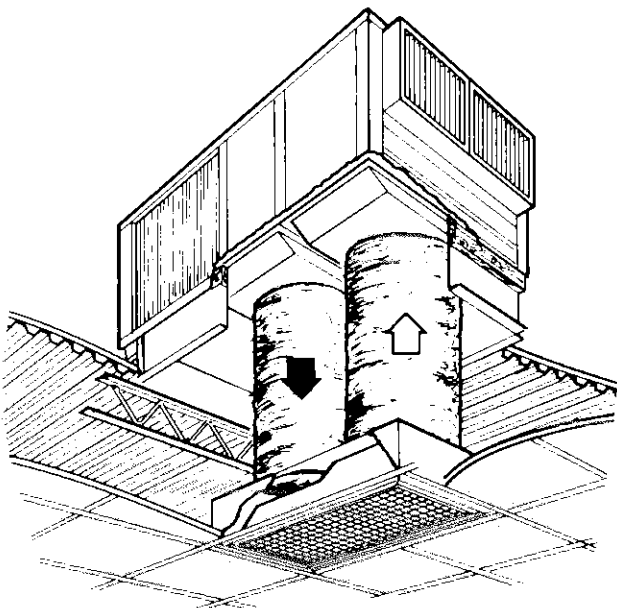

CHA11-1353 With FD11-135 Flush Diffuser

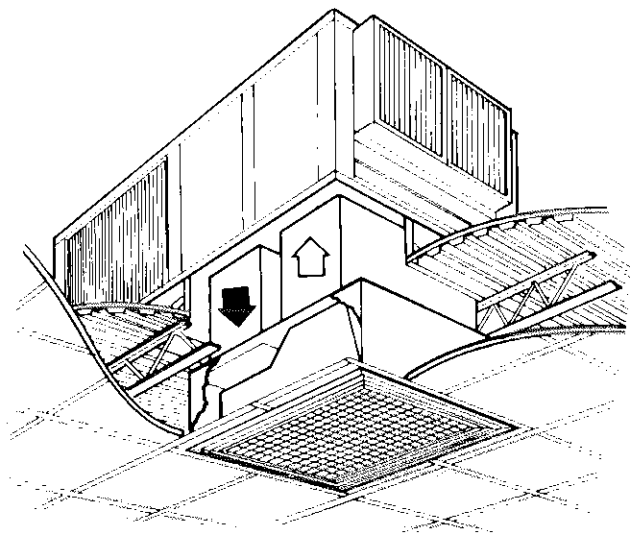

BLOWER DATA

CHA11-953 BLOWER PERFORMANCE

Air Volume (Cfm)	STATIC PRESSURE EXTERNAL TO UNIT — (Inches Water Gauge)															
	0	.10	.20	.30	.40	.50	.60	.70	.80	.90	1.00	1.10	1.20	1.30	1.40	1.50
	RPM BHP	RPM BHP	RPM BHP	RPM BHP	RPM BHP	RPM BHP	RPM BHP	RPM BHP	RPM BHP	RPM BHP	RPM BHP	RPM BHP	RPM BHP	RPM BHP	RPM BHP	RPM BHP
2600	600 .65	630 .75	670 .90	700 1.05	730 1.20	770 1.35	800 1.45	830 1.60	855 1.70	890 1.85	915 1.95	935 2.05	960 2.20	990 2.40	1020 2.60	1045 2.80
2800	630 .80	670 .95	705 1.10	735 1.25	775 1.40	810 1.55	835 1.70	860 1.80	895 1.95	920 2.10	945 2.20	965 2.35	990 2.50	1015 2.70	1040 2.90	1065 3.10
3000	670 1.00	705 1.15	740 1.35	775 1.50	810 1.65	840 1.80	870 1.95	905 2.10	930 2.30	950 2.40	975 2.55	995 2.70	1020 2.90	1040 3.05	1060 3.20	1080 3.40
3200	710 1.25	745 1.35	780 1.60	820 1.75	845 1.85	875 2.00	910 2.20	935 2.40	960 2.55	985 2.70	1010 2.90	1035 3.10	1055 3.25	1070 3.40	----	----
3400	750 1.50	785 1.65	825 1.85	855 2.05	885 2.20	920 2.35	945 2.55	970 2.75	995 2.90	1020 3.10	1050 3.25	----	----	----	----	----
3600	790 1.75	830 1.95	860 2.15	895 2.30	925 2.50	950 2.70	975 2.90	1010 3.10	1020 3.25	1050 3.40	----	----	----	----	----	----
3800	835 2.10	870 2.25	905 2.45	935 2.70	960 2.90	985 3.05	1020 3.30	1040 3.45	----	----	----	----	----	----	----	----

NOTE — All cfm data is measured external to the unit with the air filters in place.

BLOWER DATA

CHA11-1353 BLOWER PERFORMANCE

Air Volume (Cfm)	STATIC PRESSURE EXTERNAL TO UNIT — (Inches Water Gauge)															
	0	.10	.20	.30	.40	.50	.60	.70	.80	.90	1.00	1.10	1.20	1.30	1.40	1.50
	RPM BHP	RPM BHP	RPM BHP	RPM BHP	RPM BHP	RPM BHP	RPM BHP	RPM BHP	RPM BHP	RPM BHP	RPM BHP	RPM BHP	RPM BHP	RPM BHP	RPM BHP	RPM BHP
3500	450 .35	500 .55	550 .75	595 .90	630 1.10	665 1.25	700 1.35	730 1.40	760 1.50	790 1.65	820 1.75	835 1.80	865 1.9	895 2.00	915 2.15	945 2.30
3600	460 .40	510 .60	560 .85	605 1.00	640 1.15	670 1.35	710 1.40	735 1.50	770 1.65	800 1.75	825 1.85	850 2.00	880 2.10	910 2.30	935 2.45	960 2.60
3800	490 .60	530 .80	575 .95	625 1.15	655 1.30	685 1.40	720 1.55	755 1.70	780 1.85	810 1.95	840 2.10	865 2.25	895 2.40	925 2.60	950 2.75	975 2.90
4000	520 .75	560 .95	605 1.15	640 1.35	665 1.45	705 1.55	730 1.70	770 1.85	800 2.00	825 2.15	855 2.30	880 2.50	910 2.70	940 2.85	965 3.00	990 3.20
4200	545 .90	580 1.10	625 1.30	660 1.45	685 1.65	720 1.70	750 1.90	780 2.05	815 2.20	840 2.35	870 2.50	900 2.75	930 2.95	960 3.15	985 3.30	1010 3.40
4400	575 1.10	610 1.25	645 1.50	670 1.65	700 1.75	735 1.90	770 2.10	800 2.30	825 2.40	860 2.60	885 2.80	915 3.00	945 3.20	975 3.40	1000 3.55	1025 3.70
4600	600 1.25	635 1.50	670 1.70	685 1.80	720 1.95	755 2.15	780 2.30	815 2.45	840 2.65	875 2.85	905 3.05	930 3.25	960 3.45	990 3.65	1015 3.80	1040 4.00
4800	630 1.50	655 1.70	670 1.80	705 1.95	740 2.15	770 2.35	805 2.55	830 2.75	865 2.95	890 3.15	920 3.25	945 3.50	975 3.70	1005 3.90	1030 4.05	1055 4.20
5000	660 1.75	675 1.85	685 1.90	720 2.15	760 2.40	780 2.60	820 2.80	850 3.00	875 3.20	910 3.35	935 3.55	965 3.80	980 4.00	1015 4.15	1040 4.30	1065 4.50
5200	675 1.90	675 2.00	710 2.20	740 2.40	775 2.60	810 2.85	840 3.10	870 3.30	895 3.45	925 3.65	955 3.85	980 4.00	1005 4.20	1030 4.40	1055 4.55	1080 4.70
5400	675 2.10	690 2.20	730 2.40	765 2.60	790 2.85	825 3.15	860 3.40	880 3.55	915 3.75	940 3.95	975 4.30	1000 4.20	1025 4.40	1055 4.65	1070 4.80	----
5600	685 2.20	715 2.35	750 2.65	780 2.85	820 3.15	845 3.45	875 3.65	905 3.85	930 4.05	965 4.30	985 4.45	1015 4.55	1035 4.70	1055 4.90	1080 5.05	----

NOTE — All cfm data is measured external to the unit with the air filters in place.

BLOWER DRIVE SELECTION

Using total air volume (cfm) and system Static Pressure External to Unit (inches water gauge) requirements determine from Blower Performance Chart Rpm and Bhp required for job. Specify Bhp, exact Rpm and power characteristics required when ordering. The correct motor and pulleys will be factory installed. The following table lists Motor hp and Rpm range of drive setups available with each motor.

Model No.	Nominal Motor Hp	Maximum Usable Hp	*Rpm Range Of All Available Drive Setups @ 1720 Rpm Motor Speed
CHA11-953	1-1/2	1.725	805-1023
	3	3.45	805-1023 936-1197 (Electric Heat)
CHA11-1353	3	3.45	677-860
	5	5.75	896-1079

NOTE — Maximum usable hp of motors furnished by Lennox are shown in table. If other motors of comparable hp are used be sure to keep within the service factor limitations outlined on the motor name-plate. In Canada nominal horsepower is maximum usable horsepower.

*Specify exact Bhp, Rpm and power characteristics required when ordering.

CEILING DIFFUSER AIR THROW DATA

Model No.	Air Volume (cfm)	*Effective Throw Range (feet)			
		Step-Down		Flush	
		RTD11-95	RTD11-135	FD11-95	FD11-135
CHA11-953	3000	27 — 33	----	25 — 30	----
	3375	30 — 37	----	28 — 34	----
	3750	34 — 41	----	31 — 38	----
CHA11-1353	4400	----	34 — 42	----	32 — 40
	4950	----	38 — 47	----	36 — 45
	5500	----	43 — 52	----	40 — 50

*Throw is the horizontal or vertical distance an air stream travels on leaving the outlet of diffuser before the maximum velocity is reduced to 50 ft. per minute.

CHA11 ACCESSORY PRESSURE DROP

Model	Air Volume (cfm)	Power Saver	Total Pressure Drop (inches water gauge)								
			RTD Combination Supply and Return			FD Ceiling Supply & Return	2 Row Hot Water Coil	Electric Heater			
			2 Sides Open	3 Sides Open	4 Sides Open			15 kW	30 kW	45 kW	60 kW
CHA11-953	2600	.023	.24	.21	.18	.17	.36	.08	.23	.39	.58
	2800	.025	.27	.24	.21	.20	.40	.09	.25	.44	.64
	3000	.035	.32	.29	.25	.25	.44	.10	.28	.49	.70
	3200	.045	.41	.37	.32	.31	.48	.11	.31	.54	.77
	3400	.055	.50	.45	.39	.37	.52	.12	.33	.58	.84
	3600	.065	.61	.54	.48	.44	.56	.13	.35	.63	.89
	3800	.075	.73	.63	.55	.51	.60	.14	.38	.68	.94
CHA11-1353	3800	.029	.40	.32	.26	.18	.37	.14	.26	.45	.62
	4000	.037	.44	.36	.29	.21	.39	.15	.28	.50	.69
	4200	.044	.49	.40	.33	.24	.41	.16	.30	.54	.76
	4400	.052	.54	.44	.37	.27	.45	.18	.33	.59	.82
	4600	.059	.60	.49	.42	.31	.48	.20	.36	.64	.89
	4800	.067	.65	.53	.46	.35	.51	.22	.39	.68	.95
	5000	.074	.69	.58	.50	.39	.54	.24	.41	.72	1.02
	5200	.082	.75	.62	.54	.43	.56	.25	.44	.77	1.09
	5400	.090	.80	.68	.59	.48	.59	.26	.47	.82	1.15
5600	.097	.86	.72	.63	.52	.62	.28	.50	.86	1.22	

CONTROL SELECTION FLOW CHART

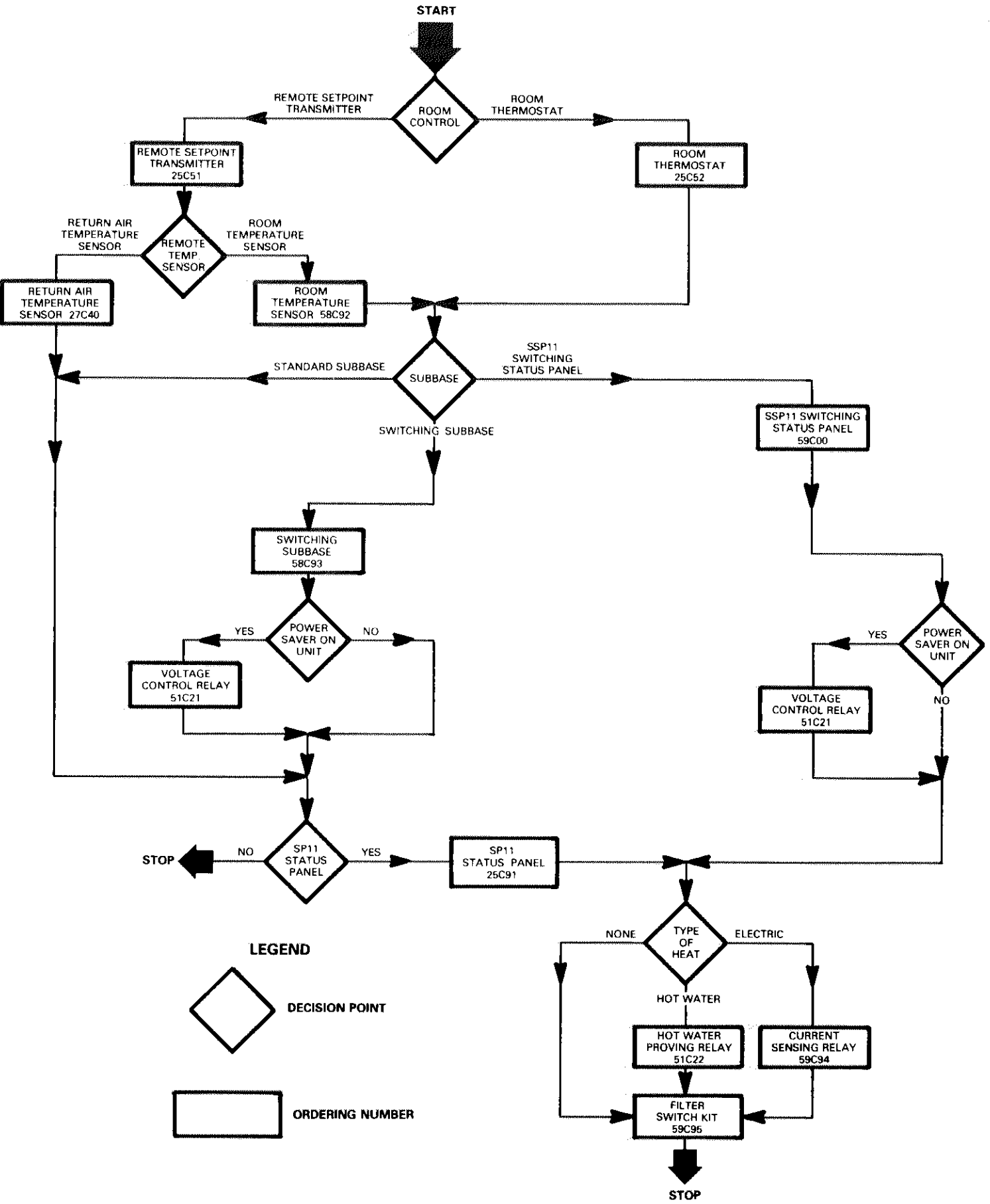

LEGEND

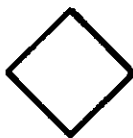

DECISION POINT



ORDERING NUMBER

GUIDE SPECIFICATIONS

Prepared for the guidance of architects, consulting engineers and mechanical contractors.

General — Furnish and install a single package air to air DX mechanical cooling system complete with automatic controls. The single package unit shall be a standard product of a firm regularly engaged in the manufacture of heating-cooling equipment. The manufacturer shall have parts and service available throughout the United States and Canada.

The installed weight shall not be more than lbs. Entire unit shall have a width of not more than inches, a depth of not more than inches and an overall height of not more than inches. The equipment shall be shipped completely factory assembled, precharged, piped and wired internally ready for field connections. In addition, manufacturer shall test operate system at the factory before shipment.

Approvals — Single package unit shall be U.L. Listed. All wiring shall be in compliance with NEC and CEC.

Roof Mounting Frame — Furnish and install a steel roof mounting frame for bottom or horizontal discharge and return air duct connection. It shall mate to the bottom perimeter of the equipment. When flashed into the roof it shall make a unit mounting curb and provide weatherproof duct connection and entry into the conditioned area. Flashing shall be the responsibility of a roofing contractor. 14 inch high frame shall be approved by National Roofing Contractors Association.

Air Distribution — Equipment shall be capable of bottom or side handling of conditioned air. All air distribution ducts shall be fiberglass or ga. galvanized steel insulated with inch thick lb. density fiberglass or equivalent.

Furnish and install a (flush or stepdown) optional combination ceiling supply and return air grille. It shall be capable of not less than ft. radius of effective throw.

Cooling System — The total certified cooling capacity shall not be less than Btuh with an evaporator air volume of cfm, an entering wet bulb air temperature of F, an entering dry bulb air temperature of F and a condenser entering temperature of F. The compressor power input shall not exceed kw at these conditions.

The coils shall be non-ferrous construction with aluminum fins mechanically bonded to durable copper tubes. Coils shall be pressure leak tested. Coil face area shall be not less than sq. ft. (evaporator) and sq. ft. (condenser).

The compressor shall be resiliently mounted, have overload protection, internal pressure relief and crankcase heater. The refrigeration system shall have suction and discharge line service gauge ports, high pressure switch, low pressure switch, driers and full refrigerant charge. Control option available shall consist of low ambient control. Shall comply with ARI Standard 210 Test Conditions.

Additive Electric Heaters — The certified total heating capacity output shall be Btuh with kw input at volts power supply.

Optional electric heaters shall be available. Heating elements shall be nichrome bare wired exposed directly to the air stream. Time delays shall bring the elements on and off in sequence with a time delay between each element. Limit controls shall provide overload and short circuit protection.

Hot Water Heater — The certified total heating capacity output shall be Btuh with a heating coil air volume of cfm, at water entering temperature of F and a flow rate of gpm and an entering air temperature of F. A three way modulating water valve shall be available. The coil shall be of non-ferrous construction with aluminum fins mechanically bonded to copper tubes. Factory installed freeze-stat shall provide freeze-up protection. Coil shall be factory pressure leak tested.

Electronic Control System — Shall provide room thermostat, discharge temperature sensor, logic panel, modulating damper actuator and related accessories to automatically operate the mechanical equipment through the heating or cooling and ventilating cycles as required.

Cabinet — Shall be galvanized steel with a baked-on outdoor enamel paint finish. Cabinet panels where conditioned air is handled shall be fully insulated to prevent sweating and minimize sound. Openings shall be provided for power connection entry. Base shall have drainage holes. Lifting lugs shall be provided for rigging.

Service Access — All components, wiring and inspection areas shall be completely accessible through removable panels.

Supply Air Blower — Centrifugal supply air blower shall have permanently lubricated ball bearings, adjustable belt drive and motor mount where belt tension can be easily adjusted. The entire assembly shall be floated on resilient rubber mounts. Blower wheel shall be statically and dynamically balanced. Blower shall be capable of delivering cfm at an external static pressure of inches water gauge requiring bhp and rpm.

Condenser Fans — Twin propeller type condenser fans shall discharge vertically and be direct driven by a hp motor. Fan motor shall be totally enclosed with sleeve bearings, permanently lubricated, inherently protected and equipped with rain shield. Fan shall have a safety guard.

Air Filters — 1" thick disposable frame type fiberglass media filters shall have not less than sq. ft. of free area.

POWER SAVER — Furnish and install complete with controls an optional mechanically linked air mixing damper assembly including outdoor air and recirculated air dampers. The assembly shall mount within the confines of the unit cabinet and provide for the introduction of outside air for minimum ventilation and free cooling. Outdoor air hood shall mount external to the unit cabinet. Damper motor shall be 24 volt, modulating spring return. Controls shall include discharge sensor and adjustable enthalpy control.

Fresh Air Dampers — Optional equipment shall be available to control outdoor air requirements. Outdoor air damper assembly shall be available for manual or automatic operation. Dampers shall be adjustable for air quantities of 0 to 100%. Shall include externally mounted outdoor air hood.

Exhaust Air Dampers — Pressure operated dampers shall install within the unit. Damper blades shall ride in nylon bearings and be gasketed for tight seal and quiet operation.

Remote Status Panel — Shall be available for installation within the conditioned area to observe equipment operation. The panel shall include signal lights for Cool Mode, Heat Mode, Compressor 1, Compressor 2, No Heat and Filter.

Remote Switching Status Panel — Shall be available for installation within the conditioned area to control and observe equipment operation. The panel shall include signal lights for Cool Mode, Heat Mode, Compressor 1, Compressor 2, No Heat and Filter. System selector switch and fan switch shall provide operational mode and blower operation. After hours timer switch shall override night setback controls and provide normal operation for time period set.

Night Setback Controls — Complete controls shall be available to program the equipment for day-night operation.

Blower Powered Mixing Damper Boxes — Shall be available for zone control system applications. Furnish and install complete with controls an air mixing blower powered unit including conditioned air dampers, recirculated air dampers and direct drive blower(s). Capable of delivering Cfm at an external static pressure of inches water gauge. The blower powered unit shall install in the duct system within the structure.

CHA11-953 (HWC11-95) HOT WATER HEATING CAPACITY

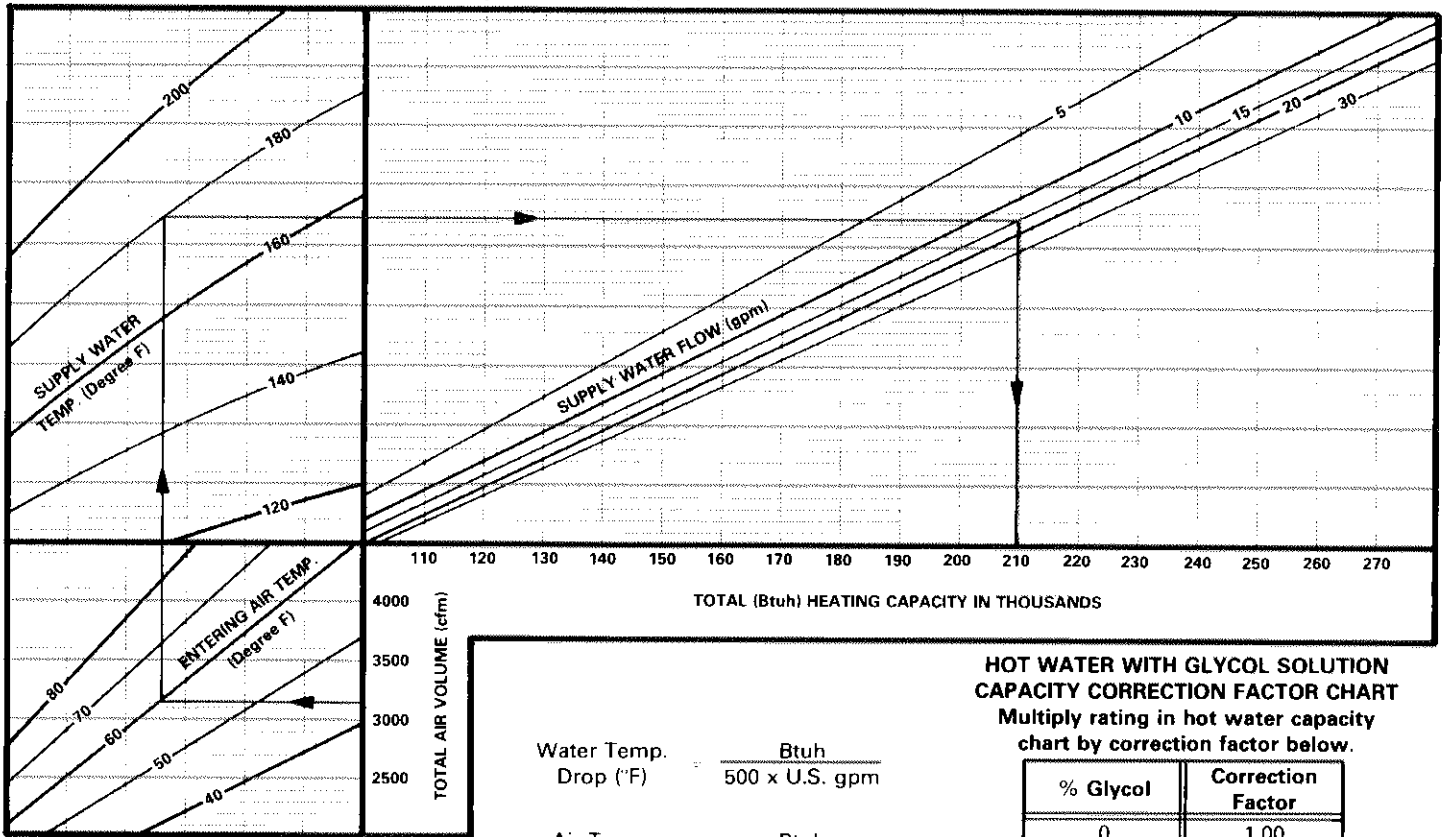

**HOT WATER WITH GLYCOL SOLUTION
CAPACITY CORRECTION FACTOR CHART**
Multiply rating in hot water capacity chart by correction factor below.

% Glycol	Correction Factor
0	1.00
10	.97
20	.94
30	.91
40	.87
50	.84

CHA11-1353 (HWC11-135) HOT WATER HEATING CAPACITY

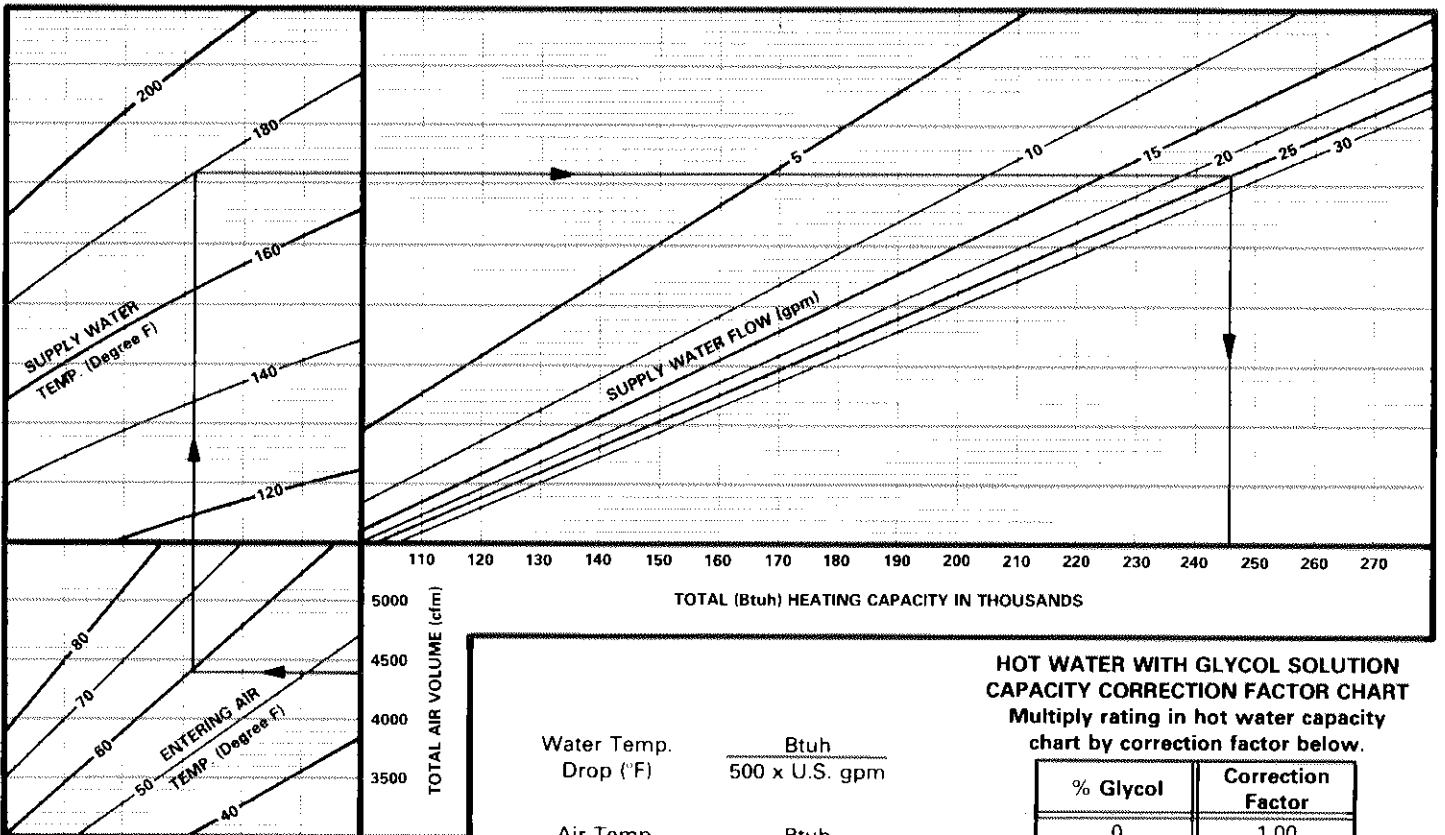

**HOT WATER WITH GLYCOL SOLUTION
CAPACITY CORRECTION FACTOR CHART**
Multiply rating in hot water capacity chart by correction factor below.

% Glycol	Correction Factor
0	1.00
10	.97
20	.94
30	.91
40	.87
50	.84

CHA11-953-1353 HOT WATER COIL PRESSURE DROP

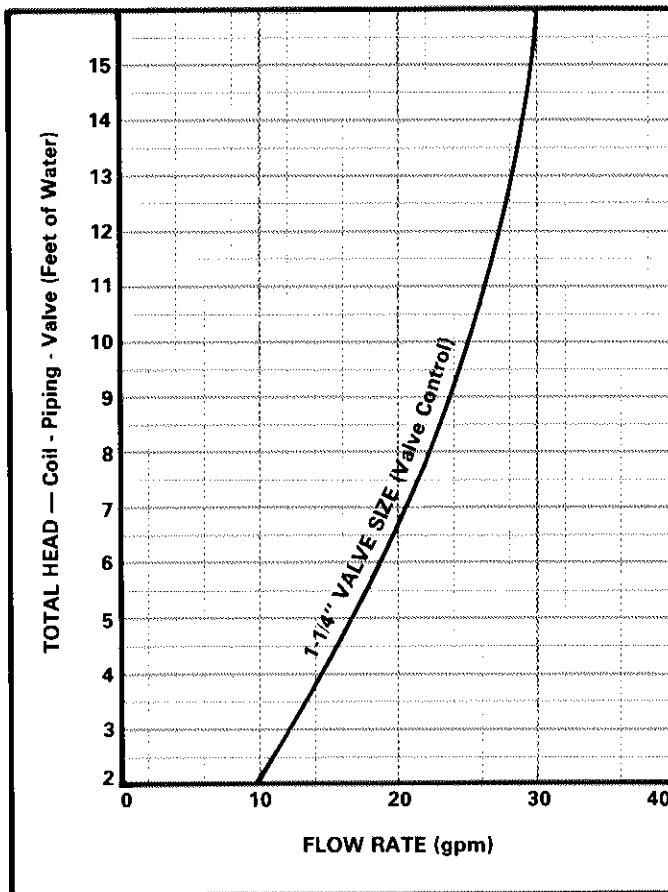

HOT WATER WITH GLYCOL SOLUTION PRESSURE DROP CORRECTION FACTOR CHART

Multiply figure in pressure drop chart by
correction factor below.

% Glycol	Correction Factor
0	1.00
10	1.07
20	1.14
30	1.22
40	1.31
50	1.40

MODULATING VALVE CONTROL SYSTEM PIPING

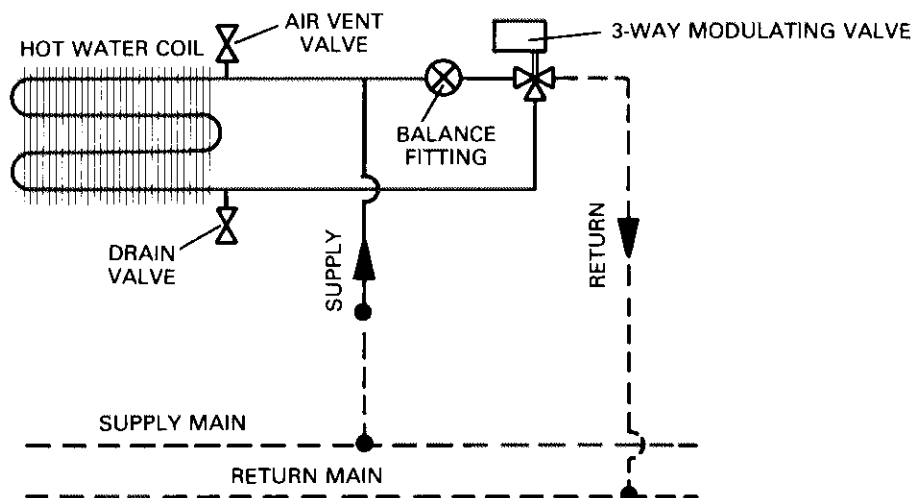

———— PIPING AND CONTROLS FURNISHED
AND FACTORY INSTALLED

- - - - - PIPING FURNISHED BY INSTALLER