



DIRECT MULTIZONE SYSTEM DMS3-415—DMS3-600

Rooftop Heating-Cooling-Ventilating with Multizone Control

Gas Heat-850,000 Btuh Max. — Electric Heat-512,000 Btuh Max.

Hot Water 1,000,000 Btuh Max.—Steam Heat 1,110,000 Btuh Max.

Chilled Water Cooling-700,000 Btuh Max.

DX Cooling—406,000 & 518,000 Btuh @ ARI CONDITIONS—Air Volume—18,000 cfm Max.

- Outdoor Enameled Galvanized Steel Casing
- Heat-Cool-Vent in One Single Package
- Factory Assembled, Piped and Wired
- Extruded Aluminum Base Frame
- Many Options Available
- Power Supply Choice

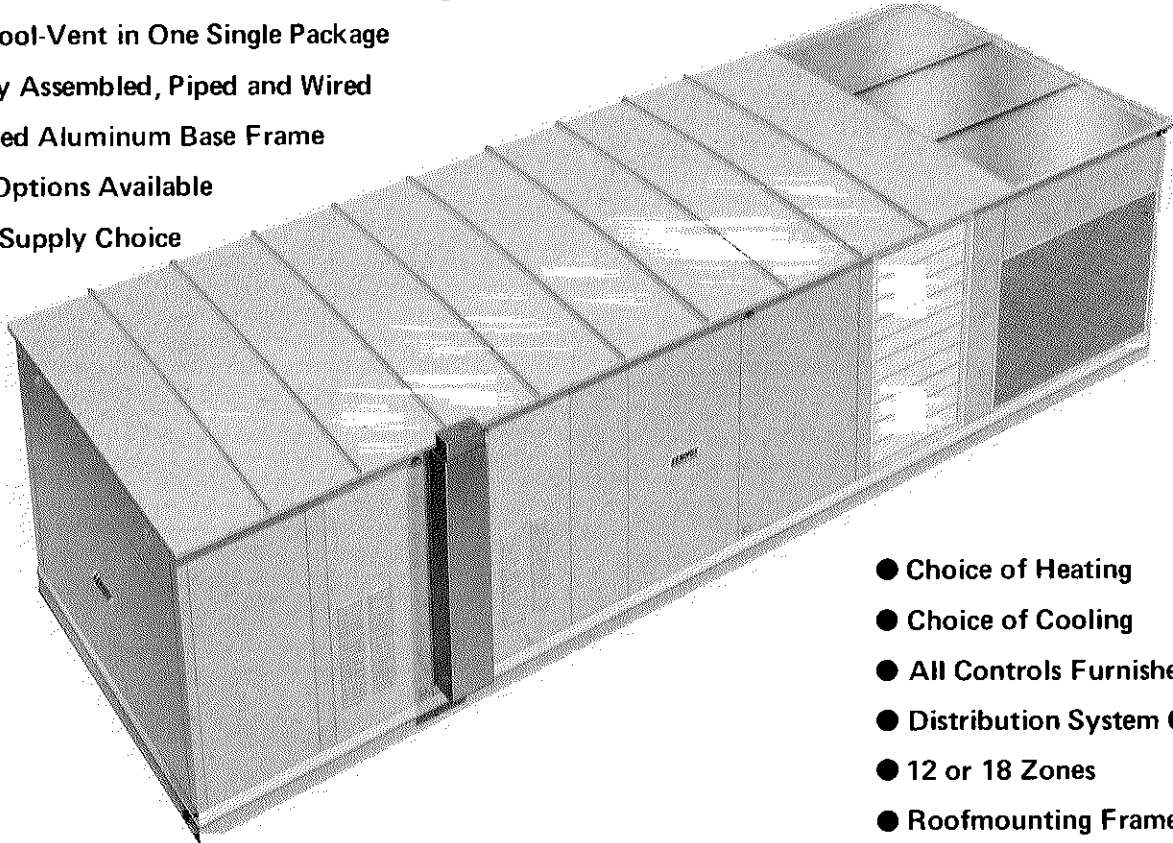

- Choice of Heating
- Choice of Cooling
- All Controls Furnished
- Distribution System Choice
- 12 or 18 Zones
- Roofmounting Frame Furnished

Direct Multizone System Offers Many Options, Economical Operation And Single Source For Comfort Responsibility

The DMS3 Rooftop Direct Multizone System is a complete Heat-Vent-Cool assembly (including condensing unit) of highly engineered, integrated components in a weatherproof, low silhouette single package. All necessary controls including a disconnect are factory installed wired and approved by appropriate approval agencies.

Units are available with a choice of options including: gas, electric, hot water or steam heat and chilled water cooling or self contained DX air conditioning with a complete refrigerant charge, POWER SAVER™, fresh air control, twin supply air blowers, drive and motor selection, return air blower, indoor condenser heat and choice of air filtering. Complete controls are also furnished. Units are also available as cooling-ventilating models only, less the heating components. Air distribution is 12 or 18 zone multizone control at the unit or double duct with independent mixing dampers at each zone. A rugged roof mounting frame is furnished. A choice of two deck control systems is available: Solid State Lennox Energy Saving Control System or Load Sensor Master/Sub-Master System.

The DMS3 units make it possible to specify an entire rooftop multizone comfort system, including all equipment and controls, from one manufacturing source. This permits dealing

only with Lennox for complete service and parts on the entire system. Lennox is and wants to be totally responsible for all the equipment and also for all of the controls operation when furnished as part of the package by Lennox.

The DX cooling system consists of three separate and completely independent refrigeration systems including separate Lennox LANDMARK™ compressors and their independent condenser with fans and a separate circuit in the single evaporator coil. If cooling is not required initially the unit is available without the evaporator coil, compressors and condensing unit section. Future add-on cooling may be accomplished two ways. The evaporator coil can be factory installed with a standard production remote condensing unit and controls installed at a later date or the evaporator coil, controls and a remote condensing unit can all be installed later when cooling is required.

Equipment is shipped factory assembled. Factory installed disconnect and control wiring terminal block permit quick field wiring connections. Cooling system has been thoroughly tested and rated according to ARI Standard 210 test conditions. Life cycle testing of the heat exchanger in the Lennox Laboratory proves long life of the heating element. In addition each unit is test operated at the factory before shipment.

NOTE—Specifications ratings and dimensions subject to change without notice.

SPECIFICATIONS AND RATINGS

Model No.		DMS3-415	DMS3-600	
DX Cooling Capacity	At ARI Standard 210 Test Conditions	Total capacity (Btuh)	406,000	
		S/T ratio	.74	
		Compressor watts	40,500	
Condenser Coils	Net face area (sq. ft.)	(3)-11.7	(3)-11.7 & (1)-9.4	
	Tube diameter—No. of rows—Fins per inch	3/8-4-18	3/8-4-18 & 3/8-5-15	
Condenser Fans	Diameter (in.) & No. of blades	(3)26-5	(4)26-5	
	Total air volume (cfm)	20,000	25,000	
	Motor hp	(3)-1	(4)-1	
	Watts input (total)	4230	5640	
Supply Air Blowers	Blower wheel nominal diam. x width (in.)	(2) 18 x 18		
	Motor horsepower (minimum—maximum)	5-15		
	Air volume range (cfm)	9,000-18,000		
Evaporator Coil	Net face area (sq. ft.)	33.8		
	Tube diameter—No. of rows—Fins per inch	1/2-4-13		
Chilled water cooling capacity range (Btuh)		200,000/700,000		
4 Row Chilled Water Coil	Net face area (sq. ft.)	27.0		
	Tube diameter—No. of rows—Fins per inch	1/2-4-13		
6 Row Chilled Water Coil	Net face area (sq. ft.)	26.2		
	Tube diameter—No. of rows—Fins per inch	1/2-6-10		
Heating Options	Gas piping Connections IPS (in.)	Natural and Propane Propane (350,000 Btuh Input Only)	1-1/4 1	
	Gas heating capacities (Nat. or Propane) Maximum input/output (Btuh)		*350,000/262,500 *500,000/375,000 **700,000/525,000 **850,000/637,500	
	†Electric Heating capacity range (Btuh)	4 elements	153,500/204,600	
		5 elements	191,800/255,800	
		6 elements	230,200/306,900	
		7 elements	268,500/358,000	
		8 elements	306,900/409,200	
		9 elements	345,300/460,400	
	Hot water heating capacity range (Btuh)		300,000/1,000,000	
	Steam heating capacity range (Btuh)		400,000/1,110,000	
Hot Water Coil	Net face area (sq. ft.)	14.3		
	Tube diameter—No. of rows—Fins per inch	1/2-4-10		
Steam Coil	Net face area (sq. ft.)	15.0		
	Tube diameter—No. of rows—Fins per inch	1/2-2-10		
Hot Water, Steam & Chilled water coil connection (Inlet & Outlet)		See Valve Selection Curves		
Filter Options	Standard frame filter size (in.) & free area (sq. ft.)	(6)-20 x 20 x 1-(6)-20 x 25 x 1-(33.5)		
	Roll filter free area (sq. ft.)	23.3		
	Bag filter free area (sq. ft.)	848.8		
Return Air Blower	Wheel diameter (in.)	40-backward curve blades		
	Motor horsepower (minimum—maximum)	1-1/2-††7-1/2		
	Air volume range (cfm)	5,000-18,000		
Condensate drain connection I.P.M. (in.)		1-1/4		
Electrical characteristics		208 to 600 volt-60 hertz-3 phase		

*Two stage heating natural gas only.

**Dual heat exchangers in series.

†See electric heat rating table for capacities at various voltages.

††Standard DMS3-600. Optional DMS3-415.

NOTE--Hot water and chilled water capacity ranges shown are possible with varying supply conditions and air volumes. See coil capacity curves. Steam capacity ranges are possible with varying steam pressure and air volume. See steam rating chart.

MANY OPTIONS AND FEATURES IN A FLEXIBLE SINGLE PACKAGE ROOFTOP DIRECT MULTIZONE SYSTEM

ELECTRONIC LENNOX ENERGY SAVING SYSTEM (Opt.)

The solid state electronic control system measures the deviation between room temperature and set point and then controls the supply air temperature to meet the load requirements. The control system consists of a room temperature sensing transmitter (thermostat) for each zone, supply air sensor for each zone, load analyzer control module with zone circuit board and heat-cool logic control relays, spring return zone damper actuator for each zone plus a mixed air/ventilation damper actuator with infinite resolution for blending outdoor air with return air. This system operates the unit equipment to automatically match its output to the load requirements with minimum space temperature variation. To accomplish this, the zone with the greatest cooling load will have its zone damper open full to the cold deck and will control the cold deck temperature to just match the load requirement in that zone. The zone with the greatest heating load will have its zone damper open full to the hot deck and will control the hot deck temperature to just match the load requirement in that zone. The other zones in the system (with their individual room temperature sensing transmitters and supply air sensors) will blend hot and cold air to match the supply air temperature to the load in each individual zone. Also the system will often balance so that the same supply air temperature will be nearly right for each zone. The system can then "coast" with only the blowers operating for as long as the balanced condition continues. Should the load requirement in any zone change the controls will immediately respond to match supply air temperature to the load in that zone. In addition, the right amount of outdoor air or indoor condenser coil heat is automatically furnished and utilized in the system to maintain temperature and minimize mechanical heating and cooling. With this control system troubleshooting is simple because the load analyzer signal transmitted by the room sensing transmitter reflects the load on the zone and indicates system performance. The load analyzer signal can be monitored at the room temperature sensing transmitter or the load analyzer control module mounted on the unit. All zones of the system may be checked at one easily accessible point, the load analyzer control module.

POWER SAVER SOLID STATE CONTROLS (Opt.)

Optional equipment controls fresh air entry and "Free Cooling" with outdoor air. Structures that have high internal gains quite often require cooling at low outdoor air temperature. Lennox POWER SAVER eliminates the need for mechanical cooling at these temperatures by using outdoor air for cooling. Mixed air low limit control located in the blower section, morning warm-up control located in return air stream and enthalpy control located in the outdoor air stream, regulate damper operation. The enthalpy control senses the total heat content of the outdoor air. This unique control prevents excessive moisture laden outdoor air that will add to the cooling load from entering the unit and yet permits cool dry air capable of cooling to enter, thus taking full advantage of free outdoor air for cooling. The POWER SAVER equipment may also be specified less controls with the dampers linked for manual operation.

SOLID STATE ZONE CONTROL SYSTEM (Opt.)

Factory installed damper motor choice:

Control System Damper Motor

ZC14 Modulating (spring return)

ZC12 Pneumatic Actuator

(See Pneumatic Controls bulletin, Page 75)

● CONTROL OPTIONS

Night Setback—Equipment is wired to receive night setback controls. In mild climates a manual system switch (not furnished), or automatic programming turns off the entire unit. For colder climates a "night thermostat" located in an average zone controls the conditioned area to a preset fuel saving temperature. Manual (BM-4762) or 12 hour clock timer (BM-4761) kits are available to override existing night setback controls. The switch or timer is mounted on a stainless steel plate which fits two standard electrical outlet boxes located in the wall. An optional skip day clock timer (P-8-3744) mounted in the DMS3 programs the equipment and is required when the 12 hour clock timer (BM-4761) night override kit is used.

Remote Readout Panel—From one centrally located spot within the structure the operation of the DMS can be checked at a glance. Signal lights indicate; System On, Combustion Lockout, Condensing Unit Inoperative and Dirty Filter. See bulletin (Page 71) in Accessories section. When panel is used for nite setback operation the following controls must be ordered extra; nite thermostat, subbase, adaptor plate and skip-day clock.

● SUPPLY SYSTEM CHOICE

12 or 18 Zones—Located at the unit with assembly matching width of the unit. Zone dampers can be mechanically linked to be driven by a single damper motor. 6 zones per motor maximum. 800 series motors can also be slaved and controlled by a single thermostat.

Balancing Dampers—Furnished and located at each zone outlet in unit.

Double Duct—Discharge head is located within the unit. Hot and cold ducts run length of building with branch lines feeding mixing boxes in each zone. A choice of mixing boxes is available. See mixing box bulletin (Page 73) in this section.

Dual Duct Splitter—A combination zone and double duct system application is also available. The duct system supply air outlets, in the unit, may be factory arranged in almost any combination desired.

● LOAD SENSOR MASTER/SUB-MASTER DECK CONTROLS (Opt.)

Keeps the hot and cold deck temperatures at a conservative setting during periods when all zones are satisfied. The hot deck (outside reset 1 to 1) temperature controller has an adjustable range and is factory set at 75F. The cold deck (outside reset 4-1) temperature controller is factory set at 70F and also has an adjustable range. Whenever any zone requires maximum heat or cooling the Load Sensor shifts the conservatively set deck temperature controls to satisfy the increased demand. When all zones are satisfied the Load Sensor shifts the deck temperature back to the conservative power saving temperature. Mixing boxes must be applied to double duct applications. A minimum number of mixing boxes will require Load Sensors (optional), located in the most critical zones, in most applications to sense temperature requirements.

● LOAD SENSOR ZONE CONTROL SYSTEM (Opt.)

Factory installed damper motor choice:
Control System Damper Motor
ZC8 800 Series Proportioning
ZC8S... 800 Series Proportioning (slave damper)

● ROOF MOUNTING FRAME

A rugged 14" National Roofing Contractors Association approved roof mounting frame (MF3-31614) exactly fits the perimeter of the DMS unit. It is flashed into the roof and mates to the DMS3 extruded aluminum base where a neoprene sponge gasket completes the sealing and weatherproofing job. A 2 x 4 nailer is secured to the sides of the frame to facilitate flashing. It is also available 8" high (MF3-3168) (not NRCA approved).

● UNITIZED FRAME AND BASE

Base frame is constructed of 6061-T6 extruded aluminum. All support members are 16 gauge galvanized steel. The entire bottom is a galvanized drain pan which traps and drains off moisture.

● COMBUSTIBLE ADAPTOR FRAME (Opt.)

The AF6-415 adaptor frame is used when the MF3 roof mounting frame is installed on combustible material. The adaptor frame isolates the warm air plenum from combustible material.

● APPROVALS

Gas model is A.G.A. certified or C.G.A. approved. Hot water, electric heat models and cooling models are U.L. Listed. DMS3-600 U.L. Listing pending. All electrical components are U.L. Listed. Wiring is according to NEC or CEC. F.I.A. and F.M. construction is available.

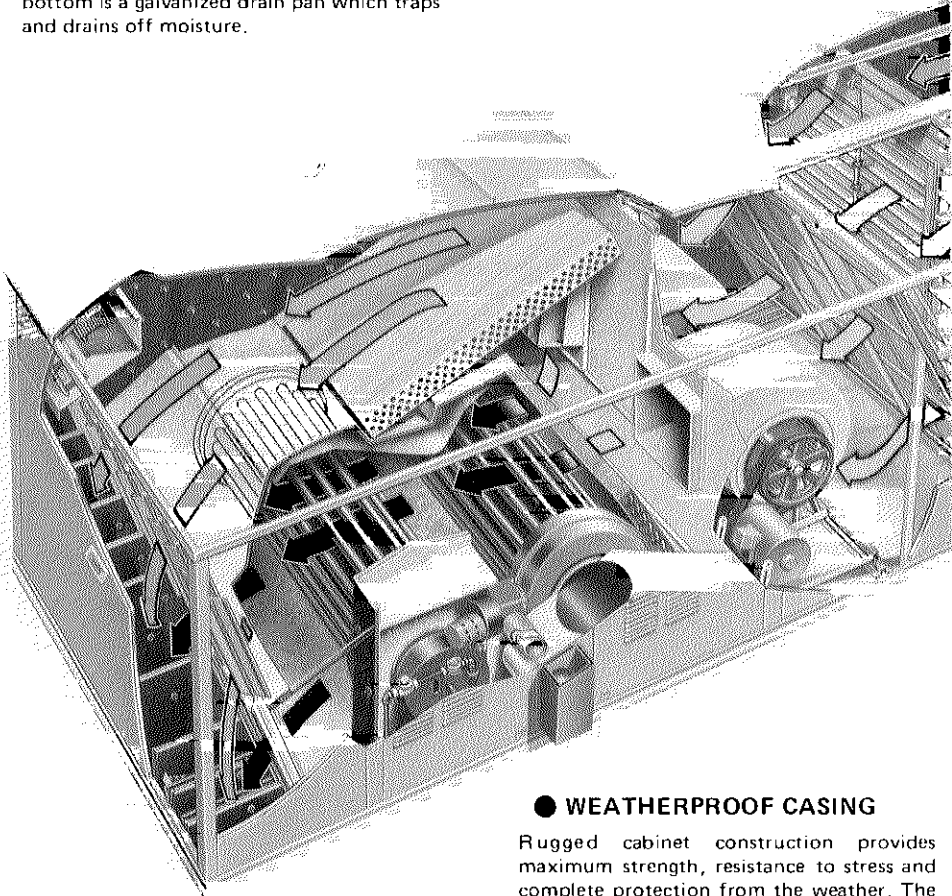

● WEATHERPROOF CASING

Rugged cabinet construction provides maximum strength, resistance to stress and complete protection from the weather. The top and side panels are constructed of heavy gauge galvanized steel support with rigid 16 gauge galvanized steel interior panels. Exterior panels have a durable finish coat of outdoor enamel. The top panels are joined with 3/16" diameter rubber tubing in the bottom of each standing seam. Side panels are sealed with polyurethane foam.

● INSULATION

All side panels and top panels are insulated with 1-1/2 inch thick (1-1/2 lb. density-mat faced) fiberglass insulation. In addition the base is insulated with 1 inch thick (6 lb. density) fiberglass insulation and protected by the 16 ga. galvanized drain pan.

● ACCESS PANELS

Equipped with locking type door handles. Heating, blower and filter panels are hinged.

● SERVICE ENCLOSURE (Opt.)

Protects service area from inclement weather during servicing. See bulletin (Page 25) in Accessories section for complete data.

● POWER SAVER LOAD SENSOR CONTROLS (Opt.)

Optional equipment controls fresh air entry and "Free Cooling" with outdoor air. Structures that have high internal gains quite often require cooling at low outdoor air temperatures. Lennox POWER SAVER eliminates the need for mechanical cooling at these temperatures by using the outdoor air for cooling. An enthalpy control, located in the outdoor air stream senses the total heat content (dry bulb and wet bulb temperatures of the outdoor air. This unique control prevents excessive moisture laden outdoor air capable of adding to the cooling load from entering the building and yet permits cool dry outdoor air capable of cooling to enter, thus taking full advantage of free outdoor air cooling. The POWER SAVER equipment may also be specified for manual control. In addition the POWER SAVER dampers are now available factory wired for a fixed minimum position setting. This is a standard option and must be specified when ordering.

● PRESSURE CONVERTER

Mounted to blower discharge snout giving increased performance by converting the kinetic energy of the high velocity blower discharge to static pressure. The converter also gives uniform air distribution.

● EXHAUST DAMPERS

Extruded aluminum dampers ride in nylon bearings.

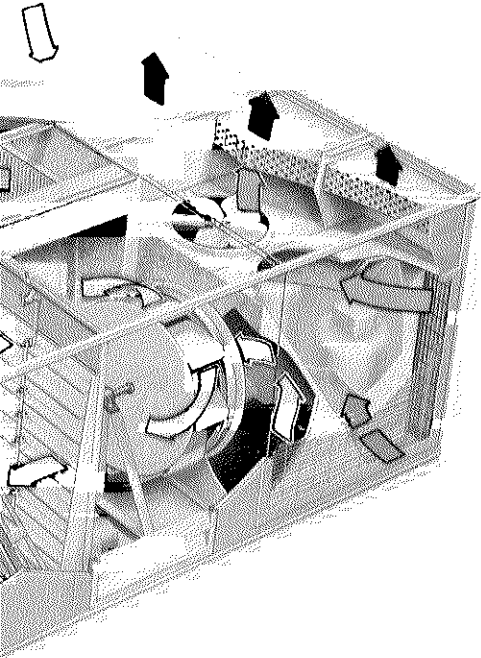

● POWERFUL BLOWERS

Twin 18" x 18" blowers deliver large air volumes with low power consumption. The blower assemblies are mounted to a rugged angle iron frame with the entire blower and frame assembly vibration isolated on coil steel springs. Equipped with permanently lubricated ball bearings. Blower wheels are statically and dynamically balanced. Pivoted motor mounting base permits simple belt tension adjustment or belt changing. A choice of motor hp and drives is available.

● FILTER OPTIONS

Standard Frame Filters—Generous filter area consists of one inch, 20 pores per inch polyurethane media mounted in rugged individual galvanized metal frames. They are easily accessible for servicing. The filter rack is 4" thick which makes room for 3" of additional filtering material — such as activated charcoal.

Bag Filters—Highly efficient bag filters are available in three models; 55%, 85% and 95% efficiency based on National Bureau of Standards dustspot test. Specify efficiency desired when ordering. All three models are equipped with frame prefilters to extend the life of the bag filters.

Automatic Roll Filters—65 ft roll gives an average of 1 year air filtering without servicing. This is based on 72 hours a week unit operation under average dust loading conditions. They are available with an adjustable timed automatic advance or adjustable automatic pressure advance.

● OUTSIDE AIR INTAKE

Outside air (fresh and condenser air) enters through the condensing section. An eliminator section traps rain and keeps it from entering the air handling sections. The trapped moisture drains into the condensing section where it is eliminated through drainage holes.

● RETURN AIR BLOWER (Opt.)

Exhausts are in direct proportion to amount of outside air introduced into system. It can exhaust 80% of total supply air handled and overcomes resistance in return air system. Choice of motor hp and drives available.

● SMOKE DETECTOR CONTROLS (Opt.)

The Photo Cell Smoke Detectors are designed to detect the presence of smoke within the system and to actuate the blower motor controls and other devices to: (1) shut off the entire system or (2) operate only 100% exhaust, venting smoke from the system or (3) operate only 100% outside supply air for evacuation, generating positive pressure preventing smoke from entering an uninvolved area or (4) both 100% outside supply air and exhaust operation for one unit total system applications. Terminals are also available for connection of remote alarm circuits. Actuation occurs when smoke within the unit exceeds a density that is sufficient to obscure light by a factor of 2% to 4% per foot. A key switch is provided for periodic tests. Two detectors are provided, one is located in the return air section and one in the blower section downstream from the air filters. In addition, a remote test/reset control may be provided which acts as a remote test station.

● HOISTING LUGS AND SLING

Four 4 gauge steel lugs with hoisting sling attached are furnished as standard. Installer has only to attach hoisting equipment to sling and place unit in desired location. Each lug will handle a load of 4 G's.

● HEATING OPTIONS

Gas (350,000 to 850,000 Btuh Input)—Single or dual (in series) DURATUBE[®] heat exchangers provide maximum heating efficiency and long service life. Tube and drum construction permit normal heat element expansion and contraction without metal fatigue. A choice of aluminized steel or Lennox DURAGLASS II[®] coated steel heat exchangers is offered. Flame observation port is furnished. True power burner(s) use 100% secondary air. Two stage burner operation is available with natural gas only on 350,000 and 500,000 input models.

Electric (45 to 150 Kw)—Elements are nichrome bare wire exposed directly to the hot deck air stream. Equipped with manual reset backup limits. A choice of heater controls is available: four stage hot deck control or a sequence controller with modulating hot deck control.

Hot Water (200,000 to 1,000,000 Btuh)—Factory installed hot water coil can be with either three-way modulating valve or primary-secondary flow controls. The valve and pump (primary-secondary control) will be factory installed. Coil freezeup protection provided.

Steam Heat (460,000 to 1,110,000 Btuh)—Steam coil is factory installed. Factory installed piping includes a modulating steam valve and float. Coil is pressure leak tested at 450-500 psi. Positive coil freezeup protection is provided.

● CONDENSER SECTION

Three Lennox LANDMARK compressors and their independent refrigerant circuits, condensers and fans give staging control to fit varying cooling load requirements. In addition the No. 1 refrigerant circuit is equipped with capacity reduction. A portion of the compressor discharge gas is by-passed directly into the refrigerant flow and compressor cooling. DMS3-415 model is equipped with three nominal 11 ton single speed compressors. DMS3-600 model is equipped with two new L2 nominal 15 ton single speed and one L6 two speed compressors. These new compressors have the same reliable parts and design as the original L2. In addition the new 15 ton compressors have a sight glass, flanged fitting for the suction line connection and two speed operation (L6 model only) for additional capacity reduction. Two speed control provides maximum efficiency and operation economy during periods of reduced load. See capacity chart. A condenser air discharge grille is available as optional equipment and must be ordered extra.

● EVAPORATOR COIL

Lennox designed and built evaporator has ripple edge aluminum fins machine fitted to seamless copper tubes. The three separate circuits are circuited in row depth. Each circuit has its own independent expansion valve, separate condensing section and complete refrigerant charge.

● INDOOR CONDENSER HEAT (Opt.)

Available as optional equipment. It is activated by the first stage of the heating controller when compressor No. 1 is running. The coil is located in the hot deck and will continue to give approximately 125,000 (DMS3-415) and 155,000 (DMS3-600) Btuh of heat as long as compressor No. 1 is operating and there is a demand for heat. If compressor No. 1 is not operating the entire heating load is handled by the gas, electric, hot water or steam components.

● CHILLED WATER COOLING

Four or six row single circuit coil with factory installed modulating valve. Water line inlet openings are provided in cabinet for ease of entry. Coil is constructed of aluminum fins mechanically bonded to seamless copper tubes. Pressure leak tested at 450 to 500 psi.

● THERMOSTAT FURNISHED

A stainless steel mercury bulb thermostat and mounting plate is furnished for each zone when using the 800 series damper actuator. It mounts to a standard 2 x 3-1/4 electrical box. When the solid state modulating damper actuator is used a compatible room temperature sensing transmitter is furnished. Available with or without exposed set-point and indicating thermometer or with exposed set-point only. Also available with concealed set-point, thermometer and locking screw or with concealed set-point and locking screw only. Specify when ordering. A wall plate adapter (order no. P-8-10531) is required for mounting to a standard electrical box. Adapter must be ordered extra.

● SAFETY CONTROLS

Gas fired models have a pre-purge timer and electronic flame sensor. All models have firestats located in hot deck, cold deck and return air area. Blower switch terminates heat-cool operation in event of abnormal operating conditions. All motors are overload protected. NEC or CEC approved fusing, wiring and disconnect are standard.

MULTIPLE POWER SUPPLY—DMS3-415 & DMS3-600 ELECTRI

Voltage (3ph)	Number of Elements	WITHOUT RETURN AIR BLOWER												5 hp Supply Air Blower Motor									7-1/2 hp Supply Air					
		Supply Air Blower Motor hp												Return Air Blower Motor hp									Return Air Blower					
		5			7-1/2			10			15			1-1/2			3			5			1-1/2			3		
		Minimum Circuit Ampacity			Minimum Circuit Ampacity			Minimum Circuit Ampacity			Minimum Circuit Ampacity			Minimum Circuit Ampacity			Minimum Circuit Ampacity			Minimum Circuit Ampacity			Minimum Circuit Ampacity					
Disc.1 Disc.2 Disc.3			Disc.1 Disc.2 Disc.3			Disc.1 Disc.2 Disc.3			Disc.1 Disc.2 Disc.3			Disc.1 Disc.2 Disc.3			Disc.1 Disc.2 Disc.3			Disc.1 Disc.2 Disc.3			Disc.1 Disc.2 Disc.3			Disc.1 Disc.2 Disc.3				
208	4	30.4	156.5	---	39.8	156.5	---	48.1	156.5	---	67.4	156.5	---	36.1	156.5	---	41.0	156.5	---	47.1	156.5	---	45.5	156.5	---	53.4	156.5	---
	5	30.4	195.6	---	39.8	195.6	---	48.1	195.6	---	67.4	195.6	---	36.1	195.6	---	41.0	195.6	---	47.1	195.6	---	45.5	195.6	---	53.4	195.6	---
	6	30.4	234.8	---	39.8	234.8	---	48.1	234.8	---	67.4	234.8	---	36.1	234.8	---	41.0	234.8	---	47.1	234.8	---	45.5	234.8	---	53.4	234.8	---
	7	72.1	234.8	---	81.5	234.8	---	89.7	234.8	---	108.9	234.8	---	79.2	234.8	---	85.3	234.8	---	92.9	234.8	---	88.6	234.8	---	91.7	234.8	---
	8	111.2	234.8	---	120.6	234.8	---	128.8	234.8	---	148.0	234.8	---	118.3	234.8	---	124.4	234.8	---	132.0	234.8	---	127.7	234.8	---	133.8	234.8	---
	9	150.3	234.8	---	159.7	234.8	---	167.9	234.8	---	187.1	234.8	---	157.4	234.8	---	163.5	234.8	---	171.1	234.8	---	166.8	234.8	---	172.9	234.8	---
230	4	27.7	180.5	---	36.2	180.5	---	43.7	180.5	---	61.2	180.5	---	32.9	180.5	---	37.3	180.5	---	42.9	180.5	---	41.4	180.5	---	45.8	180.5	---
	5	27.7	225.6	---	36.2	225.6	---	43.7	225.6	---	61.2	225.6	---	32.9	225.6	---	37.3	225.6	---	42.9	225.6	---	41.4	225.6	---	45.8	225.6	---
	6	75.1	225.6	---	83.6	225.6	---	91.1	225.6	---	108.5	225.6	---	81.6	225.6	---	87.1	225.6	---	94.1	225.6	---	90.1	225.6	---	95.6	225.6	---
	7	120.2	225.6	---	128.7	225.6	---	136.2	225.6	---	153.6	225.6	---	126.7	225.6	---	132.2	225.6	---	139.2	225.6	---	135.2	225.6	---	140.7	225.6	---
	8	165.3	225.6	---	173.8	225.6	---	181.3	225.6	---	198.7	225.6	---	171.8	225.6	---	177.3	225.6	---	184.3	225.6	---	180.3	225.6	---	185.8	225.6	---
	9	210.4	225.6	---	218.9	225.6	---	226.4	225.6	---	243.8	225.6	---	216.9	225.6	---	222.4	225.6	---	229.4	225.6	---	225.4	225.6	---	230.9	225.6	---
460	4	13.9	90.0	---	18.2	90.0	---	21.9	90.0	---	30.6	90.0	---	16.5	90.0	---	18.7	90.0	---	21.5	90.0	---	20.8	90.0	---	23.0	90.0	---
	5	37.5	67.5	---	41.8	67.5	---	45.5	67.5	---	54.2	67.5	---	40.8	67.5	---	43.5	67.5	---	47.0	67.5	---	45.0	67.5	---	47.8	67.5	---
	6	60.0	90.0	---	64.3	90.0	---	68.0	90.0	---	76.7	90.0	---	63.3	90.0	---	66.0	90.0	---	69.5	90.0	---	67.5	90.0	---	70.3	90.0	---
	7	82.5	90.0	---	86.8	90.0	---	90.5	90.0	---	99.2	90.0	---	85.8	90.0	---	88.5	90.0	---	92.0	90.0	---	90.0	90.0	---	92.8	90.0	---
	8	60.0	67.5	67.5	64.3	67.5	67.5	68.0	67.5	67.5	76.7	67.5	67.5	63.3	67.5	67.5	66.0	67.5	67.5	69.5	67.5	67.5	67.5	67.5	67.5	70.3	67.5	67.5
	9	60.0	67.5	90.0	64.3	67.5	90.0	68.0	67.5	90.0	76.7	67.5	90.0	63.3	67.5	90.0	66.0	67.5	90.0	69.5	67.5	90.0	67.5	67.5	90.0	70.3	67.5	90.0
575	4	11.1	72.0	---	14.7	72.0	---	17.3	72.0	---	24.7	72.0	---	13.2	72.0	---	15.0	72.0	---	17.2	72.0	---	16.8	72.0	---	18.6	72.0	---
	5	11.1	90.0	---	14.7	90.0	---	17.3	90.0	---	24.7	90.0	---	13.2	90.0	---	15.0	90.0	---	17.2	90.0	---	16.8	90.0	---	18.6	90.0	---
	6	11.1	108.0	---	14.7	108.0	---	17.3	108.0	---	24.7	108.0	---	13.2	108.0	---	15.0	108.0	---	17.2	108.0	---	16.8	108.0	---	18.6	108.0	---
	7	30.0	108.0	---	33.6	108.0	---	36.1	108.0	---	43.6	108.0	---	32.6	108.0	---	34.9	108.0	---	37.6	108.0	---	36.2	108.0	---	38.5	108.0	---
	8	48.0	108.0	---	51.6	108.0	---	54.1	108.0	---	61.6	108.0	---	50.6	108.0	---	52.9	108.0	---	55.6	108.0	---	54.2	108.0	---	56.5	108.0	---
	9	66.0	108.0	---	69.6	108.0	---	72.1	108.0	---	79.6	108.0	---	68.6	108.0	---	70.9	108.0	---	73.6	108.0	---	72.2	108.0	---	74.5	108.0	---

NOTE—Refer to National Electrical Code manual to determine wire, fuse and disconnect size requirements. Use wires suitable for at least 75C (16

1DMS3-415
++DMS3-600

MULTIPLE POWER SUPPLY—DMS3-415 D)

Voltage (3ph)	Number of Elements	WITHOUT RETURN AIR BLOWER												5hp Supply Air Blower Motor									WITH RETURN AIR					
		Supply Air Blower Motor hp												Return Air Blower Motor hp									7-1/2 hp Supply Air					
		5			7-1/2			10			15			1-1/2			3			5			1-1/2			3		
		Minimum Circuit Ampacity			Minimum Circuit Ampacity			Minimum Circuit Ampacity			Minimum Circuit Ampacity			Minimum Circuit Ampacity			Minimum Circuit Ampacity			Minimum Circuit Ampacity			Minimum Circuit Ampacity					
Disc.1 Disc.2 Disc.3			Disc.1 Disc.2 Disc.3			Disc.1 Disc.2 Disc.3			Disc.1 Disc.2 Disc.3			Disc.1 Disc.2 Disc.3			Disc.1 Disc.2 Disc.3			Disc.1 Disc.2 Disc.3			Disc.1 Disc.2 Disc.3			Disc.1 Disc.2 Disc.3				
208	4	140.8	156.5	---	148.3	156.5	---	154.9	156.5	---	170.3	156.5	---	146.5	156.5	---	151.4	156.5	---	157.5	156.5	---	154.0	156.5	---	159.9	156.5	---
	5	140.8	195.6	---	148.3	195.6	---	154.9	195.6	---	170.3	195.6	---	146.5	195.6	---	151.4	195.6	---	157.5	195.6	---	154.0	195.6	---	159.9	195.6	---
	6	140.8	234.8	---	148.3	234.8	---	154.9	234.8	---	170.3	234.8	---	146.5	234.8	---	151.4	234.8	---	157.5	234.8	---	154.0	234.8	---	159.9	234.8	---
	7	140.8	234.8	---	148.3	234.8	---	154.9	234.8	---	170.3	234.8	---	146.5	234.8	---	151.4	234.8	---	157.5	234.8	---	154.0	234.8	---	159.9	234.8	---
	8	140.8	234.8	---	148.3	234.8	---	154.9	234.8	---	170.3	234.8	---	146.5	234.8	---	151.4	234.8	---	157.5	234.8	---	154.0	234.8	---	159.9	234.8	---
	9	150.3	234.8	---	159.7	234.8	---	167.9	234.8	---	187.1	234.8	---	157.4	234.8	---	163.5	234.8	---	171.1	234.8	---	166.8	234.8	---	172.9	234.8	---
230	4	137.6	180.5	---	144.4	180.5	---	150.4	180.5	---	164.4	180.5	---	142.8	180.5	---	147.2	180.5	---	152.8	180.5	---	149.6	180.5	---	154.6	180.5	---
	5	137.6	225.6	---	144.4	225.6	---	150.4	225.6	---	164.4	225.6	---	142.8	225.6	---	147.2	225.6	---	152.8	225.6	---	149.6	225.6	---	154.6	225.6	---
	6	137.6	225.6	---	144.4	225.6	---	150.4	225.6	---	164.4	225.6	---	142.8	225.6	---	147.2	225.6	---	152.8	225.6	---	149.6	225.6	---	154.6	225.6	---
	7	137.6	225.6	---	144.4	225.6	---	150.4	225.6	---	164.4	225.6	---	142.8	225.6	---	147.2	225.6	---	152.8	225.6	---	149.6	225.6	---	154.6	225.6	---
	8	165.3	225.6	---	173.8	225.6	---	181.3	225.6	---	198.7	225.6	---	171.8	225.6	---	177.3	225.6	---	184.3	225.6	---	180.3	225.6	---	185.8	225.6	---
	9	210.4	225.6	---	218.9	225.6	---	226.4	225.6	---	243.8	225.6	---	216.9	225.6	---	222.4	225.6	---	229.4	225.6	---	225.4	225.6	---	230.9	225.6	---
460	4	67.7	90.0	---	71.1	90.0	---	74.1	90.0	---	81.0	90.0	---	70.3	90.0	---	72.5	90.0	---	75.3	90.0	---	73.7	90.0	---	76.9	90.0	---
	5	67.7	90.0	---	71.1	90.0	---	74.1	90.0	---	81.0	90.0	---	70.3	90.0	---	72.5	90.0	---	75.3	90.0	---	73.7	90.0	---	76.9	90.0	---
	6	67.7	90.0	---	71.1	90.0	---	74.1	90.0	---	81.0	90.0	---	70.3	90.0	---	72.5	90.0	---	75.3	90.0	---	73.7	90.0	---	76.9	90.0	---
	7	82.5	90.0	---	86.8	90.0	---	90.5	90.0	---	99.2	90.0	---	85.8	90.0	---	88.5	90.0	---	92.0	90.0	---	90.0	90.0	---	92.8	90.0	---
	8	67.7	67.5	67.5	71.1	67.5	67.5	74.1	67.5	67.5	81.0	67.5	67.5	70.3	67.5	67.5	72.5	67.5	67.5	75.3	67.5	67.5	73.7	67.5	67.5	76.9	67.5	67.5
	9	67.7	67.5	90.0	71.1	67.5	90.0	74.1	67.5	90.0	81.0	67.5	90.0	70.3	67.5	90.0	72.5	67.5	90.0	75.3	67.5	90.0	73.7	67.5	90.0	76.9	67.5	90.0
575	4	68.3	72.0	---	71.2	72.0	---	73.2	72.0	---	79.2	72.0	---	70.4	72.0	---	72.2	72.0	---	74.4	72.0	---	73.3	72.0	---	76.1	72.0	---
	5	68.3	90.0	---	71.2	90.0	---	73.2	90.0	---	79.2	90.0	---	70.4	90.0	---	72.2	90.0	---	74.4	90.0	---	73.3	90.0	---	76.1	90.0	---
	6	68.3	108.0	---	71.2	108.0	---	73.2	108.0	---	79.2	108.0	---	70.4	108.0	---	72.2	108.0	---	74.4	108.0	---	73.3	108.0	---	76.1	108.0	---

ELECTRIC HEAT ONLY (With or Without CHILLED WATER)

WITH RETURN AIR BLOWER

Supply Air Blower Motor		10 hp Supply Air Blower Motor												15 hp Supply Air Blower Motor												
Return Air Blower Motor hp		Return Air Blower Motor hp												Return Air Blower Motor hp												
3		1-1/2				3				5				1-1/2			3			5			7-1/2			
Minimum Circuit Ampacity	Minimum Circuit Ampacity	Minimum Circuit Ampacity		Minimum Circuit Ampacity		Minimum Circuit Ampacity		Minimum Circuit Ampacity		Minimum Circuit Ampacity		Minimum Circuit Ampacity		Minimum Circuit Ampacity		Minimum Circuit Ampacity		Minimum Circuit Ampacity		Minimum Circuit Ampacity		Minimum Circuit Ampacity				
Disc.1	Disc.2	Disc.3	Disc.1	Disc.2	Disc.3	Disc.1	Disc.2	Disc.3	Disc.1	Disc.2	Disc.3	Disc.1	Disc.2	Disc.3	Disc.1	Disc.2	Disc.3	Disc.1	Disc.2	Disc.3	Disc.1	Disc.2	Disc.3			
3.4	156.5	---	50.5	156.5	---	53.8	156.5	---	58.7	156.5	---	64.8	156.5	---	73.1	156.5	---	78.0	156.5	---	84.1	156.5	---	91.6	156.5	---
3.4	195.6	---	56.5	195.6	---	53.8	195.6	---	58.7	195.6	---	64.8	195.6	---	73.1	195.6	---	78.0	195.6	---	84.1	195.6	---	91.6	195.6	---
3.4	234.8	---	56.5	234.8	---	53.8	234.8	---	58.7	234.8	---	64.8	234.8	---	73.1	234.8	---	78.0	234.8	---	84.1	234.8	---	91.6	234.8	---
4.7	234.8	---	102.3	234.8	---	96.8	234.8	---	102.9	234.8	---	110.6	234.8	---	116.0	234.8	---	122.2	234.8	---	129.8	234.8	---	139.2	234.8	---
3.8	234.8	---	141.4	234.8	---	135.9	234.8	---	142.0	234.8	---	149.7	234.8	---	155.1	234.8	---	161.3	234.8	---	168.9	234.8	---	178.3	234.8	---
2.9	234.8	---	180.5	234.8	---	175.0	234.8	---	181.1	234.8	---	188.8	234.8	---	194.2	234.8	---	200.4	234.8	---	208.0	234.8	---	217.4	234.8	---
2.0	234.8	---	219.6	234.8	---	214.1	234.8	---	220.2	234.8	---	227.9	234.8	---	233.4	234.8	---	239.5	234.8	---	242.8	234.8	---	---	---	---
5.8	180.5	---	51.4	180.5	---	48.9	180.5	---	53.3	180.5	---	58.9	180.5	---	66.4	180.5	---	70.8	180.5	---	76.4	180.5	---	83.2	180.5	---
5.8	225.6	---	51.4	225.6	---	48.9	225.6	---	53.3	225.6	---	58.9	225.6	---	66.4	225.6	---	70.8	225.6	---	76.4	225.6	---	83.2	225.6	---
5.6	225.6	---	102.6	225.6	---	97.5	225.6	---	103.0	225.6	---	110.0	225.6	---	115.0	225.6	---	120.5	225.6	---	127.5	225.6	---	136.0	225.6	---
0.7	225.6	---	147.7	225.6	---	142.6	225.6	---	148.1	225.6	---	155.1	225.6	---	160.1	225.6	---	162.5	225.6	---	172.6	225.6	---	181.1	225.6	---
5.8	225.6	---	192.8	225.6	---	187.8	225.6	---	193.2	225.6	---	200.2	225.6	---	205.2	225.6	---	210.8	225.6	---	217.8	225.6	---	226.2	225.6	---
0.9	225.6	---	237.9	225.6	---	232.9	225.6	---	238.4	225.6	---	243.9	225.6	---	243.9	225.6	---	243.9	225.6	---	243.9	225.6	---	---	---	---
3.0	90.0	---	25.8	90.0	---	24.5	90.0	---	26.7	90.0	---	29.5	90.0	---	33.2	90.0	---	35.4	90.0	---	38.2	90.0	---	41.6	90.0	---
7.8	67.5	---	51.2	67.5	---	48.8	67.5	---	51.5	67.5	---	55.0	67.5	---	57.5	67.5	---	60.2	67.5	---	63.8	67.5	---	68.0	67.5	---
7.8	90.0	---	51.2	90.0	---	48.8	90.0	---	51.5	90.0	---	55.0	90.0	---	57.5	90.0	---	60.2	90.0	---	63.8	90.0	---	68.0	90.0	---
1.3	90.0	---	73.7	90.0	---	71.3	90.0	---	74.0	90.0	---	77.5	90.0	---	80.9	90.0	---	82.7	90.0	---	86.3	90.0	---	90.5	90.0	---
3.8	90.0	---	96.2	90.0	---	93.8	90.0	---	96.5	90.0	---	100.0	90.0	---	102.5	90.0	---	106.2	90.0	---	108.8	90.0	---	99.2	103.7	---
1.3	67.5	67.5	73.7	67.5	67.5	71.3	67.5	67.5	74.0	67.5	67.5	77.5	67.5	67.5	80.0	67.5	67.5	82.7	67.5	67.5	86.3	67.5	67.5	76.7	81.2	67.5
1.3	67.5	90.0	73.7	67.5	90.0	71.3	67.5	90.0	74.0	67.5	90.0	77.5	67.5	90.0	80.0	67.5	90.0	82.7	67.5	90.0	86.3	67.5	90.0	76.7	81.2	90.0
1.3	90.0	90.0	73.7	90.0	90.0	71.3	90.0	90.0	74.0	90.0	90.0	77.5	90.0	90.0	80.0	90.0	90.0	82.7	90.0	90.0	86.3	90.0	90.0	76.7	103.7	90.0
3.6	72.0	---	20.8	72.0	---	19.4	72.0	---	21.2	72.0	---	23.4	72.0	---	26.8	72.0	---	28.6	72.0	---	30.8	72.0	---	33.7	72.0	---
3.6	90.0	---	20.8	90.0	---	19.4	90.0	---	21.2	90.0	---	23.4	90.0	---	26.8	90.0	---	28.6	90.0	---	30.8	90.0	---	33.7	90.0	---
3.6	108.0	---	20.8	108.0	---	19.4	108.0	---	21.2	108.0	---	23.4	108.0	---	26.8	108.0	---	28.6	108.0	---	30.8	108.0	---	33.7	108.0	---
3.5	108.0	---	41.2	108.0	---	38.8	108.0	---	41.0	108.0	---	43.8	108.0	---	46.2	108.0	---	48.5	108.0	---	51.2	108.0	---	54.7	108.0	---
3.5	108.0	---	59.2	108.0	---	56.8	108.0	---	59.0	108.0	---	61.8	108.0	---	64.2	108.0	---	66.5	108.0	---	69.2	108.0	---	72.7	108.0	---
3.5	108.0	---	77.2	108.0	---	74.8	108.0	---	77.0	108.0	---	79.8	108.0	---	82.2	108.0	---	84.5	108.0	---	87.2	108.0	---	90.7	108.0	---
3.5	108.0	---	95.2	108.0	---	92.8	108.0	---	95.0	108.0	---	97.8	108.0	---	100.2	108.0	---	102.5	108.0	---	105.2	108.0	---	108.7	108.0	---

75C (167F).

415 DX COOLING AND ELECTRIC HEAT

Supply Air Blower Motor		10 hp Supply Air Blower Motor												15 hp Supply Air Blower Motor												
Return Air Blower Motor hp		Return Air Blower Motor hp												Return Air Blower Motor hp												
3		1-1/2				3				5				1-1/2			3			5			7-1/2			
Minimum Circuit Ampacity	Minimum Circuit Ampacity	Minimum Circuit Ampacity		Minimum Circuit Ampacity		Minimum Circuit Ampacity		Minimum Circuit Ampacity		Minimum Circuit Ampacity		Minimum Circuit Ampacity		Minimum Circuit Ampacity		Minimum Circuit Ampacity		Minimum Circuit Ampacity		Minimum Circuit Ampacity		Minimum Circuit Ampacity				
Disc.1	Disc.2	Disc.3	Disc.1	Disc.2	Disc.3	Disc.1	Disc.2	Disc.3	Disc.1	Disc.2	Disc.3	Disc.1	Disc.2	Disc.3	Disc.1	Disc.2	Disc.3	Disc.1	Disc.2	Disc.3	Disc.1	Disc.2	Disc.3			
3.9	156.5	---	165.0	156.5	---	158.8	156.5	---	165.5	157.5	---	171.6	156.5	---	176.0	156.5	---	180.9	156.5	---	187.0	156.5	---	194.5	156.5	---
3.9	195.6	---	165.0	195.6	---	158.8	195.6	---	165.5	195.6	---	171.6	195.6	---	176.0	195.6	---	180.9	195.6	---	187.0	195.6	---	194.5	195.6	---
3.9	234.8	---	165.0	234.8	---	158.8	234.8	---	165.5	234.8	---	171.6	234.8	---	176.0	234.8	---	180.9	234.8	---	187.0	234.8	---	194.5	234.8	---
3.9	234.8	---	165.0	234.8	---	158.8	234.8	---	165.5	234.8	---	171.6	234.8	---	176.0	234.8	---	180.9	234.8	---	187.0	234.8	---	194.5	234.8	---
3.9	234.8	---	165.0	234.8	---	158.8	234.8	---	165.5	234.8	---	171.6	234.8	---	176.0	234.8	---	180.9	234.8	---	187.0	234.8	---	194.5	234.8	---
2.0	234.8	---	219.6	234.8	---	214.1	234.8	---	220.2	234.8	---	227.9	234.8	---	233.4	234.8	---	239.5	234.8	---	242.8	234.8	---	---	---	---
4.6	180.5	---	159.6	180.5	---	155.6	180.5	---	160.0	180.5	---	165.6	180.5	---	169.6	180.5	---	174.0	180.5	---	179.8	180.5	---	186.4	180.5	---
4.6	225.6	---	159.6	225.6	---	155.6	225.6	---	160.0	225.6	---	165.6	225.6	---	169.6	225.6	---	174.0	225.6	---	179.8	225.6	---	186.4	225.6	---
1.6	225.6	---	159.6	225.6	---	155.6	225.6	---	160.0	225.6	---	165.6	225.6	---	169.6	225.6	---	174.0	225.6	---	179.8	225.6	---	186.4	225.6	---
1.6	225.6	---	159.6	225.6	---	155.6	225.6	---	160.0	225.6	---	165.6	225.6	---	169.6	225.6	---	174.0	225.6	---	179.8	225.6	---	186.4	225.6	---
3.8	225.6	---	192.8	225.6	---	187.8	225.6	---	193.2	225.6	---	200.2	225.6	---	205.2	225.6	---	210.8	225.6	---	217.8	225.6	---	226.2	225.6	---
1.9	225.6	---	237.9	225.6	---	232.9	225.6	---	238.4	225.6	---	243.9	225.6	---	243.9	225.6	---	243.9	225.6	---	243.9	225.6	---	---	---	---
9	90.0	---	78.7	90.0	---	76.7	90.0	---	78.9	90.0	---	81.7	90.0	---	83.7	90.0	---	85.9	90.0	---	88.7	90.0	---	92.1	90.0	---
9	90.0	---	78.7	90.0	---	76.7	90.0	---	78.9	90.0	---	81.7	90.0	---	83.7	90.0	---	85.9	90.0	---	88.7	90.0	---	92.1	90.0	---
9	90.0	---	78.7	90.0	---	76.7	90.0	---	78.9	90.0	---	81.7	90.0	---	83.7	90.0	---	85.9	90.0	---	88.7	90.0	---	92.1	90.0	---
8	90.0	---	96.2	90.0	---	93.8	90.0	---	96.5	90.0	---	100.0	90.0	---	102.5	90.0	---	106.2	90.0	---	108.8	90.0	---	99.2	103.7	---
9	67.5	67.5	78.7	67.5	67.5	76.7	67.5	67.5	78.9	67.5	67.5	81.7	67.5	67.5	83.7	67.5	67.5	85.9	67.5	67.5	88.7	67.5	67.5	92.1	81.2	67.5
9	67.5	90.0	78.7	67.5	90.0	76.7	67.5	90.0	78.9	67.5	90.0	81.7	67.5	90.0	83.7	67.5	90.0	85.9	67.5	90.0	88.7	67.5	90.0	92.1	81.2	90.0
9	90.0	90.0	78.7	90.0	90.0	76.7	90.0	90.0	78.9	90.0	90.0	81.7	90.0	90.0	83.7	90.0	90.0	85.9	90.0	90.0	88.7	90.0	90.0	92.1	103.7	90.0
1	72.0	---	77.3	72.0	---	75.3	72.0	---	77.1	72.0	---	79.3	72.0	---	81.3	72.0	---	83.1	72.0	---	85.3	72.0	---	88.2	72.0	---
1	90.0	---	77.3	90.0	---	75.3	90.0	---	77.1	90.0	---	79.3	90.0	---	81.3	90.0	---	83.1	90.							

SINGLE POWER SUPPLY –DMS3-415 & DMS3-600 ELECTRIC HEAT ONLY (With or Without CHILLED WATER)

Voltage (3 ph)	Number of Elements	WITHOUT RETURN AIR BLOWER				WITH RETURN AIR BLOWER												
		Supply Air Blower Motor hp				5 hp Supply Air Blower Motor			7-1/2 hp Supply Air Blower Motor			10 hp Supply Air Blower Motor			15 hp Supply Air Blower Motor			
		5	7-1/2	10	15	Return Air Blower Motor hp			Return Air Blower Motor hp			Return Air Blower Motor hp			Return Air Blower Motor hp			
Minimum Circuit Ampacity	Minimum Circuit Ampacity	Minimum Circuit Ampacity	Minimum Circuit Ampacity	1-1/2	3	5	1-1/2	3	5	1-1/2	3	5	1-1/2	3	5	7-1/2		
208	4	186.9	196.3	204.6	223.9	192.6	197.5	203.6	202.0	206.9	213.0	210.3	215.2	221.3	229.6	234.5	240.6	248.1
	5	226.0	235.4	243.7	263.0	231.7	236.6	242.7	241.1	246.0	252.1	249.4	254.3	260.4	268.7	273.6	279.7	287.2
	6	265.2	274.6	282.9	302.2	270.9	275.8	281.9	280.3	285.2	291.3	288.6	293.5	299.6	307.9	312.8	318.9	326.4
	7	306.9	316.3	324.5	343.7	314.0	320.1	327.7	323.4	329.5	335.1	331.6	337.7	345.4	350.8	357.0	364.6	374.0
	8	346.0	355.4	363.6	382.8	353.1	359.2	366.8	362.5	368.6	376.2	370.7	376.8	384.5	389.9	396.1	403.7	413.1
	9	385.1	394.5	402.7	421.9	392.2	398.3	405.9	401.6	407.7	415.3	409.8	415.9	423.6	429.0	435.2	442.8	452.2
	10	424.2	433.6	441.8	461.0	431.3	437.4	445.0	440.7	446.8	454.4	448.9	455.0	462.4	467.8	474.3	477.6	---
	4	208.2	216.7	224.2	241.7	213.4	217.8	223.4	221.4	226.3	231.9	229.4	233.8	239.4	246.9	251.3	256.9	263.7
	5	253.3	261.8	269.3	286.8	258.5	262.9	268.5	267.0	271.4	277.0	274.5	278.9	284.5	292.0	296.4	302.0	308.8
	6	300.7	309.2	316.7	334.1	307.2	312.7	319.7	315.7	321.2	328.2	323.1	328.6	335.6	340.6	346.1	353.1	361.6
7	345.8	354.3	361.8	379.2	352.3	357.8	364.8	360.8	366.3	373.3	368.2	373.7	380.7	385.7	391.2	398.2	406.7	
8	390.9	399.4	406.9	424.4	397.4	402.9	409.9	405.9	411.4	418.4	413.4	418.8	425.8	430.8	436.4	443.4	451.8	
9	436.0	444.5	452.0	469.5	442.5	448.0	455.0	451.0	456.5	463.5	458.5	464.0	471.0	476.0	481.5	487.8	---	
230	4	105.0	109.3	113.0	121.7	108.3	111.0	114.5	112.5	115.3	118.7	116.3	119.0	122.5	125.0	127.7	131.3	135.5
	5	127.5	131.8	135.5	144.2	130.8	133.5	137.0	135.0	137.8	141.2	138.8	141.5	145.0	147.5	150.2	153.8	158.0
	6	150.0	154.3	158.0	166.7	153.3	156.0	159.5	157.0	160.3	163.7	161.3	164.0	167.5	170.0	172.7	176.3	180.5
	7	172.5	176.8	180.5	189.2	175.8	178.0	182.0	180.0	182.8	186.2	183.8	186.5	190.0	192.5	195.2	198.8	202.9
	8	195.0	199.3	203.0	211.7	198.3	201.0	204.5	202.5	205.3	208.7	206.3	209.0	212.5	215.0	217.7	221.3	225.4
	9	217.5	221.8	225.5	234.2	220.8	223.5	227.0	225.0	227.8	231.2	228.8	231.5	235.0	237.5	240.2	243.8	247.9
	10	240.0	244.3	248.0	256.7	243.3	246.0	249.5	247.5	250.3	253.7	251.3	254.0	257.5	260.0	262.7	266.3	270.4
	4	83.1	86.7	89.4	96.7	85.2	87.0	89.2	88.8	90.6	92.8	91.4	93.2	95.4	98.8	100.6	102.8	105.7
	5	101.1	104.7	107.3	114.7	103.2	105.0	107.2	106.8	108.6	110.8	109.4	111.2	113.4	116.8	118.6	120.8	123.7
	6	119.1	122.7	125.3	132.7	121.2	123.0	125.2	124.8	126.6	128.8	127.4	129.2	131.4	134.8	136.6	138.8	141.7
7	138.0	141.6	144.1	151.6	140.6	142.9	145.6	144.2	146.5	149.2	146.8	149.0	151.8	154.2	156.5	159.2	162.7	
8	156.0	159.6	162.1	169.6	158.6	160.9	163.6	162.2	164.5	167.2	164.8	167.0	169.8	172.2	174.5	177.2	180.7	
9	174.0	177.6	180.1	187.6	176.6	178.9	181.6	180.2	182.5	185.2	182.8	185.0	187.8	190.2	192.5	195.2	198.7	
10	192.0	195.6	198.0	205.6	194.6	196.9	199.6	198.2	200.5	203.2	200.8	203.0	205.8	208.2	210.5	213.2	216.7	

NOTE Refer to National Electrical Code manual to determine wire, fuse and disconnect size requirements. Use wires suitable for at least 75C (167F).

SINGLE POWER SUPPLY –DMS3-415 DX COOLING AND ELECTRIC HEAT

Voltage (3 ph)	Number of Elements	WITHOUT RETURN AIR BLOWER				WITH RETURN AIR BLOWER												
		Supply Air Blower Motor hp				5 hp Supply Air Blower Motor			7-1/2 hp Supply Air Blower Motor			10 hp Supply Air Blower Motor			15 hp Supply Air Blower Motor			
		5	7-1/2	10	15	Return Air Blower Motor hp			Return Air Blower Motor hp			Return Air Blower Motor hp			Return Air Blower Motor hp			
Minimum Circuit Ampacity	Minimum Circuit Ampacity	Minimum Circuit Ampacity	Minimum Circuit Ampacity	1-1/2	3	5	1-1/2	3	5	1-1/2	3	5	1-1/2	3	5	7-1/2		
208	4	231.3	238.8	245.4	260.8	237.0	241.9	248.0	244.5	249.0	255.5	251.1	256.0	262.1	266.5	271.4	276.5	285.0
	5	231.3	238.8	245.4	260.8	237.0	241.9	248.0	244.5	249.0	255.5	251.1	256.0	262.1	266.5	271.4	276.5	285.0
	6	265.2	274.6	282.9	302.2	270.9	275.8	281.9	280.3	285.2	291.3	288.6	293.5	299.6	307.9	312.8	318.9	326.4
	7	306.9	316.3	324.5	343.7	314.0	320.1	327.7	323.4	329.5	335.1	331.6	337.7	345.4	350.8	357.0	364.6	374.0
	8	346.0	355.4	363.6	382.8	353.1	359.2	366.8	362.5	368.6	376.2	370.7	376.8	384.5	389.9	396.1	403.7	413.1
	9	385.1	394.5	402.7	421.9	392.2	398.3	405.9	401.6	407.7	415.3	409.8	415.9	423.6	429.0	435.2	442.8	452.2
	10	424.2	433.6	441.8	461.0	431.3	437.4	445.0	440.7	446.8	454.4	448.9	455.0	462.4	467.8	474.3	477.6	---
	4	233.7	240.5	246.5	260.5	238.9	243.3	248.9	245.7	250.1	255.7	251.7	256.1	261.7	265.7	270.1	275.7	282.5
	5	253.3	261.8	269.3	286.8	258.5	262.9	268.5	267.0	271.4	277.0	274.5	278.9	284.5	292.0	296.4	302.0	308.8
	6	300.7	309.2	316.7	334.1	307.2	312.7	319.7	315.7	321.2	328.2	323.1	328.6	335.6	340.6	346.1	353.1	361.6
7	345.8	354.3	361.8	379.2	352.3	357.8	364.8	360.8	366.3	373.3	368.2	373.7	380.7	385.7	391.2	398.2	406.7	
8	390.9	399.4	406.9	424.4	397.4	402.9	409.9	405.9	411.4	418.4	413.4	418.8	425.8	430.8	436.4	443.4	451.8	
9	436.0	444.5	452.0	469.5	442.5	448.0	455.0	451.0	456.5	463.5	458.5	464.0	471.0	476.0	481.5	487.8	---	
230	4	115.2	118.6	121.6	128.6	117.8	120.0	122.8	121.2	123.4	126.5	124.2	126.4	129.2	131.2	133.4	136.2	139.6
	5	127.5	131.8	135.5	144.2	130.8	133.5	137.0	135.0	137.8	141.2	138.8	141.5	145.0	147.5	150.2	153.8	158.0
	6	150.0	154.3	158.0	166.7	153.3	156.0	159.5	157.0	160.3	163.7	161.3	164.0	167.5	170.0	172.7	176.3	180.5
	7	172.5	176.8	180.5	189.2	175.8	178.0	182.0	180.0	182.8	186.2	183.8	186.5	190.0	192.5	195.2	198.8	202.9
	8	195.0	199.3	203.0	211.7	198.3	201.0	204.5	202.5	205.3	208.7	206.3	209.0	212.5	215.0	217.7	221.3	225.4
	9	217.5	221.8	225.5	234.2	220.8	223.5	227.0	225.0	227.8	231.2	228.8	231.5	235.0	237.5	240.2	243.8	247.9
	10	240.0	244.3	248.0	256.7	243.3	246.0	249.5	247.5	250.3	253.7	251.3	254.0	257.5	260.0	262.7	266.3	270.4
	4	86.3	89.2	91.2	97.2	88.4	90.2	92.4	91.3	93.1	95.3	93.3	95.1	97.3	99.3	101.1	103.3	106.2
	5	101.1	104.7	107.3	114.7	103.2	105.0	107.2	106.8	108.6	110.8	109.4	111.2	113.4	116.8	118.6	120.8	123.7
	6	119.1	122.7	125.3	132.7	121.2	123.0	125.2	124.8	126.6	128.8	127.4	129.2	131.4	134.8	136.6	138.8	141.7
7	138.0	141.6	144.1	151.6	140.6	142.9	145.6	144.2	146.5	149.2	146.8	149.0	151.8	154.2	156.5	159.2	162.7	
8	156.0	159.6	162.1	169.6	158.6	160.9	163.6	162.2	164.5	167.2	164.8	167.0	169.8	172.2	174.5	177.2	180.7	
9	174.0	177.6	180.1	187.6	176.6	178.9	181.6	180.2	182.5	185.2	182.8	185.0	187.8	190.2	192.5	195.2	198.7	
10	192.0	195.6	198.0	205.6	194.6	196.9	199.6	198.2	200.5	203.2	200.8	203.0	205.8	208.2	210.5	213.2	216.7	

NOTE—Refer to National Electrical Code manual to determine wire, fuse and disconnect size requirements. Use wires suitable for at least 75C (167F).

SINGLE POWER SUPPLY –DMS3-600 DX COOLING AND ELECTRIC HEAT

Voltage (3 ph)	Number of Elements	WITHOUT RETURN AIR BLOWER				WITH RETURN AIR BLOWER												
		Supply Air Blower Motor hp				5 hp Supply Air Blower Motor			7-1/2 hp Supply Air Blower Motor			10 hp Supply Air Blower Motor			15 hp Supply Air Blower Motor			
		5	7-1/2	10	15	Return Air Blower Motor hp												

FIELD WIRING

NOTE—Correct size unit disconnect is furnished and factory installed.

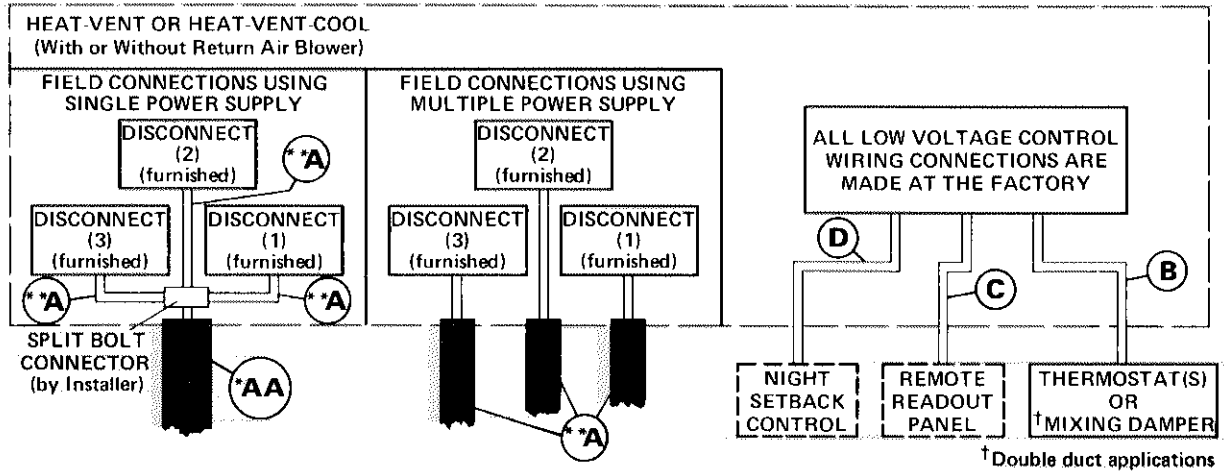

*Refer to Single Power Supply Electrical Data table for sizing values.

**Refer to Multiple Power Supply Electrical Data table for sizing values.

AA—3 wire power (For 208, 230, 460 and 575 volt models.)

A—6 wire power (For 208, 230, 460 and 575 volt models.)

—9 wire power (For 460 volt models—8 or more elements.)

B—2 wire low voltage (From terminal strip to each load sensor thermostat.)

—4 wire low voltage (When double duct mixing boxes with load sensor are used.)

—4 wire low voltage (From terminal strip to each electronic load analyzer

room temperature sensing transmitter [Thermostat].)

—3 wire low voltage (1 signal wire to each Transmitter [Thermostat]. 2 power supply wires, 24 VDC.)
(When double duct mixing boxes with electronic load analyzer are used.)

C—9 wire low voltage (From terminal strip to optional remote readout control panel.)

D—2 wire low voltage (From terminal strip to night setback or system switch.)

NOTE—Unit is equipped with 100% branch fusing.

ELECTRICAL DATA

ELECTRIC HEAT RATINGS

Elements	Volts Input	208V	220/240V	440/480V	550/600V
4	Kw Input	45.0	50.5/60.0	50.5/60.0	50.5/60.0
	Btuh Output	153,500	169,800/204,600	169,800/204,600	169,800/204,600
5	Kw Input	56.3	63.0/75.0	63.0/75.0	63.0/75.0
	Btuh Output	191,800	212,300/255,800	212,300/255,800	212,300/255,800
6	Kw Input	67.5	75.6/90.0	75.6/90.0	75.6/90.0
	Btuh Output	230,200	254,700/306,900	254,700/306,900	254,700/306,900
7	Kw Input	78.8	88.4/105.0	88.4/105.0	88.4/105.0
	Btuh Output	268,500	297,200/358,000	297,200/358,000	297,200/358,000
8	Kw Input	90.0	101.0/120.0	101.0/120.0	101.0/120.0
	Btuh Output	306,900	339,600/409,200	339,600/409,200	339,600/409,200
9	Kw Input	101.3	113.6/135.0	113.6/135.0	113.6/135.0
	Btuh Output	345,300	382,100/460,400	382,100/460,400	382,100/460,400
10	Kw Input	112.5	----	126.1/150.0	126.1/150.0
	Btuh Output	383,600	----	424,500/511,500	424,500/511,500

DMS3-415 DX COOLING AND ELECTRIC HEAT ELECTRICAL DATA

Voltage (three phase)		208V	230V	460V	575V	
Compressors	Full Load Amps (each)	46.7	46.7	22.8	16.5	
	Power Factor	.85	.85	.85	.85	
	Locked Rotor Amps (each)	240.0	240.0	128.0	92.0	
Condenser Fan Motors	Full Load Amps (each)	4.7	4.3	2.2	1.7	
	Horsepower	(3)-1	(3)-1	(3)-1	(3)-1	
Supply Air Blower Motor	5 hp	Full Load Amps	16.7	15.2	7.6	6.1
		Locked Rotor Amps	101.0	92.0	46.0	37.0
	7-1/2 hp	Full Load Amps	24.2	22.0	11.0	9.0
		Locked Rotor Amps	155.0	150.0	75.0	56.0
	10 hp	Full Load Amps	30.8	28.0	14.0	11.0
		Locked Rotor Amps	194.0	175.0	88.0	70.0
	15 hp	Full Load Amps	46.2	42.0	21.0	17.0
		Locked Rotor Amps	264.0	240.0	120.0	96.0
Return Air Blower Motor	1-1/2 hp	Full Load Amps	5.7	5.2	2.6	2.1
		Locked Rotor Amps	44.0	31.6	15.8	12.8
	3 hp	Full Load Amps	10.6	9.6	4.8	3.9
		Locked Rotor Amps	70.0	64.0	32.0	26.0
	5 hp	Full Load Amps	16.7	15.2	7.6	6.1
		Locked Rotor Amps	101.0	92.0	46.0	37.0
	7-1/2 hp	Full Load Amps	24.2	22.0	11.0	9.0
		Locked Rotor Amps	155.0	150.0	75.0	56.0
2 KVA transformer full load amps (all models)		9.6	8.7	4.4	3.5	
Electric heat full load amps/element (4 min.-10 max. 230V 9 max.)		31.3	36.1	18.0	14.4	

DMS3-415 CHILLED WATER, GAS, HOT WATER AND STEAM HEAT ELECTRICAL DATA

Voltage (three phase)	Without Return Air Blower					With Return Air Blower				
	Supply Air Blower Motor hp	Gas, Steam or Hot Water Heat & Chilled Water Minimum Circuit Ampacity	Gas, Steam or Hot Water Heat & Air Conditioning Minimum Circuit Ampacity			Return Air Blower Motor hp	Gas, Steam or Hot Water Heat & Chilled Water Minimum Circuit Ampacity	Gas, Steam or Hot Water Heat & Air Conditioning Minimum Circuit Ampacity		
			Disc. (1)	Disc. (2)	*Unit			Disc. (1)	Disc. (2)	*Unit
208	5	30.4	192.2	---	---	1-1/2	36.1	197.9	---	---
						3	41.0	202.8	---	---
						5	47.1	157.5	63.1	208.9
	7-1/2	39.8	199.7	---	---	1-1/2	45.5	205.4	---	---
						3	50.4	158.9	63.1	209.9
						5	56.5	165.0	63.1	216.4
	10	48.1	206.3	---	---	1-1/2	53.8	160.6	63.1	212.0
						3	58.7	165.5	63.1	216.9
						5	64.8	171.6	63.1	223.0
	15	67.4	170.3	63.1	221.7	1-1/2	73.1	176.0	63.1	227.4
						3	78.0	180.9	63.1	232.3
						5	84.1	187.0	63.1	238.4
230	5	27.7	188.6	---	---	1-1/2	32.9	193.8	---	---
						3	37.3	198.2	---	---
						5	42.9	203.8	---	---
	7-1/2	36.2	195.4	---	---	1-1/2	41.4	200.6	---	---
						3	45.8	205.0	---	---
						5	51.4	159.6	62.7	210.6
	10	43.7	201.4	---	---	1-1/2	48.9	206.6	---	---
						3	53.3	160.0	62.7	211.0
						5	58.9	165.6	62.7	216.6
	15	61.2	164.4	62.7	215.4	1-1/2	66.4	169.6	62.7	220.6
						3	70.8	174.0	62.7	225.0
						5	76.4	179.6	62.7	230.6
460	5	13.9	67.7	30.7	92.7	1-1/2	16.5	70.3	30.7	95.3
						3	18.7	72.5	30.7	97.5
						5	21.5	75.3	30.7	100.3
	7-1/2	18.2	71.1	30.7	96.1	1-1/2	20.8	73.7	30.7	98.7
						3	23.0	75.9	30.7	100.9
						5	25.8	78.7	30.7	103.7
	10	21.9	74.1	30.7	99.1	1-1/2	24.5	76.7	30.7	101.7
						3	26.7	78.9	30.7	103.9
						5	29.5	81.7	30.7	106.7
	15	30.6	81.0	30.7	106.1	1-1/2	33.2	83.7	30.7	108.7
						3	35.4	85.9	30.7	110.9
						5	38.2	88.7	30.7	113.7
575	5	11.1	68.3	---	---	1-1/2	13.2	70.4	---	---
						3	15.0	72.2	---	---
						5	17.2	74.4	---	---
	7-1/2	14.7	71.2	---	---	1-1/2	16.8	73.3	---	---
						3	18.6	75.1	---	---
						5	20.8	77.3	---	---
	10	17.3	73.2	---	---	1-1/2	19.4	75.3	---	---
						3	21.2	77.1	---	---
						5	23.4	79.3	---	---
	15	24.7	79.2	---	---	1-1/2	26.8	81.3	---	---
						3	28.6	83.1	---	---
						5	30.8	85.3	---	---
						7-1/2	33.7	88.2	---	---

NOTE Refer to National Electrical Code manual to determine wire, fuse and disconnect size requirements. Use wires suitable for at least 75C (167F).
*Single Power Supply.

DMS3-600 DX COOLING AND ELECTRIC HEAT ELECTRICAL DATA

Voltage (three phase)		208V	230V	460V	575V		
Compressor 1	Full Load Amps	70.0	66.0	33.0	26.4		
	Power Factor	.85	.85	.85	.85		
	Locked Rotor Amps	412.0	375.0	188.0	151.0		
Compressors 2 & 3	Full Load Amps (each)	67.0	64.3	32.1	25.7		
	Power Factor	.85	.85	.85	.85		
	Locked Rotor Amps (each)	398.0	361.0	181.0	144.0		
Condenser Fan Motors	Full Load Amps (each)	4.7	4.3	2.2	1.7		
	Horsepower	(4) - 1	(4) - 1	(4) - 1	(4) - 1		
Supply Air Blower Motor	5 hp	Full Load Amps	16.7	15.2	7.6	6.1	
		Locked Rotor Amps	101.0	92.0	46.0	37.0	
	7-1/2 hp	Full Load Amps	24.2	22.0	11.0	9.0	
		Locked Rotor Amps	155.0	150.0	75.0	56.0	
	10 hp	Full Load Amps	30.8	28.0	14.0	11.0	
		Locked Rotor Amps	194.0	175.0	88.0	70.0	
	15 hp	Full Load Amps	46.2	42.0	21.0	17.0	
		Locked Rotor Amps	264.0	240.0	120.0	96.0	
	Return Air Blower Motor	1-1/2 hp	Full Load Amps	5.7	5.2	2.6	2.1
			Locked Rotor Amps	44.0	31.6	15.8	12.8
		3 hp	Full Load Amps	10.6	9.6	4.8	3.9
			Locked Rotor Amps	70.0	64.0	32.0	26.0
5 hp		Full Load Amps	16.7	15.2	7.6	6.1	
		Locked Rotor Amps	101.0	92.0	46.0	37.0	
7-1/2 hp		Full Load Amps	24.2	22.0	11.0	9.0	
		Locked Rotor Amps	155.0	150.0	75.0	56.0	
2 KVA transformer full load amps (all models)		9.6	8.7	4.4	3.5		
Electric heat full load amps/element (4 min. - 10 max. 230V 9 max.)		31.3	36.1	18.0	14.4		

DMS3-600 CHILLED WATER, GAS, HOT WATER AND STEAM HEAT ELECTRICAL DATA

Voltage (three phase)	Without Return Air Blower					With Return Air Blower				
	Supply Air Blower Motor hp	Gas, Steam or Hot Water Heat & Chilled Water Minimum Circuit Ampacity	Gas, Steam or Hot Water Heat & Air Conditioning Minimum Circuit Ampacity			Return Air Blower Motor hp	Gas, Steam or Hot Water Heat & Chilled Water Minimum Circuit Ampacity	Gas, Steam or Hot Water Heat & Air Conditioning Minimum Circuit Ampacity		
			Disc. (1)	Disc. (2)	*Unit			Disc. (1)	Disc. (2)	*Unit
208	5	30.4	114.8	168.6	266.6	1-1/2	36.1	120.5	168.6	272.3
						3	41.0	125.4	168.6	277.2
						5	47.1	131.5	168.6	283.3
	7-1/2	39.8	122.3	168.6	274.1	1-1/2	45.5	128.0	168.6	279.8
						3	50.4	132.9	168.6	284.7
						5	56.5	139.0	168.6	290.8
	10	48.1	128.9	168.6	280.7	1-1/2	53.8	134.6	168.6	286.4
						3	58.7	139.5	168.6	291.3
						5	64.8	145.6	168.6	297.4
	15	67.4	144.3	168.6	296.1	1-1/2	73.1	150.0	168.6	301.8
						3	78.0	154.9	168.6	306.7
						5	84.1	161.0	168.6	312.8
230	5	27.7	108.6	159.7	252.2	7-1/2	91.6	168.5	168.6	320.3
						1-1/2	32.9	113.8	159.7	256.8
						3	37.3	118.2	159.7	261.8
	7-1/2	36.2	115.4	159.7	259.0	5	42.9	123.8	159.7	267.4
						1-1/2	41.4	120.6	159.7	264.2
						3	45.8	125.0	159.7	268.6
	10	43.7	121.4	159.7	265.0	5	51.4	130.6	159.7	274.2
						1-1/2	48.9	126.6	159.7	270.2
						3	53.3	131.0	159.7	274.6
	15	61.2	135.4	159.7	279.0	5	58.9	136.6	159.7	280.2
						1-1/2	66.4	140.6	159.7	284.2
						3	70.8	145.0	159.7	288.6
460	5	13.9	54.3	79.9	126.2	5	76.4	150.6	159.7	294.2
						7-1/2	83.2	157.4	159.7	301.0
						1-1/2	16.5	56.9	79.9	128.8
	7-1/2	18.2	57.7	79.9	129.6	3	18.7	59.1	79.9	131.0
						5	21.5	61.9	79.9	133.8
						1-1/2	20.8	60.3	79.9	132.2
	10	21.9	60.7	79.9	132.6	3	23.0	62.5	79.9	134.4
						5	25.8	65.3	79.9	137.2
						1-1/2	24.5	63.3	79.9	135.2
	15	30.6	67.7	79.9	139.6	3	26.7	65.5	79.9	137.4
						5	29.5	68.3	79.9	140.2
						1-1/2	33.2	70.3	79.9	142.2
575	5	11.1	43.4	63.8	100.8	3	35.4	72.5	79.9	144.4
						5	38.2	75.3	79.9	147.2
						7-1/2	41.6	78.7	79.9	150.6
	7-1/2	14.7	46.3	63.8	103.7	1-1/2	13.2	45.5	63.8	102.9
						3	15.0	47.3	63.8	104.7
						5	17.2	49.5	63.8	106.9
	10	17.3	48.3	63.8	105.7	1-1/2	16.8	48.4	63.8	105.8
						3	18.6	50.2	63.8	107.6
						5	20.8	52.4	63.8	109.8
	15	24.7	54.3	63.8	111.7	1-1/2	19.4	50.4	63.8	107.8
						3	21.2	52.2	63.8	109.6
						5	23.4	54.4	63.8	111.8
					1-1/2	26.8	56.4	63.8	113.8	
					3	28.6	58.2	63.8	115.6	
					5	30.8	60.4	63.8	117.8	
					7-1/2	33.7	63.3	63.8	120.7	

NOTE - Refer to National Electrical Code manual to determine wire, fuse and disconnect size requirements. Use wires suitable for at least 75C (167F). *Single Power Supply.

BLOWER DATA

BLOWER DRIVE SELECTION

Using total air volume (cfm) and system Static Pressure External to Unit (inches water gauge) requirements determine from Blower Performance Chart Rpm and Bhp required for job. Specify Bhp, exact

Rpm and power characteristics required when ordering. The correct motor and pulleys will be factory installed. The following tables list Motor hp and Rpm range of the drive setups available with each motor.

RETURN AIR BLOWER

Nominal Motor hp	Maximum Usable hp	*Rpm Range Of All Available Drive Setups @1720 Rpm Motor Speed
1-1/2	1.72	330-430
3	3.45	445-545
5	5.75	550-665
7-1/2	8.62	660-795

SUPPLY AIR BLOWER

Nominal Motor hp	Maximum Usable hp	*Rpm Range Of All Available Drive Setups @1720 Rpm Motor Speed
5	5.75	515-735
7-1/2	8.63	680-900
10	11.5	680-900
15	17.25	785-1100

NOTE—The maximum usable hp of motors furnished by Lennox are shown in table. If other motors of comparable hp are used be sure to keep within the service factor limitations outlined on the motor nameplate.

*Specify exact Bhp, Rpm and power characteristics required when ordering unit.

MINIMUM HORSEPOWER REQUIREMENTS AS REQUIRED BY A.G.A.

Gas Input (Btuh)	Minimum Supply Air Blower Motor Required	*Minimum Return Air Blower Motor Required
350,000	5 hp	1-1/2 hp
500,000	5 hp	1-1/2 hp
700,000	7-1/2 hp	3 hp
850,000	10 hp	3 hp

* Return air blower is optional and not required in all applications.

PRESSURE DROP OF OPTIONAL FILTERS

Air Volume (cfm)	*Filter Pressure Drop (inches water gauge)			Roll Filter
	55% efficiency	85% efficiency	95% efficiency	
9,000	.24	.32	.35	.06
10,000	.25	.33	.37	.08
10,500	.26	.34	.39	.09
11,000	.28	.36	.42	.10
11,500	.30	.39	.45	.11
12,000	.32	.41	.47	.11
12,500	.34	.44	.50	.12
13,000	.37	.47	.53	.14
13,500	.38	.49	.56	.14
14,000	.41	.52	.59	.16
14,500	.43	.55	.62	.16
15,000	.46	.58	.65	.17
16,000	.49	.63	.72	.20
17,000	.54	.69	.80	.23
18,000	.60	.76	.89	.25

*When optional filters are used pressure drop shown must be added to system resistance when selecting RPM & BHP requirements.

NOTE—Frame filter resistance has been deducted from figures shown in table.

BLOWER DATA

DMS3-415-600 SUPPLY AIR BLOWER PERFORMANCE

Air Volume (Cfm)	STATIC PRESSURE EXTERNAL TO UNIT (Inches Water Gauge)																					
	0		.10		.20		.30		.40		.50		.60		.70		.80		.90		1.00	
	RPM	BHP	RPM	BHP	RPM	BHP	RPM	BHP	RPM	BHP	RPM	BHP	RPM	BHP	RPM	BHP	RPM	BHP	RPM	BHP	RPM	BHP
9000	---	---	---	---	---	---	---	540	2.4	570	2.7	595	3.0	620	3.2	650	3.5	675	3.7	700	4.0	
9500	---	---	---	---	---	530	2.5	560	2.7	590	3.0	615	3.3	640	3.5	665	3.8	690	4.0	715	4.3	
10,000	---	---	---	---	520	2.6	550	2.8	575	3.1	605	3.4	630	3.7	655	3.9	680	4.2	705	4.4	730	4.7
10,500	---	---	515	2.7	540	3.0	570	3.2	600	3.5	625	3.8	650	4.1	675	4.4	700	4.6	720	4.9	745	5.2
11,000	---	---	535	3.2	560	3.4	590	3.7	615	3.9	640	4.2	665	4.5	690	4.8	710	5.1	740	5.4	760	5.7
11,500	535	3.4	560	3.6	585	3.9	610	4.1	635	4.4	660	4.6	685	4.9	705	5.2	730	5.6	750	5.9	775	6.2
12,000	560	3.9	585	4.1	610	4.4	630	4.6	655	4.9	680	5.1	700	5.4	725	5.7	750	6.1	770	6.4	790	6.7
12,500	585	4.4	610	4.6	630	4.9	655	5.1	675	5.4	700	5.6	720	5.9	740	6.3	760	6.6	785	7.0	805	7.3
13,000	605	5.0	630	5.2	650	5.5	675	5.7	695	6.0	720	6.2	740	6.5	760	6.9	780	7.2	800	7.6	820	7.9
13,500	630	5.6	650	5.8	675	6.1	695	6.3	720	6.6	740	6.8	760	7.1	780	7.5	800	7.8	820	8.2	840	8.5
14,000	650	6.1	670	6.4	695	6.6	715	6.9	740	7.1	760	7.4	780	7.7	800	8.1	815	8.5	835	8.8	855	9.2
14,500	675	6.6	695	6.9	715	7.2	740	7.5	760	7.9	780	8.2	800	8.6	815	8.9	835	9.3	850	9.6	870	10.0
15,000	700	7.2	720	7.6	740	8.0	760	8.3	780	8.7	800	9.1	820	9.5	835	9.8	855	10.2	870	10.5	890	10.9
16,000	740	8.9	760	9.3	780	9.7	800	10.1	820	10.4	840	10.8	860	11.2	875	11.6	890	12.0	905	12.3	920	12.6
17,000	780	10.7	800	11.1	820	11.5	840	11.9	860	12.2	880	12.6	895	13.0	910	13.4	925	13.8	940	14.1	955	14.4
18,000	820	12.5	840	12.9	860	13.3	880	13.7	900	14.1	915	14.5	930	14.9	945	15.3	960	15.6	975	15.9	990	16.2

NOTE—The above chart is based on the maximum HP condition of zone dampers in the intermediate position, standard frame filters and 20% outside air. Return air blower is not included. For full cooling or full heating, CFM will be reduced approximately 7%.

RETURN AIR BLOWER PERFORMANCE (1-1/2, 3 & 5 hp Motors)

Air Volume (Cfm)	STATIC PRESSURE EXTERNAL TO UNIT – (Return Air System) – (Inches Water Gauge)																					
	0		.10		.20		.30		.40		.50		.60		.70		.80		.90		1.00	
	RPM	BHP	RPM	BHP	RPM	BHP	RPM	BHP	RPM	BHP	RPM	BHP	RPM	BHP	RPM	BHP	RPM	BHP	RPM	BHP	RPM	BHP
5000	---	---	---	---	---	---	---	360	.7	390	.9	420	1.2	450	1.5	475	1.8	500	2.0	520	2.2	
6000	---	---	---	---	---	350	.6	385	.9	415	1.1	440	1.4	470	1.7	495	2.0	520	2.2	540	2.4	
7000	---	---	---	---	340	.6	375	.8	410	1.1	440	1.3	465	1.6	490	1.9	515	2.2	540	2.4	555	2.7
8000	---	---	335	.6	370	.8	400	1.0	430	1.3	460	1.5	485	1.8	510	2.1	535	2.4	555	2.6	570	2.9
9000	350	.7	370	.8	395	1.0	425	1.2	455	1.5	480	1.7	505	2.0	530	2.3	555	2.6	575	2.9	590	3.2
10,000	385	1.0	405	1.1	430	1.3	455	1.5	485	1.8	510	2.1	530	2.4	555	2.7	580	3.0	600	3.4	615	3.7
11,000	425	1.3	440	1.4	460	1.6	485	1.8	510	2.1	540	2.5	560	2.8	580	3.1	600	3.5	620	3.9	640	4.3
12,000	460	1.6	475	1.7	490	1.9	520	2.2	540	2.5	565	2.8	585	3.2	605	3.5	625	3.9	645	4.4	665	4.8
13,000	500	2.0	510	2.2	525	2.4	550	2.6	570	2.9	590	3.2	610	3.6	630	4.0	650	4.4	---	---	---	---
14,000	540	2.5	550	2.7	560	2.9	585	3.1	600	3.4	620	3.8	640	4.3	660	4.4	---	---	---	---	---	---
15,000	575	3.0	590	3.2	600	3.4	620	3.7	635	4.0	655	4.5	---	---	---	---	---	---	---	---	---	---

RETURN AIR BLOWER PERFORMANCE (7-1/2 hp Motor)

Air Volume (Cfm)	STATIC PRESSURE EXTERNAL TO UNIT – (Return Air System) – (Inches Water Gauge)																					
	0		.10		.20		.30		.40		.50		.60		.70		.80		.90		1.00	
	RPM	BHP	RPM	BHP	RPM	BHP	RPM	BHP	RPM	BHP	RPM	BHP	RPM	BHP	RPM	BHP	RPM	BHP	RPM	BHP	RPM	BHP
13,000	---	---	---	---	---	---	---	---	---	---	---	---	---	---	---	---	---	665	4.7	680	5.2	
14,000	---	---	---	---	---	---	---	---	---	---	---	---	---	---	665	4.5	680	5.0	695	5.4	710	5.8
15,000	---	---	---	---	---	---	---	---	---	---	---	---	---	---	---	---	---	---	---	---	---	---
16,000	---	---	---	---	---	---	---	---	---	---	---	---	---	---	665	4.3	680	4.7	695	5.1	710	5.6
17,000	---	---	---	---	---	---	---	---	---	---	---	---	---	---	695	5.0	710	5.4	725	5.8	740	6.3
18,000	690	4.3	705	4.7	720	5.2	735	5.6	750	6.0	765	6.5	780	7.0	795	7.4	---	---	---	---	---	---

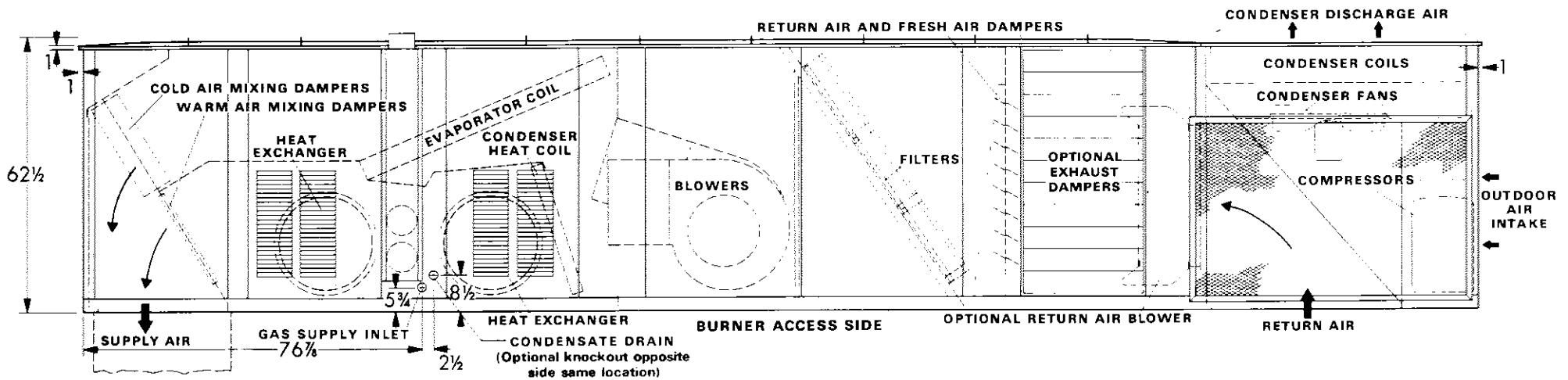
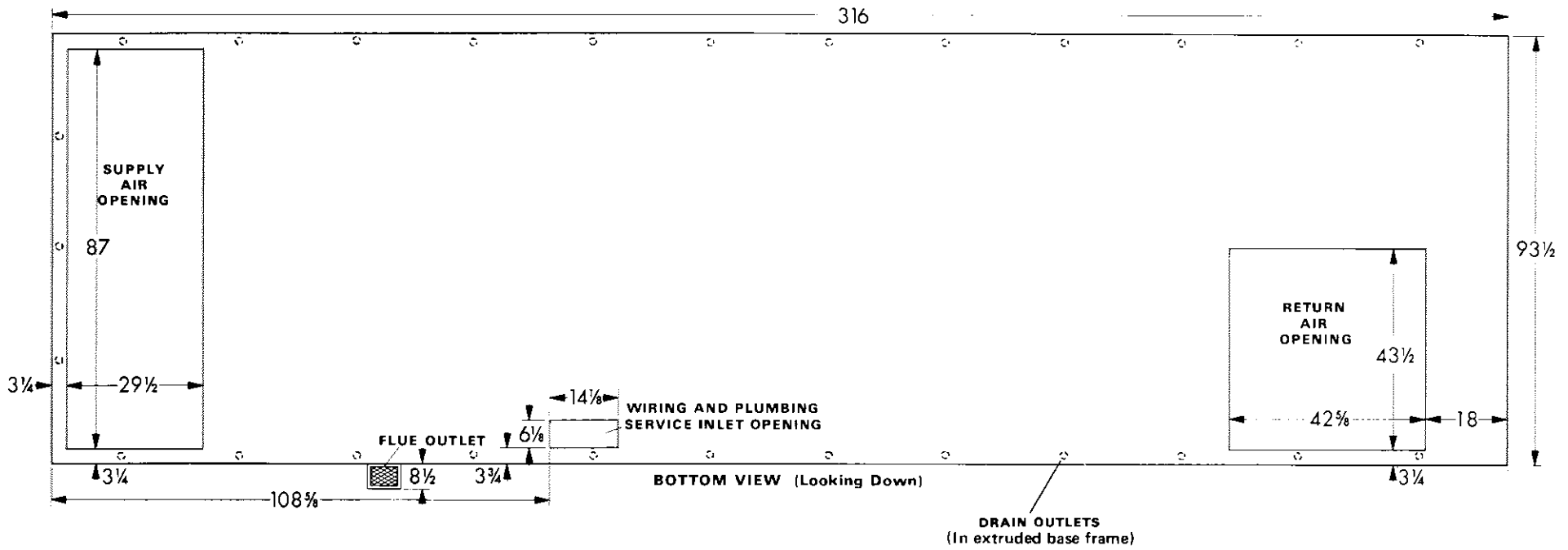

DIMENSIONS (inches)

SUPPLY AIR CONNECTIONS

NOTE—12 zone maximum air volume per zone is 1500 cfm.
18 zone maximum air volume per zone is 1000 cfm.

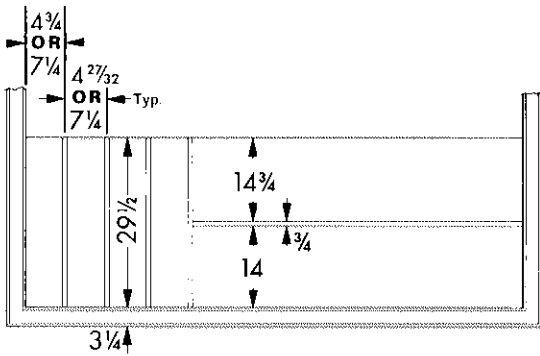

**DUAL DUCT SPLITTER
SUPPLY AIR CONNECTIONS FOR COMBINATION
ZONE AND DOUBLE DUCT APPLICATIONS**

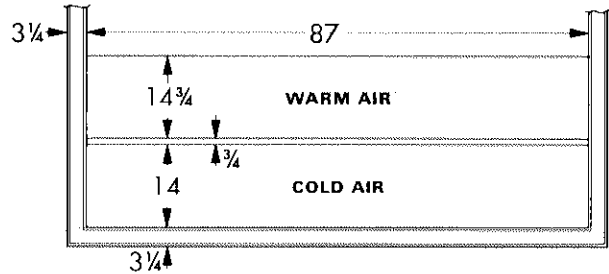

**SUPPLY AIR CONNECTIONS FOR
DOUBLE DUCT APPLICATIONS**

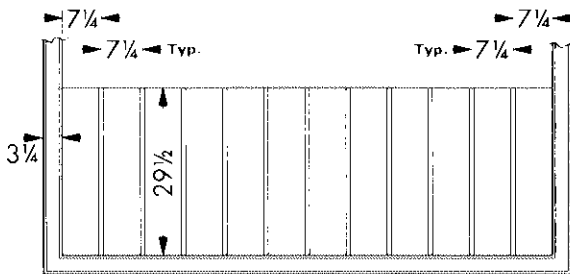

**SUPPLY AIR CONNECTIONS
FOR 12 OR LESS ZONES**

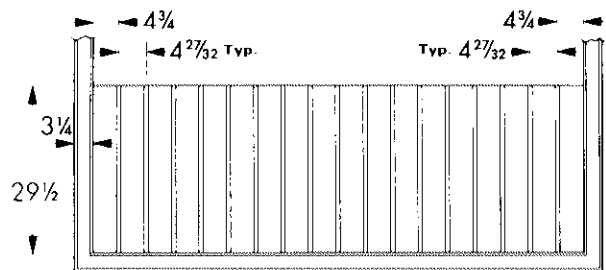

**SUPPLY AIR CONNECTIONS
FOR 18 OR LESS ZONES**

Supply Air Plenums

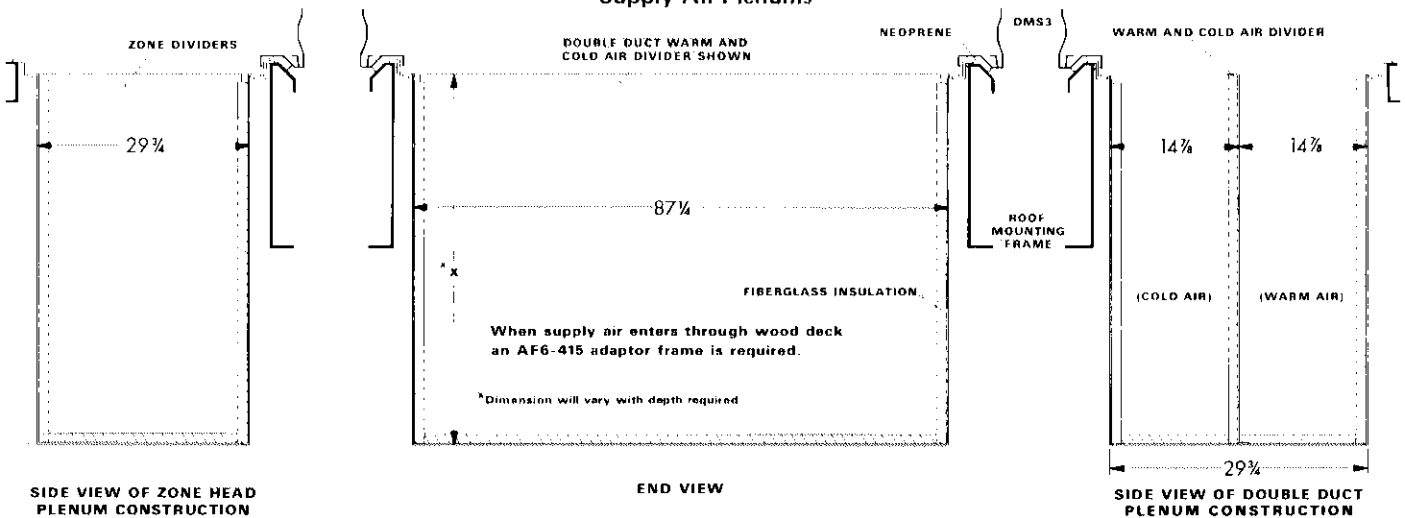

**SIDE VIEW OF ZONE HEAD
PLENUM CONSTRUCTION**

END VIEW

**SIDE VIEW OF DOUBLE DUCT
PLENUM CONSTRUCTION**

ROOF MOUNTING FRAME (12 or 18 ZONE HEAD & DOUBLE DUCT)

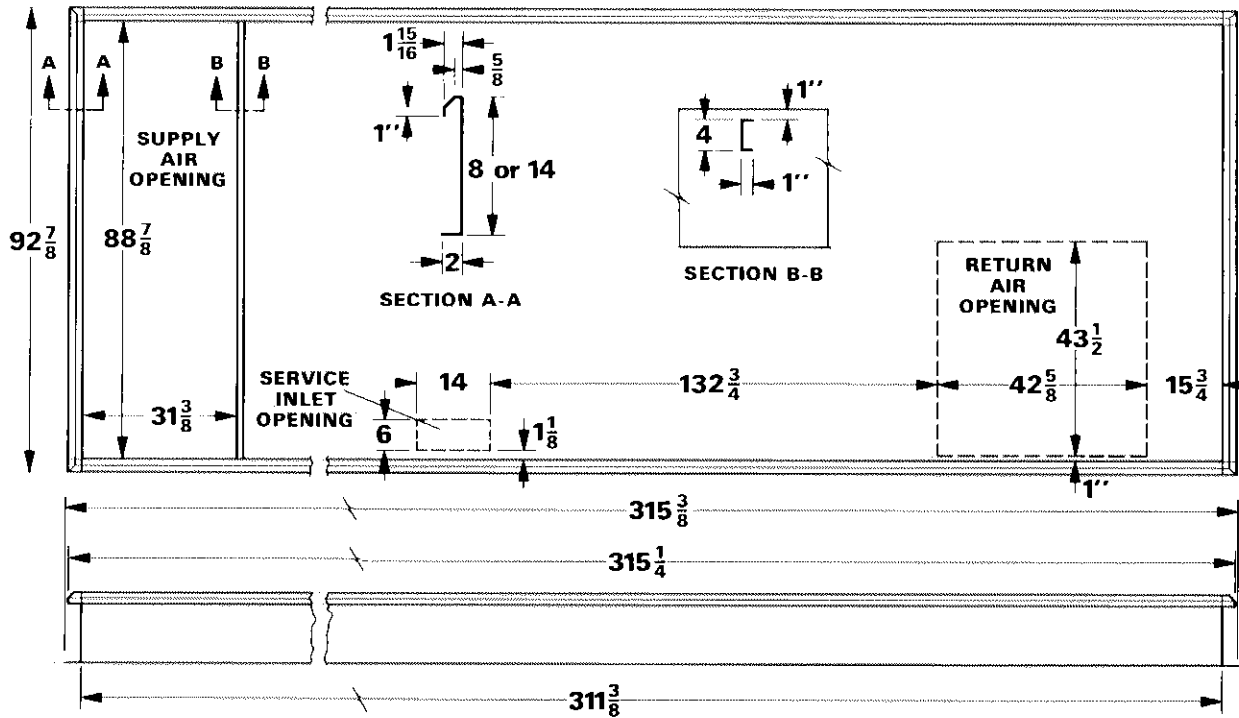

APPLICATION AND SYSTEM DESIGN

This *Application and System Design* section outlines some basic application data and installation hints which should be followed. Consideration should be given to roof loading, roof flashing, clearances, sound treatment and volume dampers.

Roofmounting Frame

Mounting frames are shipped knocked down in a compact package for ease in transportation and lifting to the rooftop. Bolts and rugged joint plates are furnished to secure the sections together at the job site. Holes are provided in the frame sections and joining plates. The entire weight of the unit is transferred uniformly to the mounting frame.

Roofmounting Frame Supports

The roofmounting frame can be installed directly on the deck or setting on the roof supports under the deck. When the frame sets directly on the deck adequate structural strength in the deck is required. When installing the frames on support members under the deck the following support specifications apply:

- 1—With joint plates bolted the maximum frame span between supports is 5 feet.
- 2—With joint plates welded to frame the maximum frame span or cantilever is:

	Span	Cantilever
8" high frame	11 feet	6 feet
14" high frame	16 feet	9 feet

- 3—A bolted joint cannot be included in a cantilever. If the roof mounting frame is cantilevered more than 6 feet the joint plate and frame (closest to the overhang) must be welded.
- 4—There must be at least 32 inches of frame in contact with the roof supports.

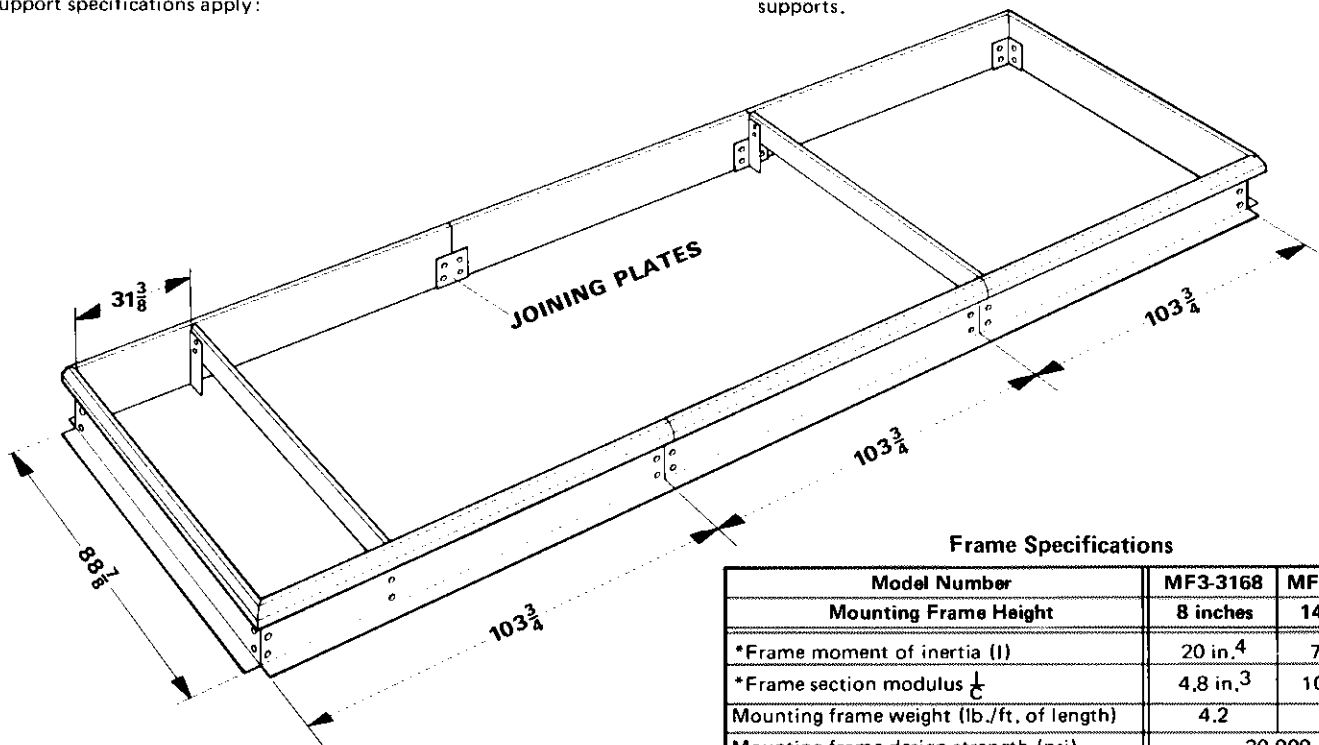

Frame Specifications

Model Number	MF3-3168	MF3-31614
Mounting Frame Height	8 inches	14 inches
*Frame moment of inertia (I)	20 in. ⁴	77 in. ⁴
*Frame section modulus $\frac{I}{c}$	4.8 in. ³	10.7 in. ³
Mounting frame weight (lb./ft. of length)	4.2	6.1
Mounting frame design strength (psi)	20,000	

*Includes both sides of roof mounting frame (MF3).

ROOF MOUNTING FRAME

APPROVED BY NATIONAL ROOFING CONTRACTORS ASSOCIATION

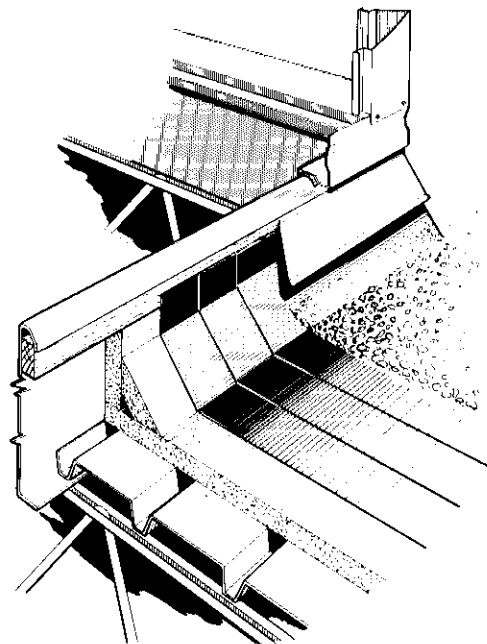
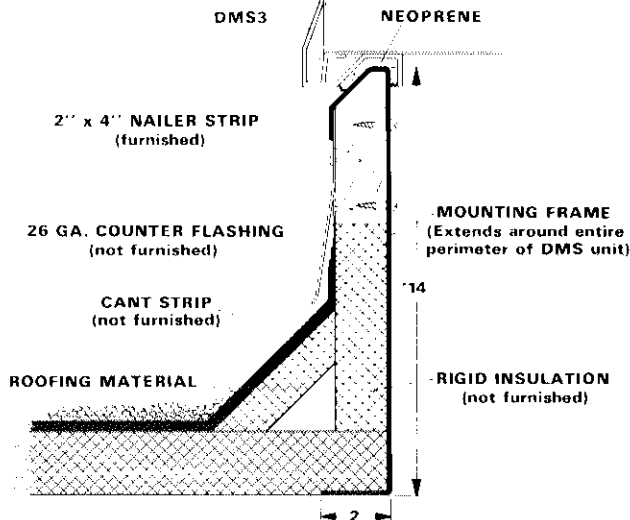

*An 8" high frame is also available for special applications. It is not NRCA approved.

Net Weights, Center of Gravity and Corner Weights

Components		Total Net Weight (lbs.)	Moment in "X" Direction	Moment in "Y" Direction
Basic unit		2940	592,000	+7000
*12 or 18 zone mounting frame		475	65,100	0
*AF6-415 combustible adaptor frame		45	---	---
Blower Motor & Drives	5 hp	75	10,000	+2000
	7-1/2 hp	90	12,000	+3000
	10 hp & 15 hp	130	18,000	+4000
Heating Options	1 gas heat exchanger	415	23,000	+8000
	2 gas heat exchanger	660	45,000	+10,000
	Electric section	460	30,000	+9000
	Hot water coil	270	15,000	+2000
	Steam coil	185	10,000	-1000
DX Cooling	Evaporator only	375	35,000	-2000
	Complete System (415)	2240	515,000	-3000
	Complete System (600)	2490	533,000	-27,000
Chilled Water Cooling	Four row coil	460	43,000	-2000
	Six row coil	560	53,000	-3000
POWER SAVER System		55	11,000	+1000
Filters	Frame or bag	125	22,000	0
	Roll	315	55,000	0
Return air blower		270	66,000	+8000
Distribution Head	12 Zone (E.P.)	675	9,000	0
	12 Zone (MOD.)	760	10,000	0
	18 Zone (E.P.)	820	11,000	0
	18 Zone (MOD.)	915	12,000	0
	Double Duct	300	5,000	0
*SE1-86 Service Enclosure		344	---	---
*SEK1-87-33 Service Enclosure Kit		47	---	---

*Do not include in hoisting weight. Moment is in inch lbs.

MOD. = Modulating damper motor (Each motor weighs 9 lbs.)
E.P. = Electrical proportioning damper motor.

How to calculate center of gravity:

- 1—Add up System Component wts. to arrive at **Total Net Wt.**
- 2—Add up **Moment** in "X" Direction figures to arrive at a total.
- 3 Add up **Moment** in "Y" Direction figures to arrive at a total.
- 4—Divide total **Moment** in "X" Direction by **Total Wt.** to obtain "X".
- 5—Divide total **Moment** in "Y" Direction by **Total Wt.** to obtain "Y" Dimension.

How to calculate corner weights:

$$A = (\text{Wt. of unit}) \frac{(316 - X)(47 + Y)}{30,000}$$

$$B = (\text{Wt. of unit}) \frac{(316 - X)(47 - Y)}{30,000}$$

$$C = (\text{Wt. of unit}) \frac{X(47 - Y)}{30,000}$$

$$D = (\text{Wt. of unit}) \frac{X(47 + Y)}{30,000}$$

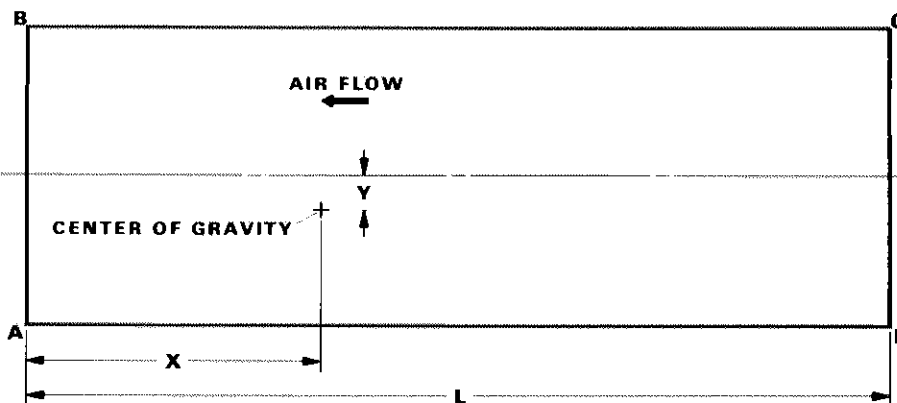

APPLICATION AND SYSTEM DESIGN

RETURN AIR SYSTEMS, ACOUSTICAL TREATMENT AND VOLUME DAMPERS

Return Air

Return air systems are generally one of two types:

- 1—Ducted return air system
- 2—Open plenum return air system (Sandwich space)

The ducted return air system offers the feature of lining the duct with insulation giving the ultimate in acoustical treatment.

The open plenum system eliminates the cost of return air ducts and is extremely flexible. In a building with relocatable interior walls it is much easier to change the location of a ceiling grille than reroute a ducted return system.

Acoustical Treatment

It is recommended to insulate the supply duct to reduce duct loss or gain and to prevent condensation. Use 1-1/2 lbs. density on ducts which deliver air velocities up to 1500 fpm.

3 lb. density or neoprene coated is recommended for ducts which handle air at velocities greater than 1500 fpm. Insulation can be 1/2" or 1" thick and can be on the outside or inside of the duct.

Where any rooftop equipment utilizes the sandwich space for the return air system a return air chamber such as shown below should be connected to the air inlet opening. This reduces air handling sound transmission through the thin ceiling panels. It should be sized not to exceed 1500 fpm return air velocity. It can be of fiberglass duct or fiberglass lined metal duct. It is recommended not to install a ceiling return air grille within 15' of the duct inlet. The illustration below is just one recommended way to build an acoustical trap and has been used with good results.

Volume Dampers

Volume dampers are important to good system design. Lengths of supply runs vary and are usually of the same cubics, therefore balancing dampers should be used in each supply branch run. Balancing dampers are furnished and factory installed on the zone model units. The dampers are located in each zone at the air discharge end of the unit at bottom of the air outlet. The installer must furnish and install the balancing dampers for double duct applications. Dampers should be installed between mixing box and diffuser outlet.

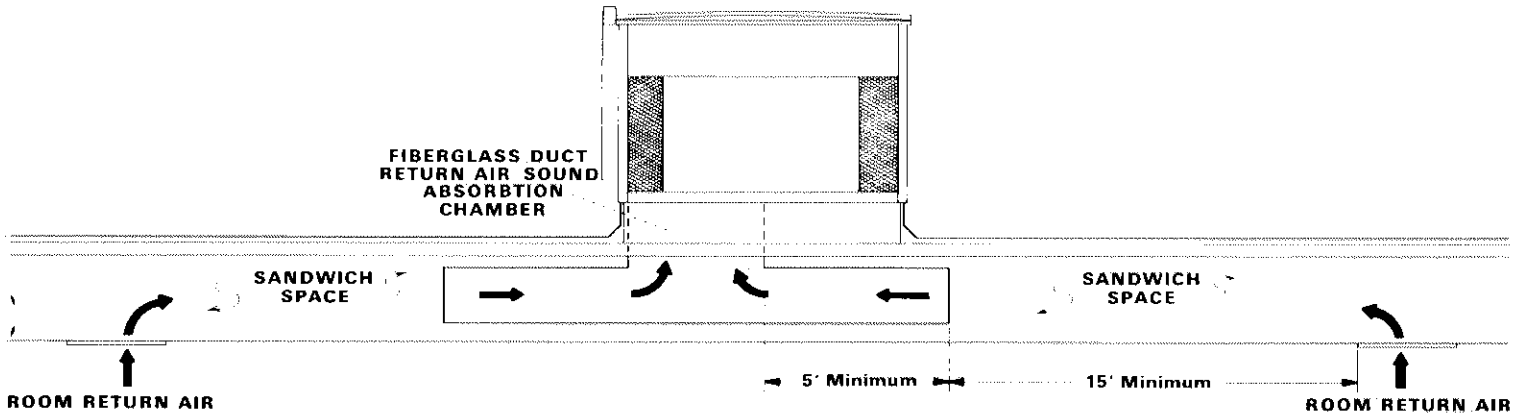

TYPICAL APPLICATIONS

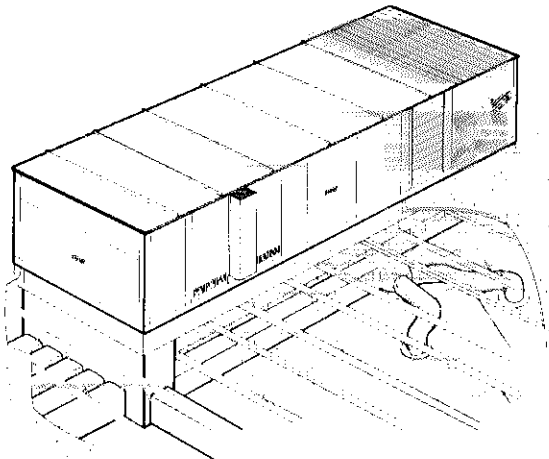

12 or 18 zone distribution system.

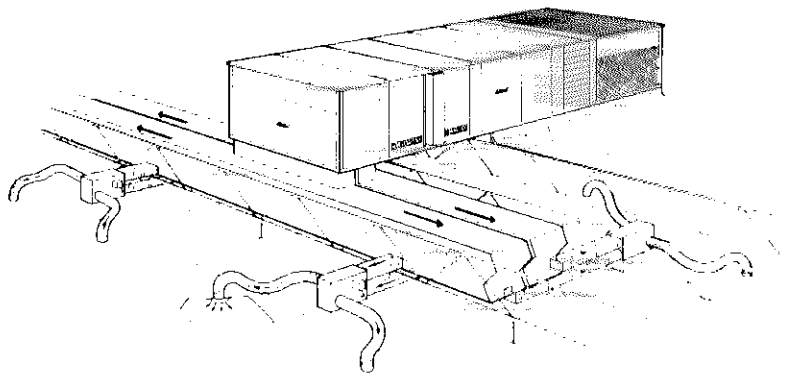

Double duct distribution system with zone damper boxes.

SERVICE CLEARANCES

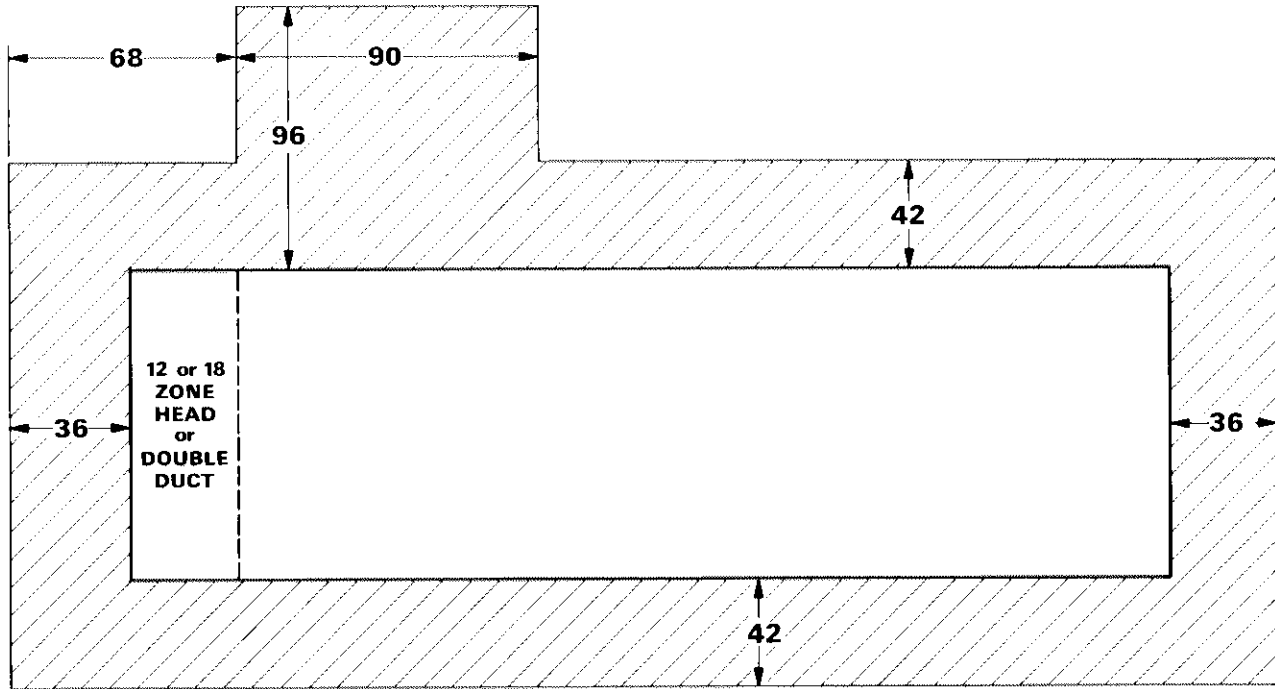

STEAM DATA

STEAM HEATING CAPACITY

Air Volume (CFM)	Steam Pressure									
	25 PSI		15 PSI		10 PSI		5 PSI		0 PSI	
	TR	Btuh	TR	Btuh	TR	Btuh	TR	Btuh	TR	Btuh
16,000	64.0	1,110,000	58.9	1,020,000	55.5	955,000	51.8	900,000	47.1	820,000
15,000	66.2	1,080,000	60.7	990,000	57.2	930,000	53.4	870,000	48.5	790,000
14,000	68.2	1,030,000	62.7	955,000	59.0	895,000	55.0	835,000	50.1	760,000
13,000	70.4	995,000	64.5	910,000	60.9	860,000	56.8	800,000	51.6	730,000
12,000	73.5	955,000	67.5	880,000	63.5	825,000	59.2	770,000	54.0	700,000
11,000	76.5	910,000	70.4	840,000	66.2	790,000	61.8	735,000	56.1	670,000
10,000	80.0	870,000	73.2	795,000	69.0	750,000	64.2	695,000	58.5	635,000
9,000	84.0	820,000	77.0	750,000	72.5	710,000	67.5	660,000	61.5	600,000
8,000	88.0	765,000	80.8	700,000	76.0	660,000	71.0	615,000	64.5	560,000
7,000	93.0	705,000	85.5	650,000	80.5	610,000	75.1	570,000	68.5	510,000
6,000	98.3	640,000	90.4	590,000	85.0	550,000	79.4	515,000	72.1	460,000
5,000	105.8	570,000	97.0	525,000	91.2	495,000	85.1	460,000	77.5	420,000

NOTE - Based on 60F entering air temperature.

STEAM COIL CAPACITY CORRECTION FACTOR CHART

Multiply rating in steam coil capacity chart by correction factor below.

Entering Air Temperature (Degrees F)	*Steam Pressure (psig)				
	0	5	10	15	25
80	0.868	0.880	0.889	0.899	0.903
70	0.934	0.940	0.944	0.950	0.952
60	1.000	1.000	1.000	1.000	1.000
50	1.066	1.060	1.056	1.050	1.048
40	1.132	1.120	1.111	1.101	1.097

NOTE: Leaving Air Temp. = Ent. Air Temp. + $\frac{\text{Btuh Capacity}}{1.08 \times \text{cfm}}$

DMS3-415 REFRIGERANT PIPING

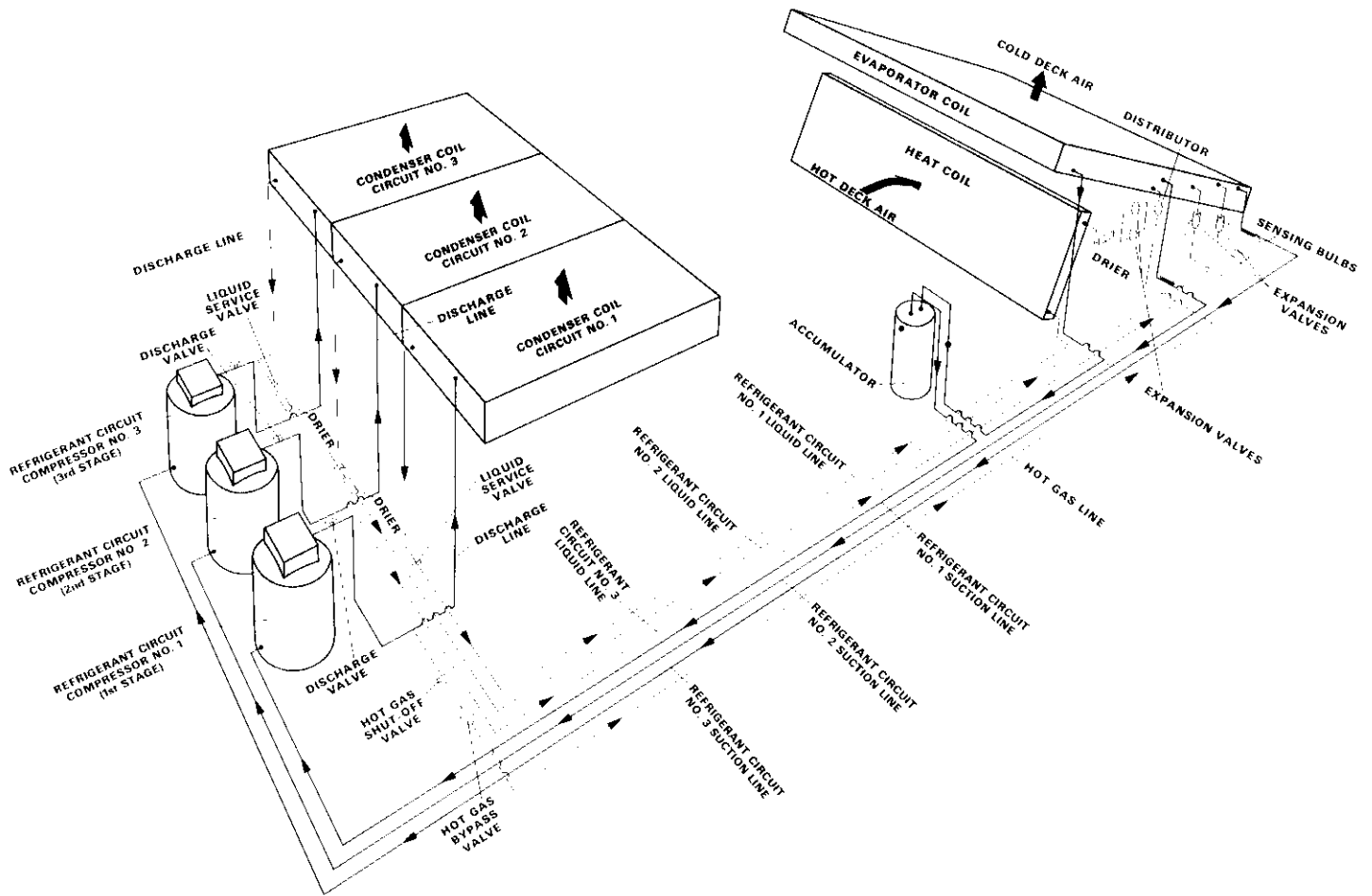

DMS3-600 REFRIGERANT PIPING

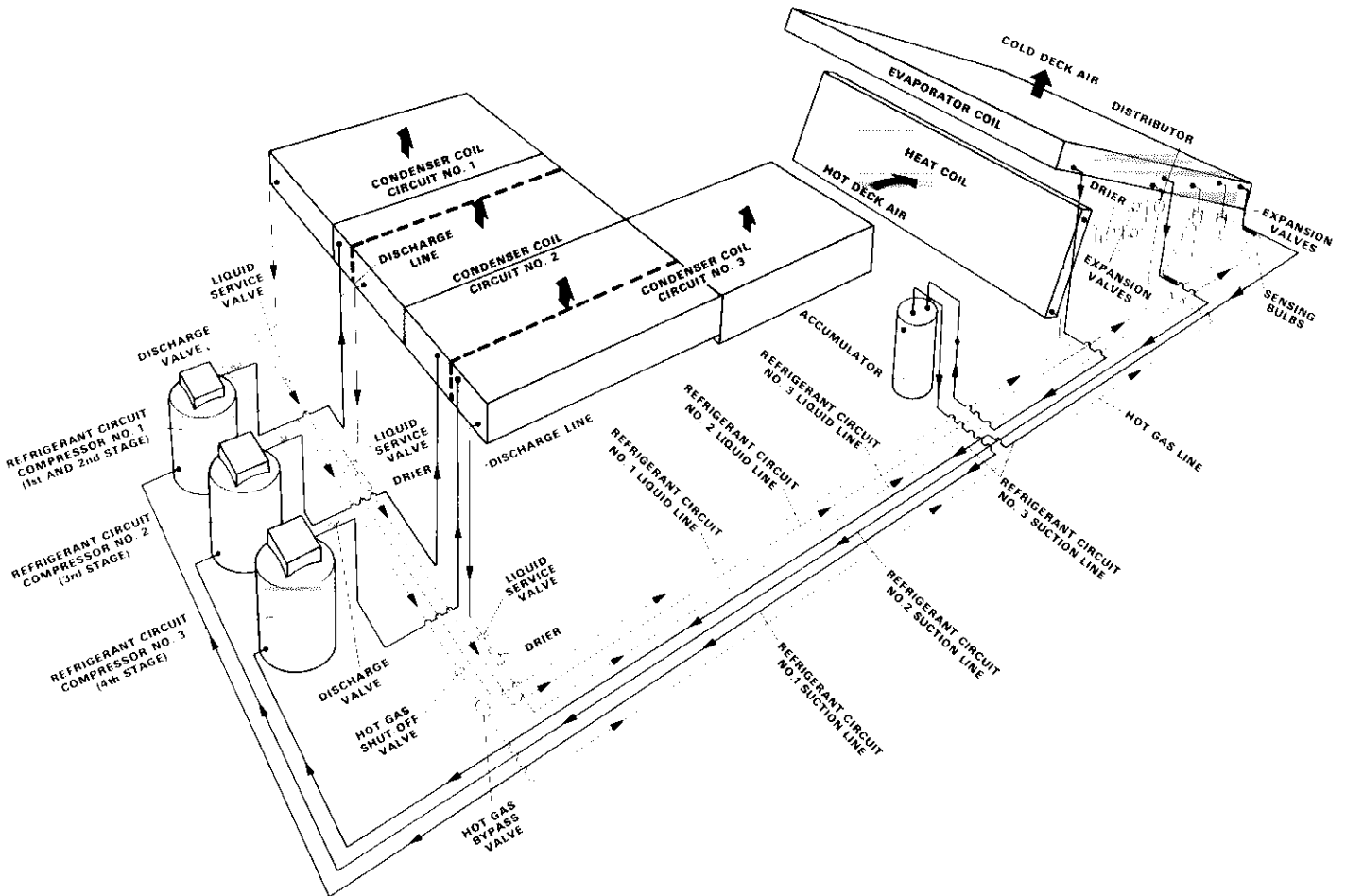

RATINGS

DMS3-415 COOLING CAPACITY

Evaporator Air 80F Dry Bulb		Air Temperature Entering Condenser Coil (F)											
		85			95			105			115		
Entering Wet Bulb (F)	Total Air Volume (CFM)	Total Cooling Capacity (Btuh)	Sensible To Total Ratio (S/T)	Comp. Motor Watts Input	Total Cooling Capacity (Btuh)	Sensible To Total Ratio (S/T)	Comp. Motor Watts Input	Total Cooling Capacity (Btuh)	Sensible To Total Ratio (S/T)	Comp. Motor Watts Input	Total Cooling Capacity (Btuh)	Sensible To Total Ratio (S/T)	Comp. Motor Watts Input
63	12,000	390,900	.87	36,000	369,900	.90	38,310	351,000	.92	40,800	327,000	.96	44,250
	13,500	397,500	.91	36,450	376,500	.94	38,610	357,000	.97	41,250	332,100	1.00	44,550
	15,000	403,500	.95	36,810	382,500	.98	39,000	362,100	1.00	41,550	336,000	1.00	44,850
67	12,000	421,500	.69	37,800	399,000	.71	40,050	378,000	.73	42,750	353,000	.77	46,050
	13,500	429,000	.72	38,100	405,900	.74	40,500	385,500	.76	43,200	359,100	.79	46,500
	15,000	435,000	.74	38,400	411,900	.77	40,800	390,000	.78	43,800	363,000	.82	46,800
71	12,000	453,000	.54	39,300	429,000	.55	41,790	406,500	.56	44,700	379,500	.58	48,000
	13,500	460,500	.55	39,750	438,000	.57	42,150	412,500	.58	45,150	385,500	.60	48,390
	15,000	468,000	.57	40,110	444,000	.58	42,450	418,500	.60	45,510	390,000	.62	48,750

DMS3-600 COOLING CAPACITY

Evaporator Air 80F Dry Bulb		Air Temperature Entering Condenser Coil (F)											
		85			95			105			115		
Entering Wet Bulb (F)	Total Air Volume (CFM)	Total Cooling Capacity (Btuh)	Sensible To Total Ratio (S/T)	Comp. Motor Watts Input	Total Cooling Capacity (Btuh)	Sensible To Total Ratio (S/T)	Comp. Motor Watts Input	Total Cooling Capacity (Btuh)	Sensible To Total Ratio (S/T)	Comp. Motor Watts Input	Total Cooling Capacity (Btuh)	Sensible To Total Ratio (S/T)	Comp. Motor Watts Input
63	12,000	476,000	.81	53,800	458,000	.82	57,300	438,000	.84	62,100	415,000	.86	69,700
	14,000	491,000	.84	55,100	472,000	.86	58,400	450,000	.88	63,300	426,000	.90	70,700
	16,000	504,000	.88	56,000	484,000	.90	59,400	461,000	.92	64,100	436,000	.95	71,500
67	12,000	515,000	.66	56,800	494,000	.67	60,200	471,000	.68	64,900	445,000	.69	72,300
	14,000	530,000	.68	57,900	507,000	.69	61,300	482,000	.71	66,000	455,000	.73	73,000
	16,000	542,000	.71	58,700	518,000	.72	62,000	492,000	.74	66,500	463,000	.76	73,600
71	12,000	554,000	.52	59,600	530,000	.53	62,800	504,000	.54	67,600	475,000	.55	74,500
	14,000	569,000	.54	60,600	544,000	.54	63,800	516,000	.55	68,300	486,000	.57	77,300
	16,000	580,000	.55	61,400	553,000	.56	64,500	525,000	.57	69,500	495,000	.59	79,800

DMS3-600 COOLING CAPACITY (1st Stage—Low Speed Operation)

Evaporator Air 80F Dry Bulb		Air Temperature Entering Condenser Coil (F)								
		65			75			85		
Entering Wet Bulb (F)	Total Air Volume (CFM)	Total Cooling Capacity (Btuh)	Sensible To Total Ratio (S/T)	Compressor Motor Watts Input	Total Cooling Capacity (Btuh)	Sensible To Total Ratio (S/T)	Compressor Motor Watts Input	Total Cooling Capacity (Btuh)	Sensible To Total Ratio (S/T)	Compressor Motor (Btuh)
63	4000	103,000	.86	7700	100,000	.87	7900	97,000	.89	8300
	5000	107,000	.91	7700	103,000	.93	8000	99,000	.95	8400
	6000	109,000	.95	7800	105,000	.97	8100	102,000	.99	8400
67	4000	112,000	.69	7900	108,000	.70	8200	105,000	.71	8500
	5000	116,000	.72	8000	112,000	.74	8300	107,000	.75	8600
	6000	118,000	.75	8000	114,000	.77	8300	109,000	.78	8700
71	4000	121,000	.54	8100	117,000	.55	8400	112,000	.58	8800
	5000	124,000	.56	8200	120,000	.57	8500	115,000	.58	8800
	6000	126,000	.58	8200	121,000	.59	8500	116,000	.60	8900

GUIDE SPECIFICATIONS

Prepared for the guidance of architects, consulting engineers and mechanical contractors.

General—Furnish and install a roof mounted multizone (heating or heating-cooling unit) with all controls, ducts and zone dampers. The Multizone system shall be a standard product of a firm regularly engaged in manufacture of heating-cooling equipment. The manufacturer shall have parts and service available throughout the United States and Canada.

Roof Mounting Frame—A hot dipped galvanized steel mounting frame shall be furnished. It shall conform exactly to the shape of the system and contoured to accept the base of the equipment. Flashing shall be the responsibility of a roofing contractor. The 14" high frame shall be approved by National Roofing Contractors Association.

Air Distribution—Shall be (double duct with remote zone dampers or zone dampers located at the unit or a combination of both, dual duct splitter).

All air distribution ducts shall be fiberglass or ga. galvanized steel insulated with inch thick lb. density fiberglass or equivalent.

Balancing dampers shall be located at each zone outlet and be equipped with locking devices.

DX Cooling System—The total certified cooling capacity shall not be less than Btuh with an evaporator air volume of cfm, an entering wet bulb air temperature of F and outdoor air db temperature of F. The compressor power input shall not exceed Kw at these conditions.

The coils shall be non-ferrous construction with aluminum fins mechanically bonded to seamless copper tubes. All coils shall be factory pressure leak tested at 450-500 psi.

The system shall consist of (3) totally independent refrigeration systems including compressor, condenser coil, condenser fan and evaporator coil with expansion valve. The condenser coils shall have sub-cooling rows. The compressors shall be internally spring mounted and have positive crankshaft lubrication, crankcase heater, discharge temperature limiter, current and temperature sensing motor overloads.

Condenser Indoor Heat—The refrigeration system shall have an indoor condenser coil which delivers 125,000 or 155,000 Btuh of heat to the conditioned area whenever the system requires simultaneous heating and cooling. It shall be located in the hot deck.

Chilled Water System—The total certified cooling capacity shall not be less than Btuh with a cooling coil air volume of cfm, an entering wet bulb air temperature of F with a flow rate of gpm and an entering water temperature of F.

The water coil shall be non-ferrous construction with aluminum fins bonded to seamless copper tubes. It shall be factory pressure leak tested at 450-500 psi. A modulating motorized water valve shall be factory installed.

Gas Heating System—The certified total heating capacity output shall be Btuh with a gas input of Btuh. Automatic controls furnished as standard equipment shall give two stage operation, except on propane fired single heat exchanger models single stage operation only is available. Cylindrical tube and drum heat exchanger shall be constructed of (aluminized steel or glass coated steel). Stainless steel power burner(s) shall have pre-purge, intermittent spark ignition (continuous pilot flame during main burner operation), 100% safety shutoff controls, electronic flame sensing controls, series gas valves and fan controls to terminate blower operation at night. Staging control shall be with separate gas valves. An automatic safety shutoff valve shall be furnished.

Electric Heating System—The certified total heating capacity output shall be Btuh at volts power supply.

Heating elements shall be nichrome bare wire exposed directly to the air stream and be equipped with manual reset backup limits. They shall be controlled by a (four stage controller or sequencer) with 1st stage controlling condenser heat.

Hot Water Heating System—The certified total heating capacity output shall be Btuh with a heating coil air volume of cfm, at water entering air temperature of F and a flow rate of gpm and an entering air temperature of F. A three way modulating water valve (with/without) primary pump shall be factory installed. The coil shall be of non-ferrous construction with aluminum fins mechanically bonded to seamless copper tubes.

Steam Heating System—The certified total heating capacity output shall be Btuh, with an air volume of cfm at an entering air temperature of F and lbs. steam pressure.

A modulating steam valve and float shall be factory installed. The coil shall be of non-ferrous construction with aluminum fins mechanically bonded to seamless copper tubes. Coil shall be self draining and distributed to provide even temperature across the unit.

Frame and Casing—All external surfaces shall be of painted (outdoor enamel) 20 gauge galvanized steel 0.0396" thick or (base frame) 6061-T6 extruded aluminum. All galvanized side and top panels shall be insulated with 1-1/2" thick fiberglass insulation. The extruded aluminum base shall be lined with 1" thick fiberglass insulation. The top panels shall be joined with a 3/16" diameter rubber tubing in the bottom of each standing seam. Side panel seams shall be sealed with polyurethane foam. All interior support members shall be 16 ga. steel. All access panels shall have locking door handles.

Supply Air Blowers—Twin supply air blowers shall have permanently lubricated ball bearings, velocity pressure converters, adjustable belt drives and a cradle motor mount where belt tension can be easily adjusted. The entire assembly shall be floated on steel springs. They shall be capable of delivering cfm at an external static pressure of inches water gauge requiring bhp and rpm.

Return Air Blower—Shall have permanently lubricated ball bearings, adjustable belt drives and be capable of exhausting cfm at an external static pressure of inches water gauge requiring bhp and rpm.

Frame Filters—Filter media shall be 1 inch 20 pores per inch polyurethane enclosed in individual galvanized frames. Total free area shall be 33.5 sq. ft. Filter rack shall be wide enough to allow addition of up to 3" of other filtering material.

Bag Filter—Shall be equipped with a frame pre-filter and have an efficiency of % based on National Bureau of Standards dustspot test.

Automatic Roll Filters—65 ft. roll of 2 inch fiberglass shall have an automatic (timed or pressure drop) advance.

Service Enclosure—Shall be available to protect service area from inclement weather during service period.

Approvals—All gas models shall be A.G.A. certified or C.G.A. Approved. Hot water, electric heat models and cooling models shall be U.L. Listed. All electrical components shall have a U.L. Listing. All wiring shall be in compliance with NEC or CEC. F.I.A. and F.M. construction shall be available.

(Continued on next Page)

GUIDE SPECIFICATIONS (Cont'd)

(Continued)

Controls—All controls shall be the sole responsibility of the mechanical equipment manufacturer and shall be installed factory wired and tested.

Smoke Detector Controls—Shall be available to detect the presence of smoke within the system and actuate the blower motor controls and other devices to prevent the spread of smoke throughout the conditioned area.

Alternate Electronic Energy Saving Control System—Shall consist of a room temperature sensing transmitter (set-point adjustable 55°F to 85°F) for each zone, a supply air sensor for each zone, zone damper actuators for each zone and a load analyzer control module with circuit board and heat-cool logic relays to operate the mechanical equipment. Mixed air low limit control, morning warm-up control and enthalpy control shall regulate a modulating damper actuator to provide outdoor air, return air and mixed air volume requirements. The room transmitter and supply air sensor shall have thermistors (semi-conductors with an electrical resistance that varies with temperature). The load analyzer control module shall provide a 24 volt DC regulated power supply to the room transmitter and heat-cool logic relays. The room transmitter shall convert the room temperature variations from set-point into a proportionally varying DC voltage. The supply air sensor, located in the supply air duct, shall sense the supplied air temperature and provide a signal which combines with the room transmitter signal to give the resultant output load signal. (The voltage signal produced by a 1 degree change at the room transmitter shall equal the signal produced by a 20 degree change at the supply air sensor.) As a result of the supply sensor signal the control system shall respond not only to the room temperature deviations from set-point but also to the effect of the outdoor air and the mechanical systems response to the load. The load analyzer control module shall operate the mechanical equipment, through the heat-cool logic relays, according to the amount of the voltage (signal) received. The logic relays are sensitive to varying voltages and in conjunction with the modulating voltage signals for the zone damper actuators and mixed air/ventilation damper actuator shall be programmed to operate the mechanical equipment automatically in sequence, as required, through the cooling, ventilating and heating cycles. The load analyzer control module shall also provide a central location for troubleshooting and identification of improper wiring.

Alternate Load Sensor Master/Sub-Master Control System—

Fresh Air Control—Shall include a step controller and outside reset Master/Sub-Master cold deck ductstat. They shall control a modulating damper motor to deliver the required amount of outdoor air into the conditioned area. An adjustable enthalpy control shall prevent excessive moisture laden outside air from entering by returning the damper motor to the minimum position.

Cold Deck Control—The cold deck temperature shall be controlled by an adjustable outside reset ductstat and a modulated step controller.

Chilled Water Cold Deck Controls—Shall include dual outside reset ductstats and a modulating motorized valve to maintain a cold deck air temperature appropriate to the outdoor air temperature.

The control system shall be Master/Sub-Master controlled to automatically shift the cold deck temperature down as much as 10F colder during periods of peak loading.

Gas Fired Hot Deck Control—The hot deck temperature shall be controlled by an adjustable outside reset ductstat and a four stage controller to maintain a hot deck air temperature appropriate to the outdoor air temperature.

Electric Heat Hot Deck Controls—Shall include an outside reset ductstat and a (four stage or sequencer) which maintains a hot deck air temperature appropriate to the outdoor air temperature.

Hot Water and Steam Heat Hot Deck Controls—Shall include an outside reset ductstat and a modulating motorized valve to maintain a hot deck air temperature appropriate to the outdoor air temperature.

The control system shall be Master/Sub-Master controlled to automatically shift the hot deck temperature up as much as 20F during periods of peak loading.

Zone Controls—Shall be modulating zone damper motor which is controlled by a wall mounted thermostat.

Outside Air Damper—Damper blades shall ride in nylon bearings. Damper motor shall be full modulating with adjustable potentiometer for minimum position.

CHILLED WATER VALVE (Four Row Coil)

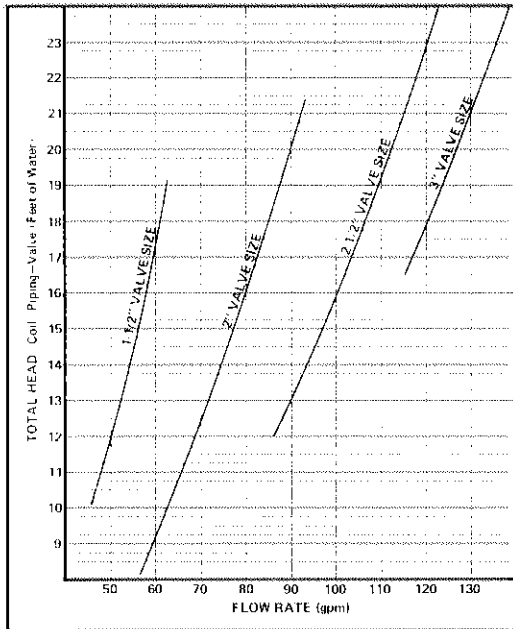

CHILLED WATER VALVE (Six Row Coil)

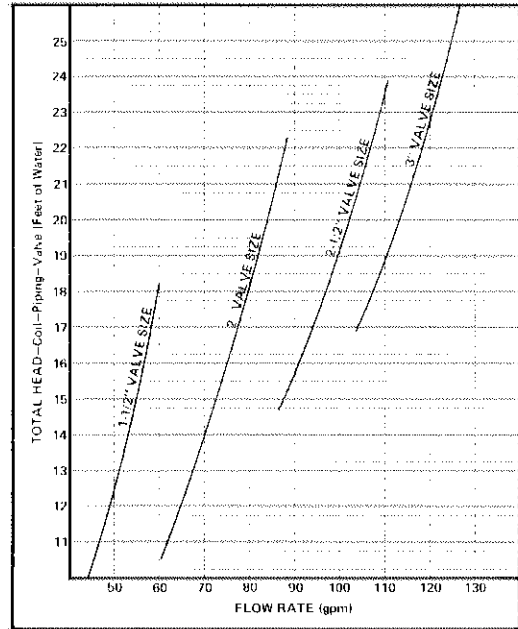

HOT WATER VALVE

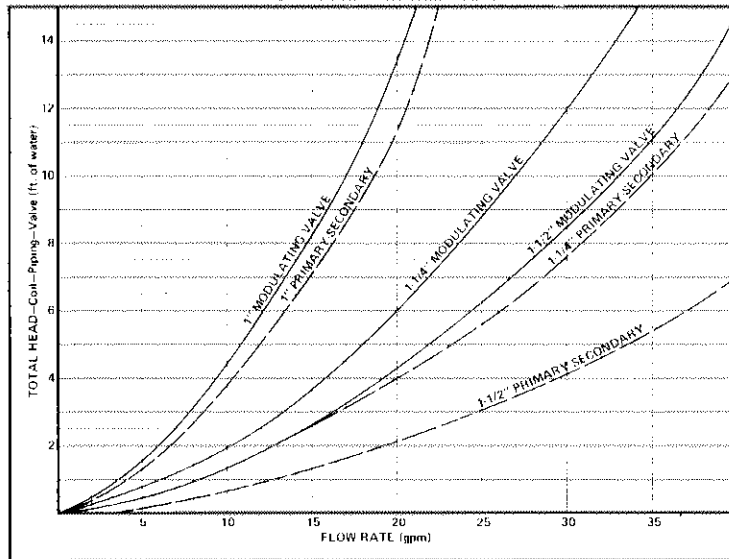

STEAM VALVE AND PRESSURE DROP

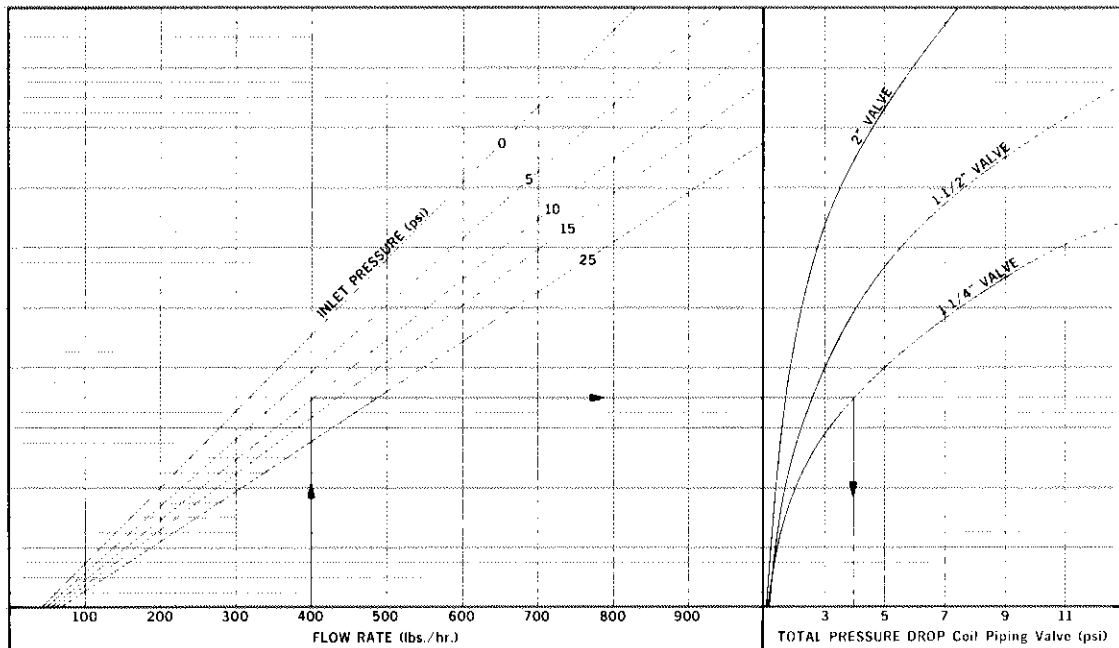

DMS3-415-600 HOT WATER HEATING CAPACITY VALVE CONTROL SYSTEM

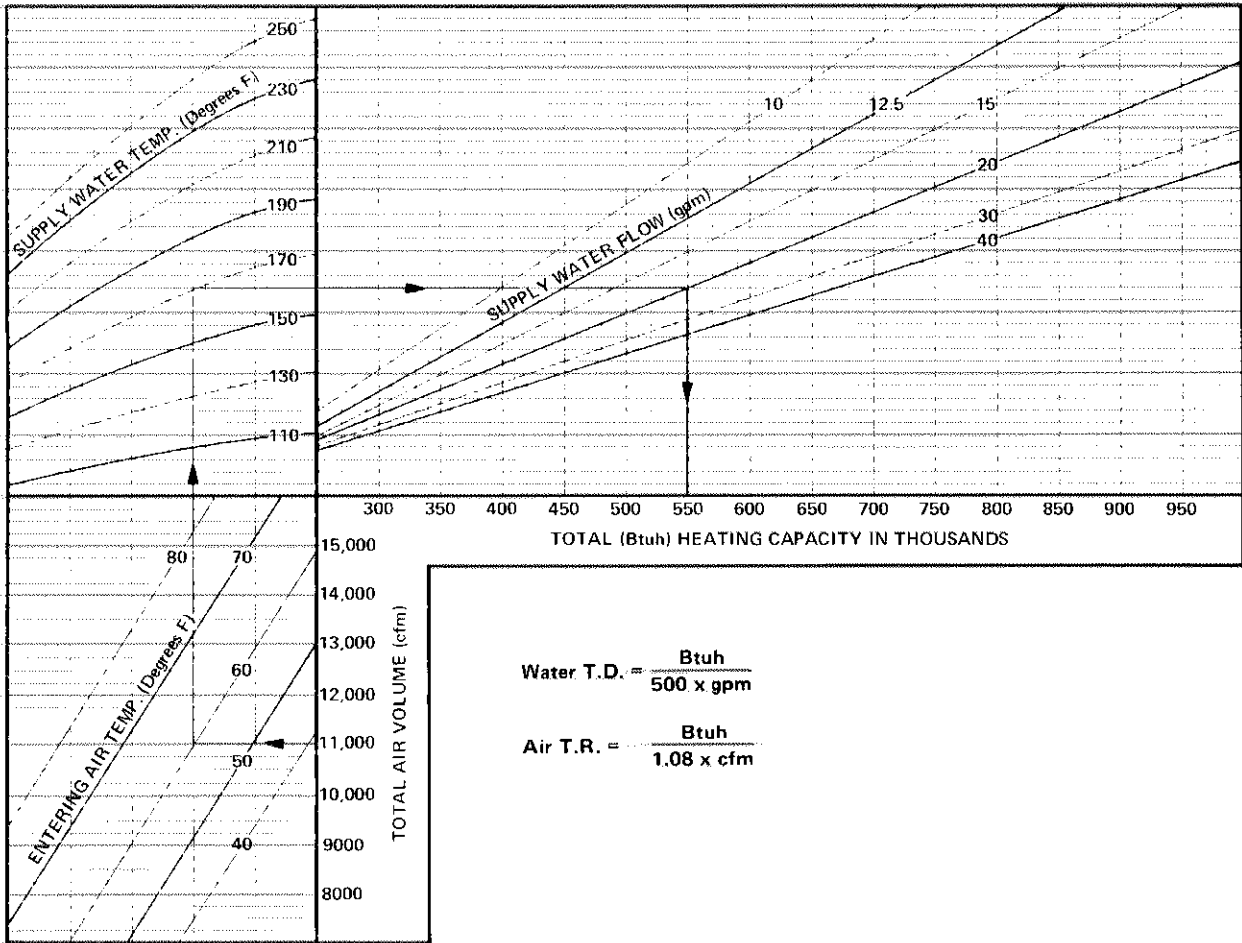

PRIMARY-SECONDARY SYSTEM

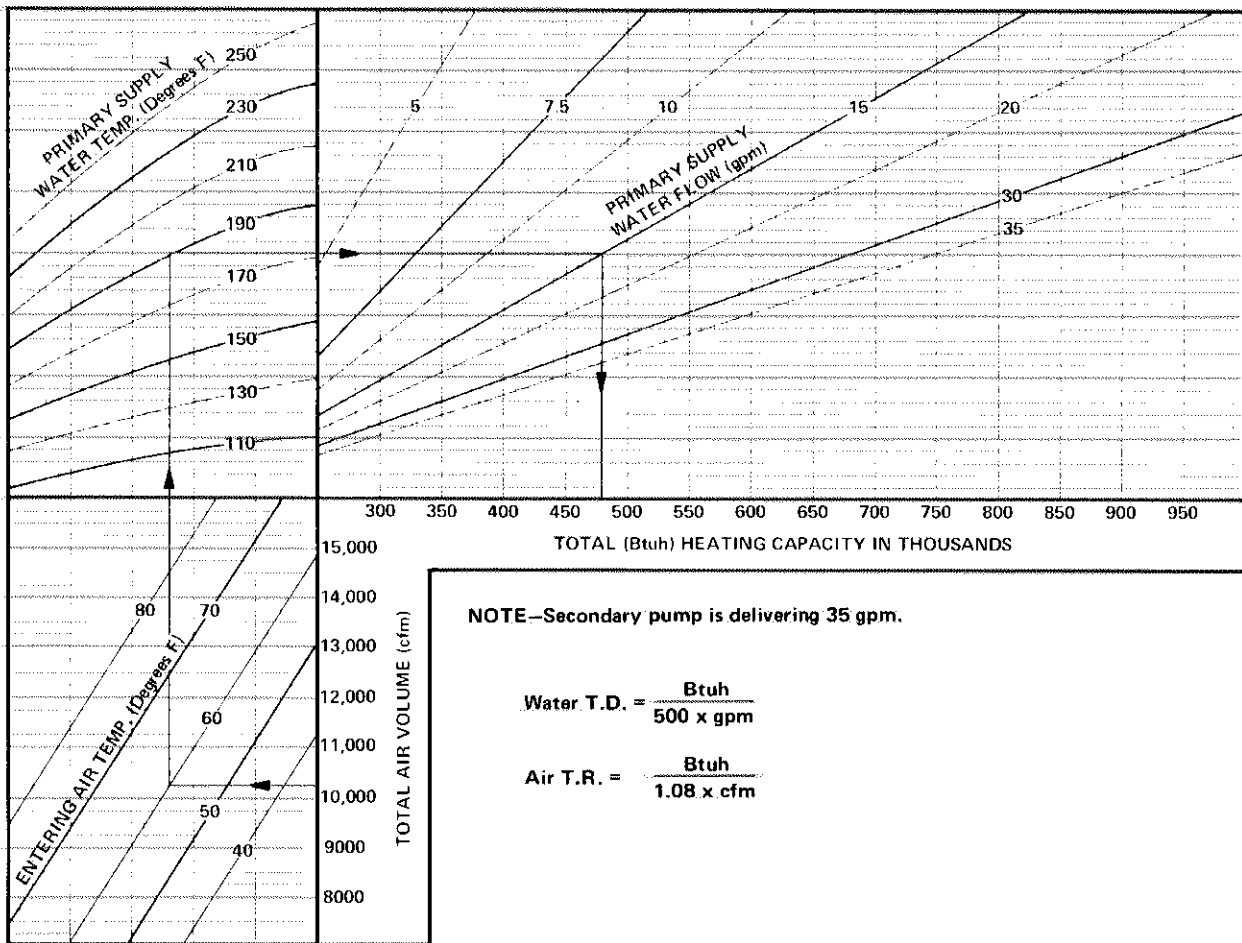

DMS3-415 CONDENSING SECTION CAPACITY CURVE

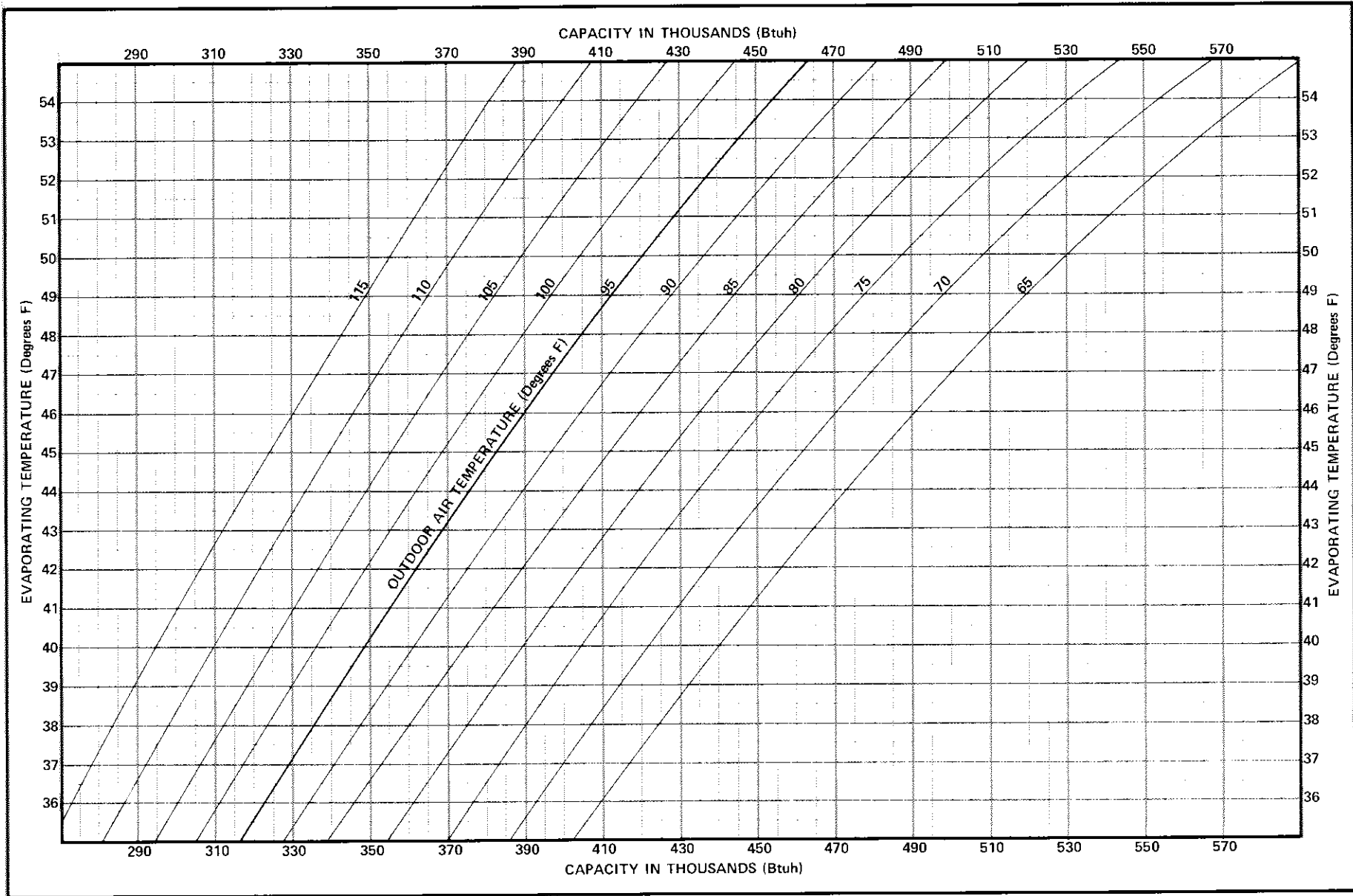

NOTE—Capacity shown is total capacity with all three condensing sections running.

DMS3-600 CONDENSING SECTION CAPACITY CURVE

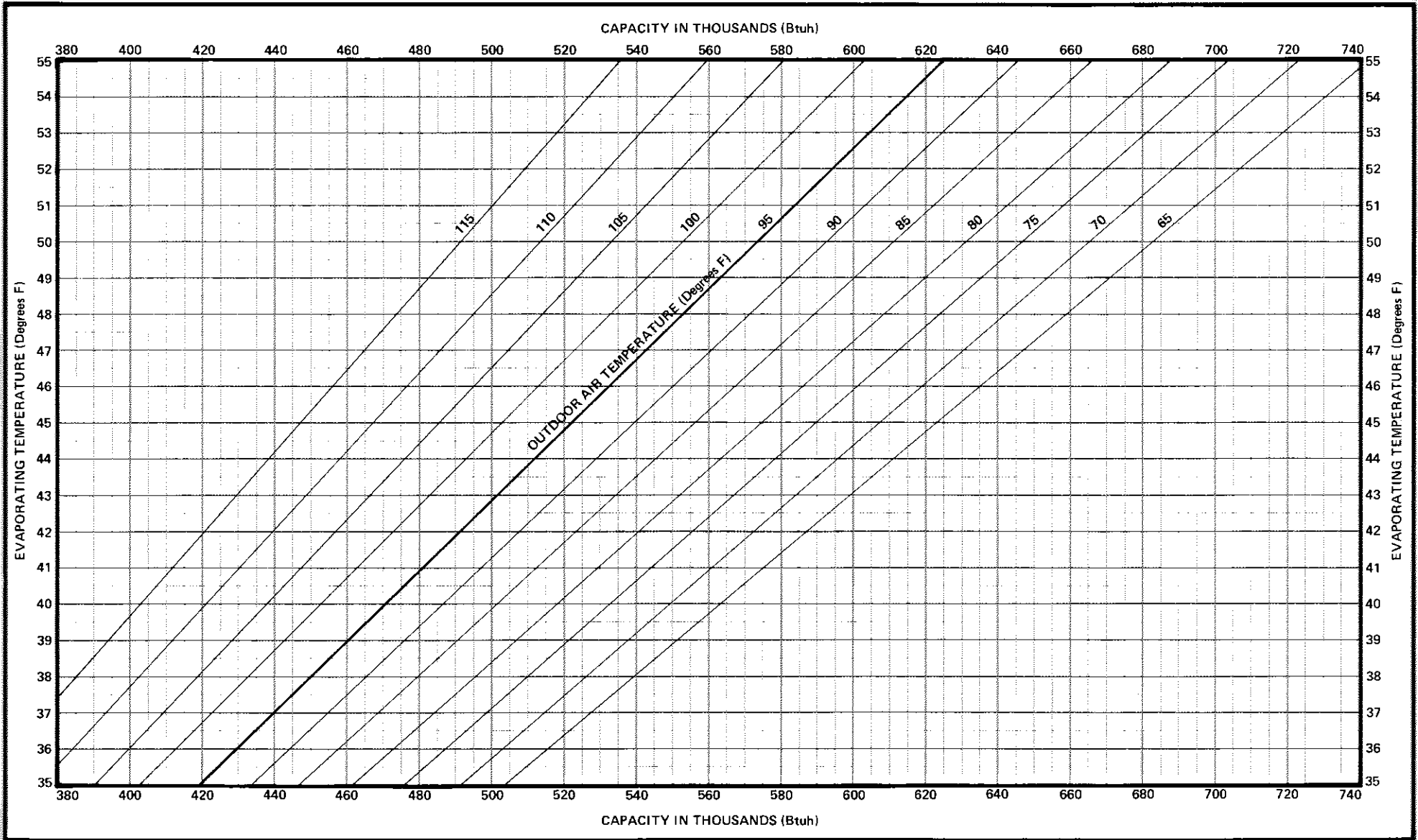

NOTE—Capacity shown is total capacity with all three cooling sections running.

DMS3-415-600 EVAPORATOR COIL PERFORMANCE CURVE

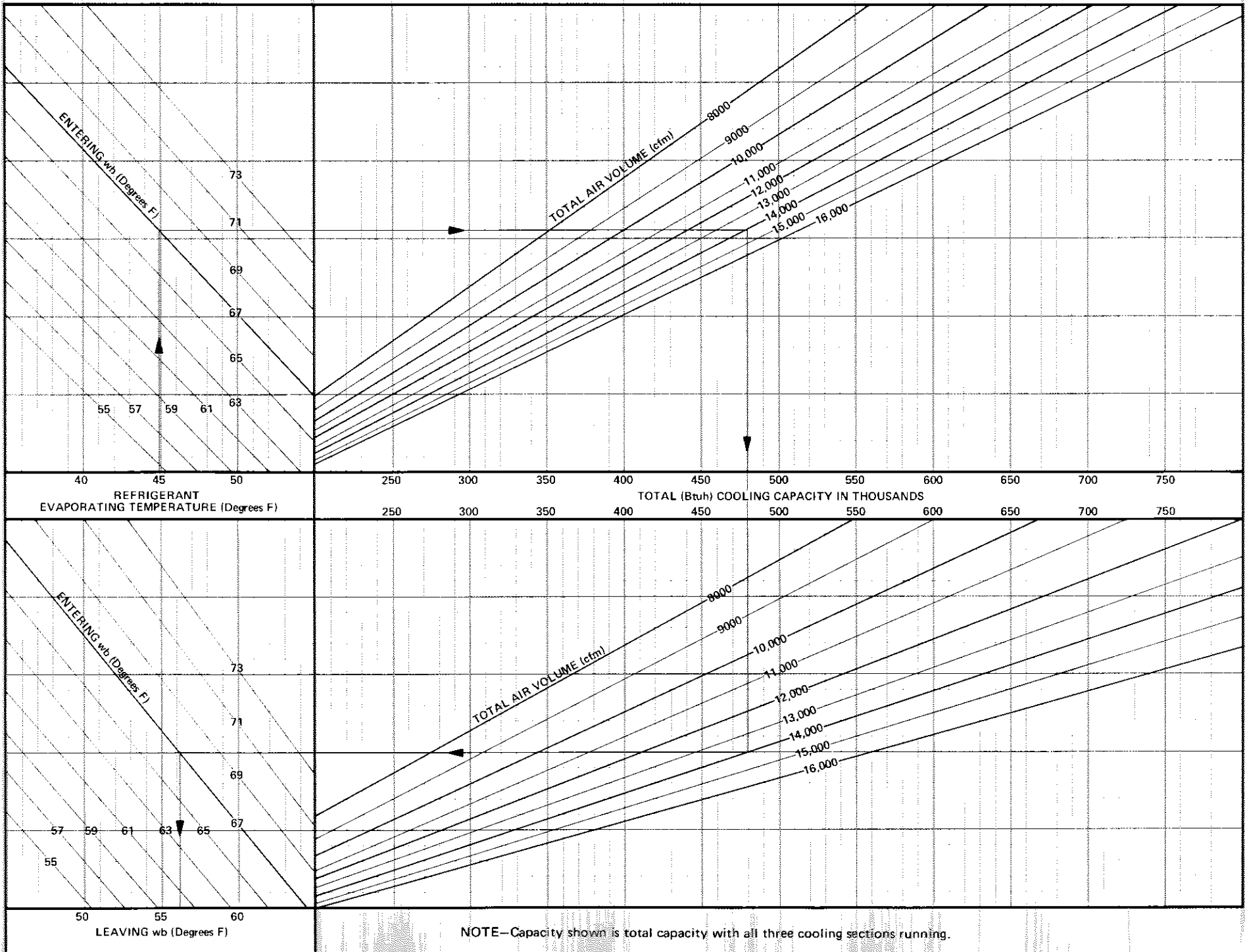

NOTE—Capacity shown is total capacity with all three cooling sections running.

DMS3-415-600 EVAPORATOR COIL LEAVING DRY BULB TEMPERATURE CURVE

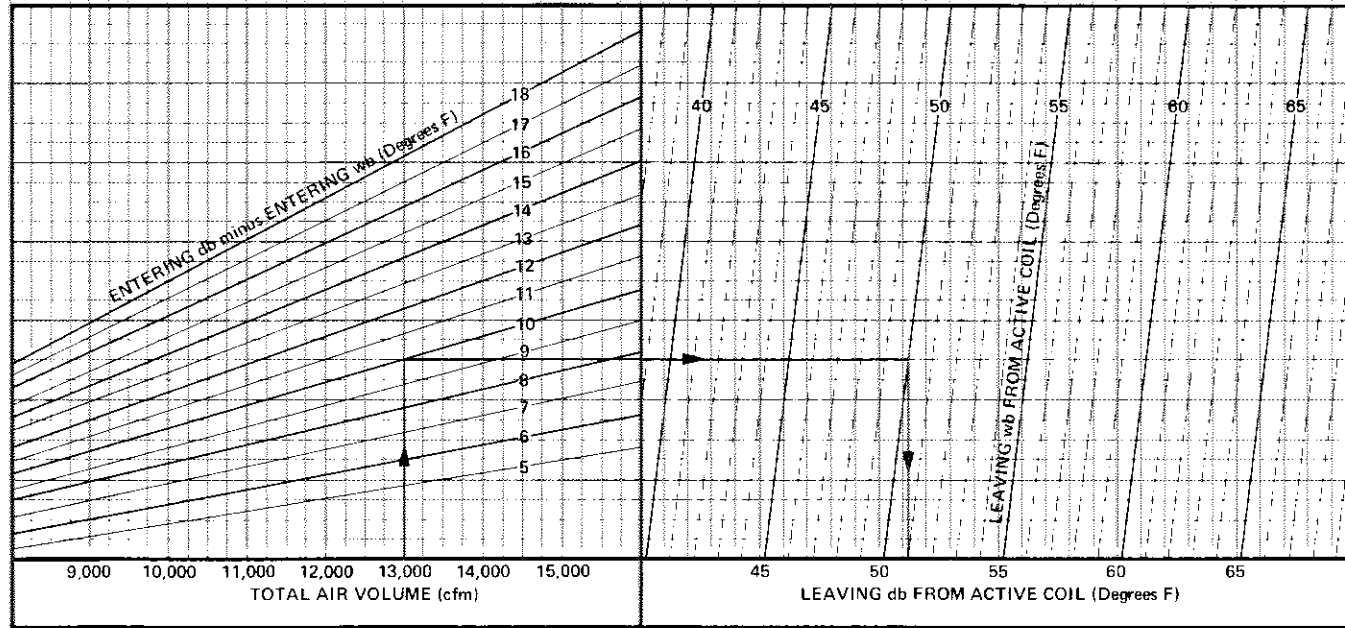

DMS3-415-600 EVAPORATOR COIL SENSIBLE COOLING CAPACITY CURVE

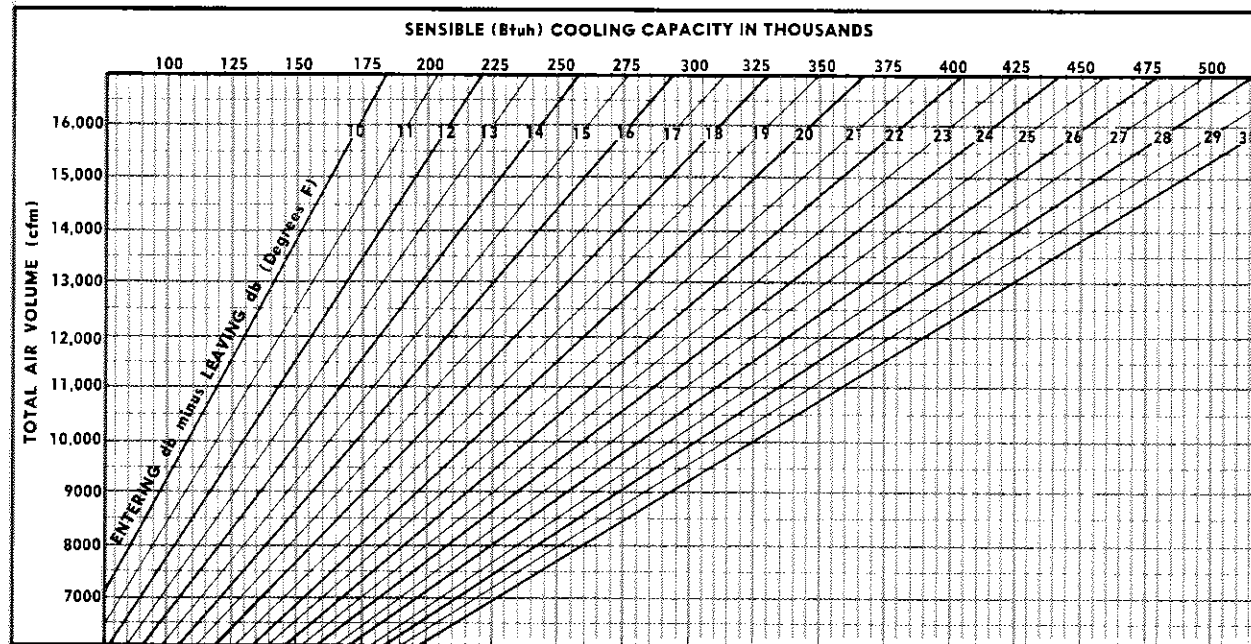

NOTE—In rare applications the combination of a very high refrigerant evaporating temperature, low entering wet bulb temperature and an unusually high air volume will result in reading from the charts a greater sensible cooling capacity than the total cooling capacity. Therefore in these applications the sensible cooling capacity is the same as the total cooling capacity.

DMS3-415-600 FOUR ROW CHILLED WATER COIL PERFORMANCE CURVE

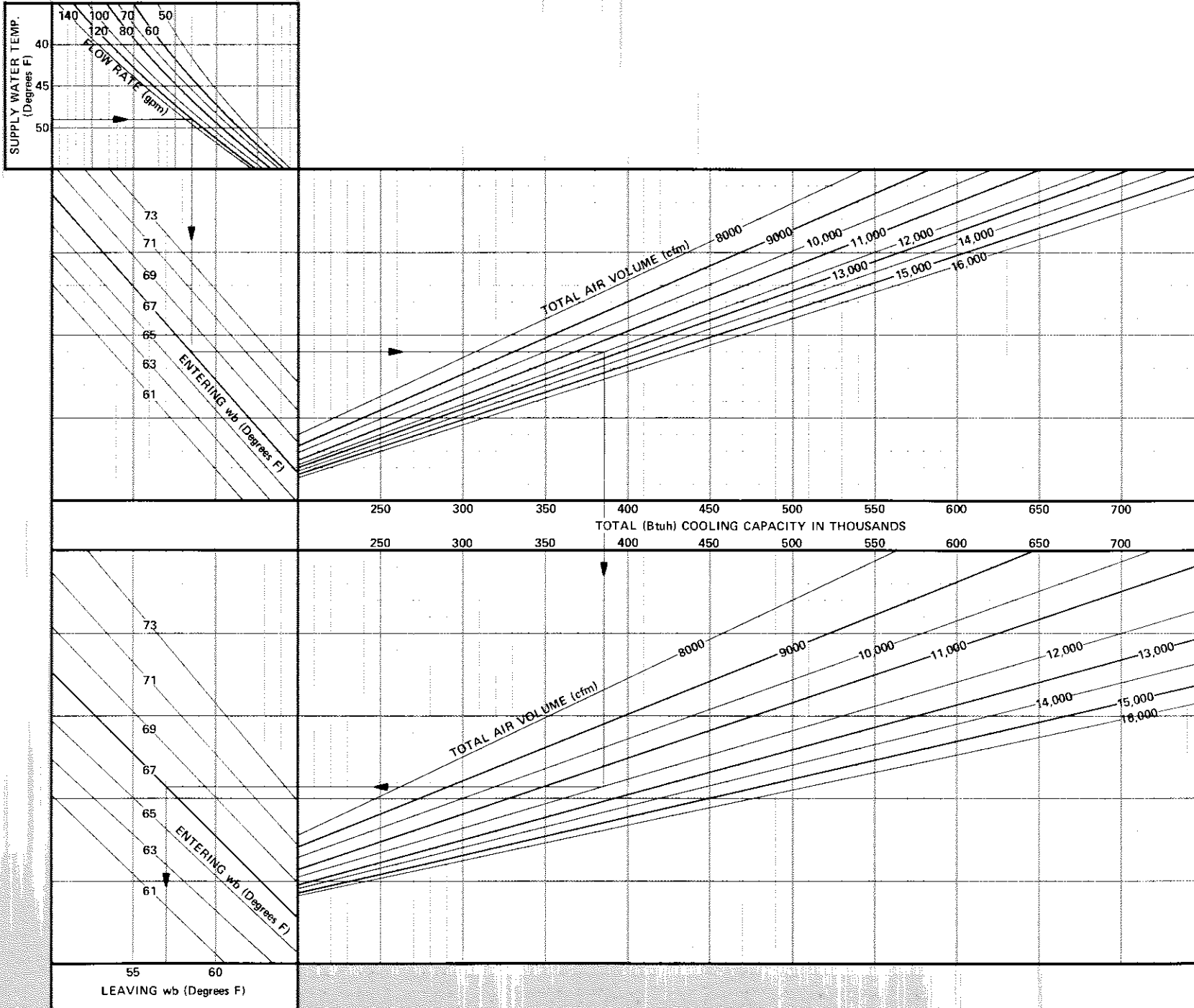

DMS3-415-600 FOUR ROW CHILLED WATER COIL LEAVING DRY BULB TEMPERATURE CURVE

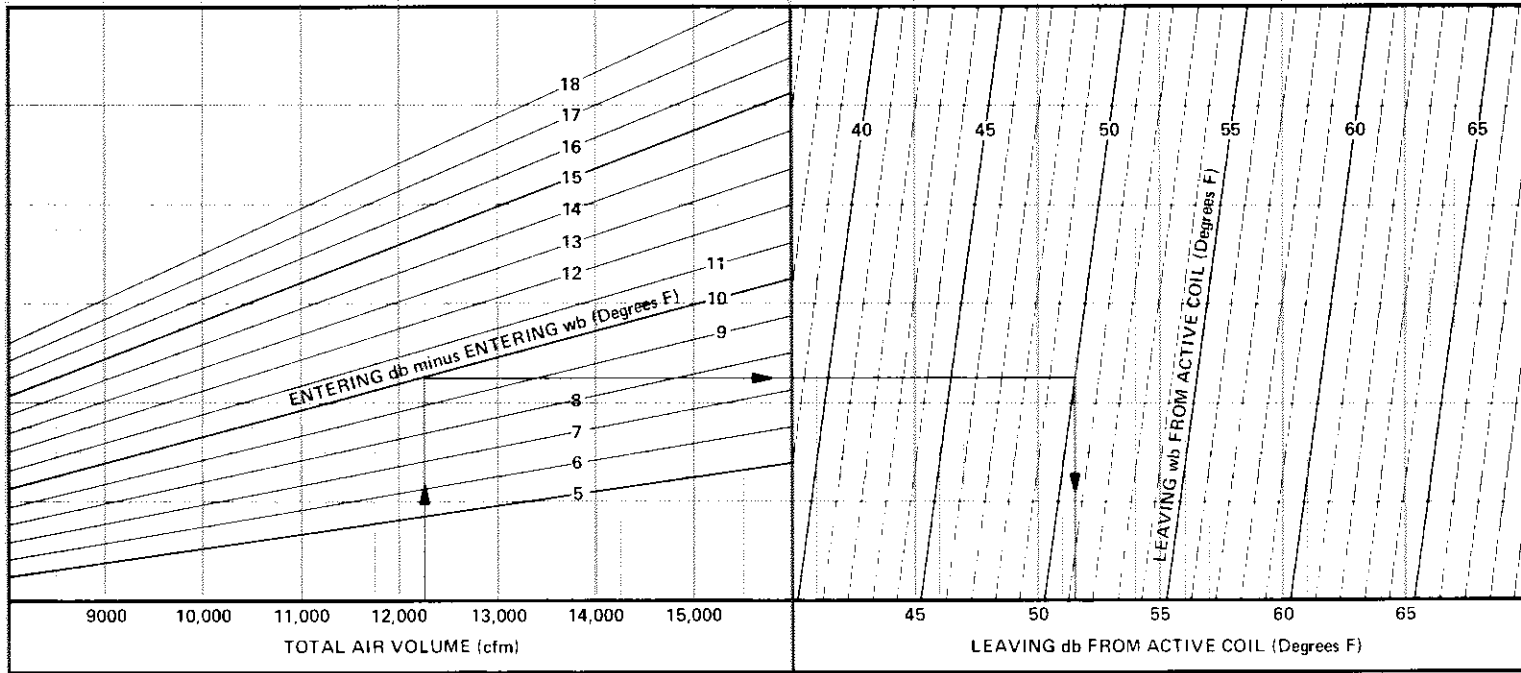

DMS3-415-600 FOUR ROW CHILLED WATER COIL SENSIBLE COOLING CAPACITY CURVE

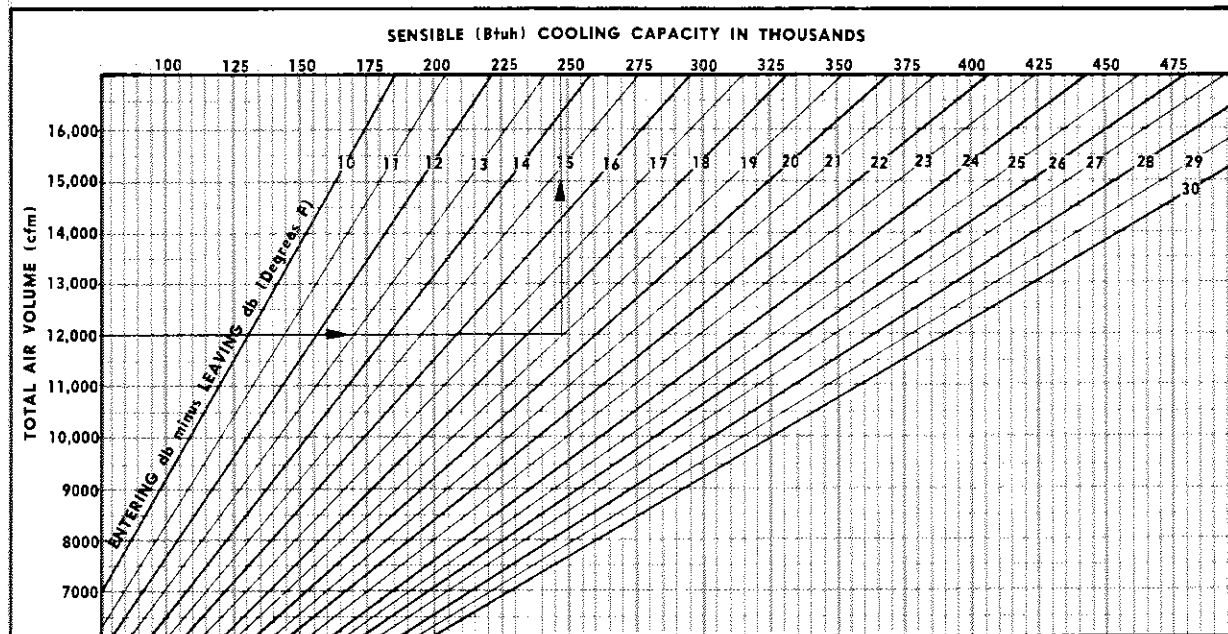

NOTE—In rare applications the combination of a very high entering water temperature, low entering wet bulb temperature and an unusually high air volume will result in reading from the charts a greater sensible cooling capacity than the total cooling capacity. Therefore in these applications the sensible cooling capacity is the same as the total cooling capacity.

DMS3-415-600 SIX ROW CHILLED WATER COIL PERFORMANCE CURVE

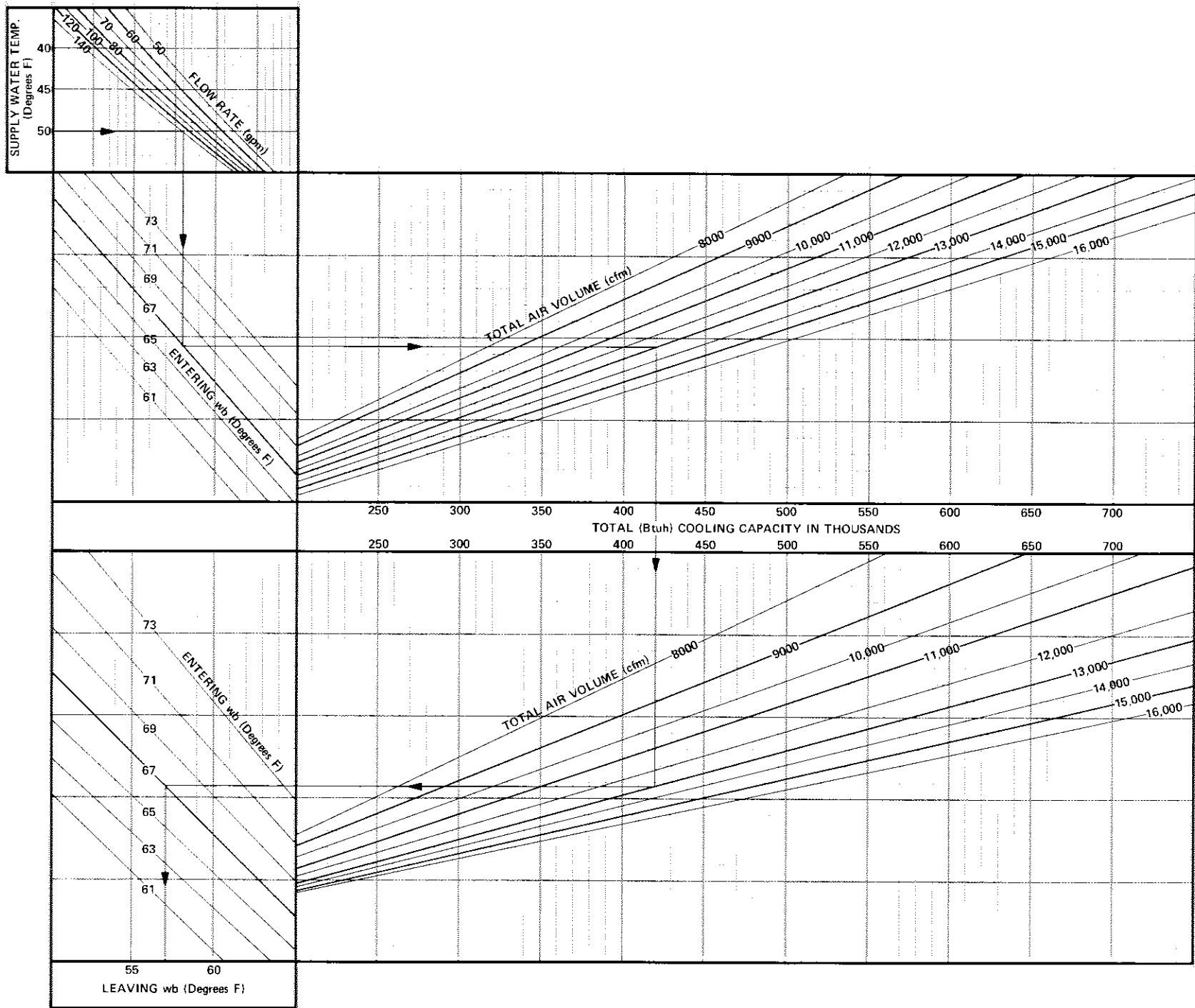

DMS3-415-600 SIX ROW CHILLED WATER COIL LEAVING DRY BULB TEMPERATURE CURVE

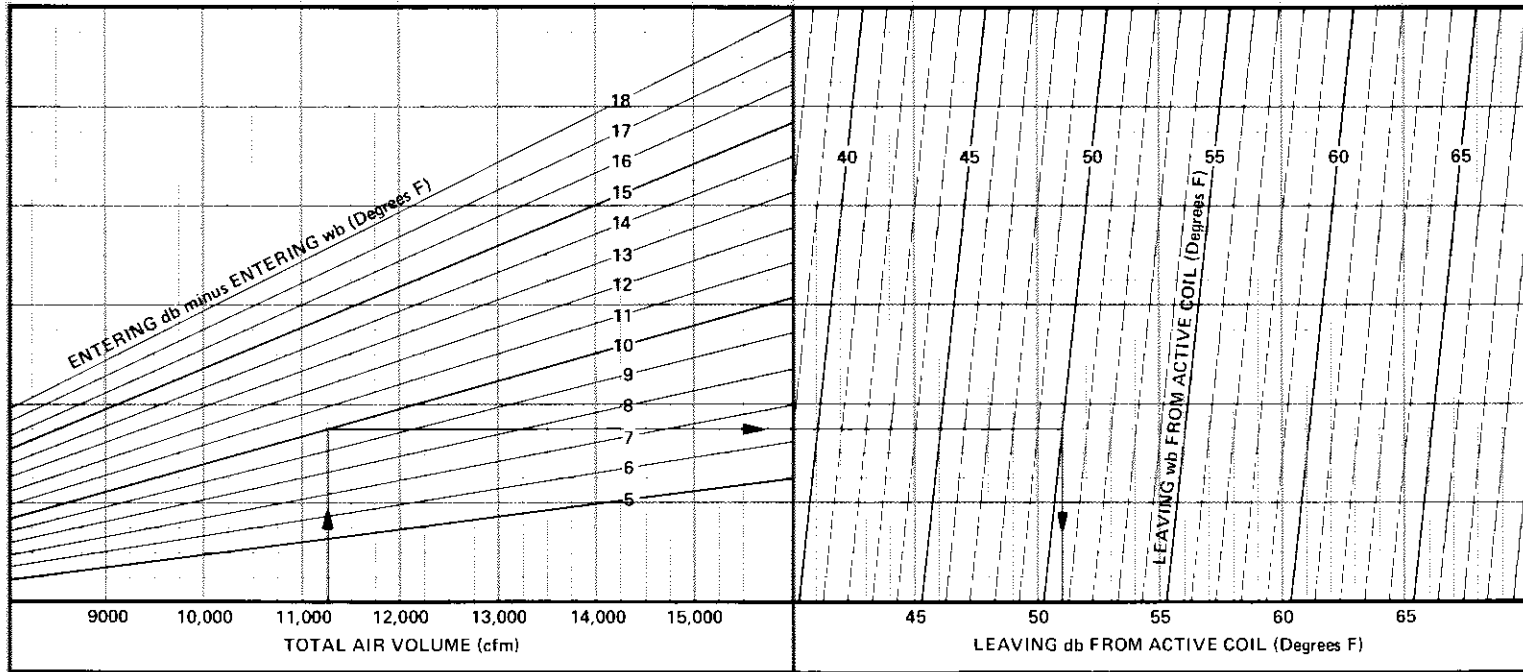

DMS3-415-600 SIX ROW CHILLED WATER COIL SENSIBLE COOLING CAPACITY CURVE

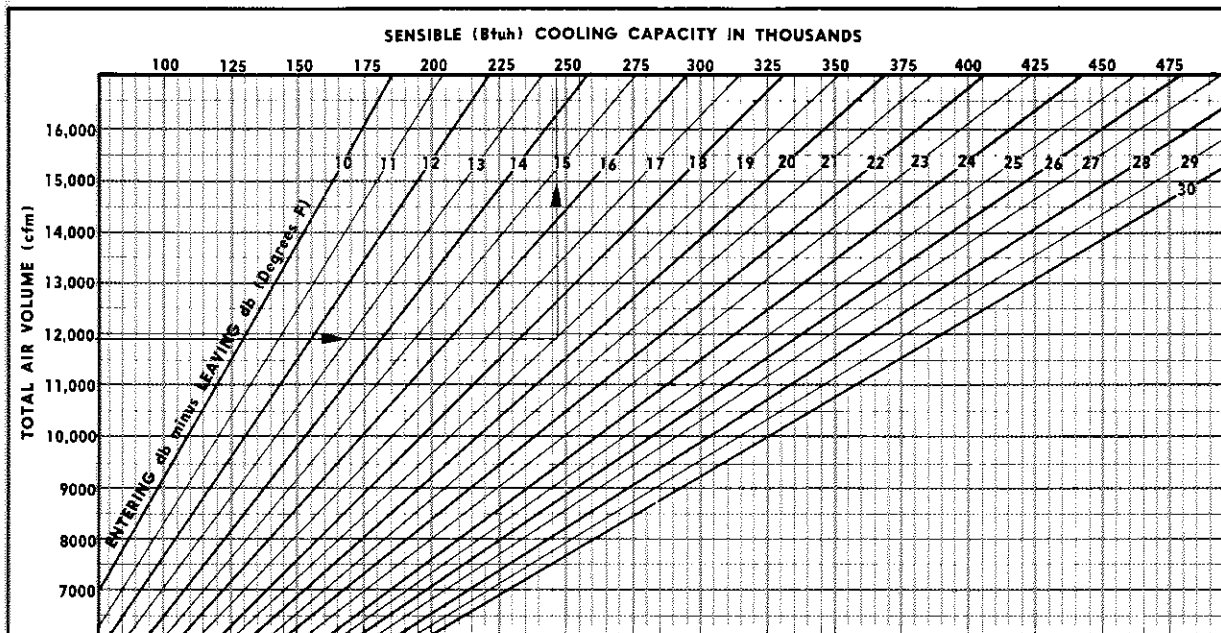

NOTE—In rare applications the combination of a very high entering water temperature, low entering wet bulb temperature and an unusually high air volume will result in reading from the charts a greater sensible cooling capacity than the total cooling capacity. Therefore in these applications the sensible cooling capacity is the same as the total cooling capacity.