

# LENNOX®

## ENGINEERING DATA

## GAS FURNACES

# G21Q

Bulletin #480175  
September 1992  
Supersedes  
March 1992

## G21Q "PULSE21®" SERIES UP-FLO GAS FURNACES

\*93.2% to 96.2% A.F.U.E.

40,000 to 100,000 Btuh Input

Add-On Cooling — 1-1/2 thru 5 Nominal Tons

\*Isolated Combustion System Rating for Non-Weatherized Furnaces



### Typical Applications

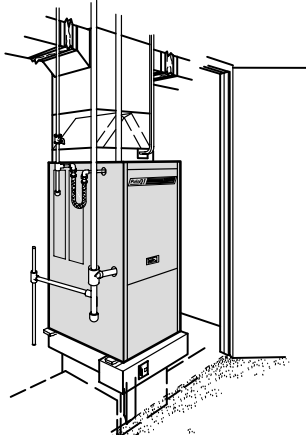

Closet Installation  
With cooling coil and  
electronic air cleaner

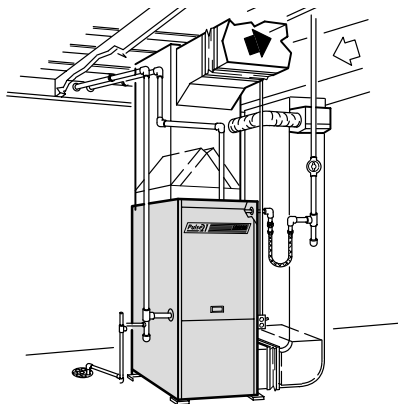

Utility Room Installation  
With cooling coil, return air  
cabinet and humidifier

**POSITION  
ONLY 5A**

**Application** — Lennox G21 series gas furnaces are available in eight models (natural gas or LPG) with input capacities of 40,000, 60,000, 80,000 and 100,000 Btuh. Units operate on the pulse combustion principle and do not require conventional pilot burner, main burners, flue or chimney. Standard size cabinet with side or bottom return air entry permits installation in a basement, utility room or closet. Lennox add-on evaporator coils, electronic air cleaners and power humidifiers can easily be added for a total comfort all-season system. Replacement of furnaces manufactured by Lennox in the last twenty-five years can be done with only minor modification to duct work or add-on coils.

High efficiency of the G21 series is achieved with a unique heat exchanger design which features: finned cast iron combustion chamber, temperature resistant steel tailpipe, aluminized steel exhaust decoupler section and a finned stainless steel tube condenser coil. Moisture, during the process of combustion, is condensed in the coil, extracting almost every usable Btu out of the gas. Most of the combustion heat is utilized in the heat transfer from the coil, producing flue vent temperatures as low as 100F to 130F which allows the use of PVC (polyvinyl chloride) pipe for venting. Furnace can be vented through a side wall, roof or to the top of an existing chimney with up to 35 ft. of PVC pipe and up to four 90 degree elbows. Condensate created in the coil (PH ranges from 4.0 to 6.0) is not harmful to standard household plumbing and can be drained into city sewers and septic tanks without damage.

The G21 furnace has no pilot light or burners. An automotive type spark plug is used for ignition on the initial cycle only, saving gas and electrical energy. In the pulse combustion process, the use of atmospheric burners is eliminated, with combustion confined to heat exchanger combustion chamber. Sealed combustion system virtually eliminates the loss of conditioned air due to combustion and stack dilution. Combustion air is piped to the furnace with same type PVC pipe as used for exhaust gases.

Furnace is equipped with standard type redundant gas valve in series with gas expansion tank and gas intake flapper valve. Also factory installed are an air intake flapper valve, purge blower, spark plug igniter, flame sensor with solid-state control, solid-state blower control, limit control, high and low voltage terminal strip, 30VA transformer and cleanable air filter. Furnished for field installation are a flexible gas line connector, (4) isolation mounting pads, base insulation pad and condensate drip leg.

Optional equipment available: flue vent/air intake line roof or wall termination installation kits, LPG conversion kits, mufflers, furnace twinning kit, continous low speed blower kit, external filter mounting kit and thermostat.

G21 units are shipped completely factory assembled with all controls installed and wired. Units are test fired at the factory before shipment.

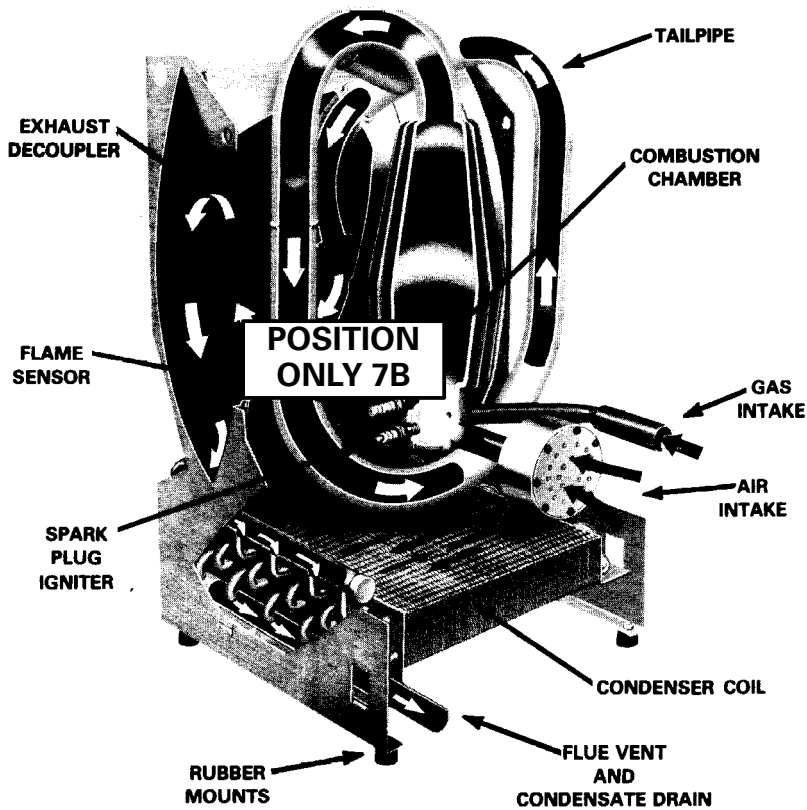

## PROCESS OF COMBUSTION

The process of combustion begins as gas and air are introduced into the sealed combustion chamber with the spark plug igniter. Spark from the plug ignites the gas/air mixture, which in turn causes a positive pressure build-up that closes the gas and air inlets. This pressure relieves itself by forcing the products of combustion out of the combustion chamber through the tailpipe into the heat exchanger exhaust decoupler and on into the heat exchanger coil. As the combustion chamber empties, its pressure becomes negative, drawing in air and gas for the next pulse of combustion. At the same instant, part of the pressure pulse is reflected back from the tailpipe at the top of the combustion chamber. The flame remnants of the previous pulse of combustion ignites the new gas/air mixture in the chamber, continuing the cycle. Once combustion is started, it feeds upon itself allowing the purge blower and spark plug igniter to be turned off. Each pulse of gas/air mixture is ignited at a rate of 60 to 70 times per second, producing from one-fourth to one-half of a Btu per pulse of combustion. Almost complete combustion occurs with each pulse. The force of these series of ignitions creates great turbulence which forces the products of combustion through the entire heat exchanger assembly resulting in maximum heat transfer.

## FEATURES

**Approvals** — G21 series furnaces are designed certified by A.G.A. Laboratories and ratings are certified by GAMA. Units meet the California Nitrogen Oxides (NO<sub>x</sub>) standards and California Seasonal Efficiency requirements. In addition, units have been rated and tested in the Lennox Research Laboratory according to Department of Energy (DOE) test procedures and Federal Trade Commission (FTC) labeling regulations. Blower data is from unit tests conducted in the Lennox Laboratory air test chamber.

**Equipment Warranty** — G21 "Pulse" heat exchangers have a limited lifetime warranty. Solid-state ignition modules have a limited warranty for three years. All other components have a limited warranty for one year. Refer to Lennox Limited Equipment Warranty certificate included with the equipment for details.

**Sequence of Operation** — Room thermostat, on a demand for heat, will initiate purge blower operation for a pre-purge cycle (30 seconds) followed by energizing and opening of the gas valve. As ignition occurs, the flame sensor reacts to proof of ignition and de-energizes the spark plug igniter and purge blower after 8 seconds. Furnace blower operation is initiated 30 to 60 seconds (adjustable) after combustion ignition. When thermostat is satisfied, gas valve is closed and purge blower is re-energized for a post-purge cycle (34 seconds). Furnace blower will remain in operation until "fan off" factory setting of 180 seconds (adjustable from 120 to 240 seconds) is reached. Should loss of flame occur before thermostat is satisfied, flame sensor controls will initiate 5 attempts at re-ignition before locking out unit operation. Additionally, loss of either combustion intake air or flue exhaust will automatically terminate system operation. If unit becomes locked out, Watchguard circuit on GC3 ignition control automatically resets ignition controls after one hour of continuous thermostat demand.

**Heat Exchanger Assembly** — Lennox developed heat exchanger assembly consists of combustion chamber, tailpipe, exhaust decoupler section and condenser coil. Combustion chamber contains the spark plug igniter, flame sensor and combustion air and gas intake manifolds. Cast iron construction provides excellent radiation of heat over entire surface area. Finned "teardrop" shape design permits total air coverage of all surfaces with low resistance. Tailpipe connects

the combustion chamber to the exhaust decoupler section. Precisely sized and shaped tailpipe is constructed of combination stainless and aluminized steel for superior resistance to high temperatures. Aluminized steel resonator on tailpipe minimizes combustion sound. Heavy gauge aluminized steel exhaust decoupler section has large surface area for maximum heat transfer. Air foil shape design results in complete air coverage with minimum air resistance. Condenser coil intake header connects to bottom of exhaust decoupler section. Large face area and circuiting of coil provides high heat transfer, minimum air resistance and proper moisture drainage. Coil is constructed of exactly spaced ripple-edged aluminum fins fitted to stainless steel tubes. Flared collars on fins grip tubes for maximum contact area. Flared tubing connections and high temperature brazing provide tight, leakproof joints. Combined flue vent and condensate drain outlet is located on the coil. Coil is factory tested for leaks. All components are mounted in a heavy gauge steel frame and installed in the furnace cabinet on resilient rubber mounts assuring quiet, vibration free operation. Heat exchanger has been laboratory life cycle tested.

**Rugged Cabinet** — Constructed of heavy gauge cold rolled steel. Cabinet is subject to a five station metal wash process resulting in a perfect bonding surface for a paint finish of baked-on enamel. The paint solution and metal are given opposite electrical charges resulting in positive adhesion and even coverage of the paint to the metal surfaces. Heat exchanger section is completely lined with thick (1-1/2 lb./ft.<sup>3</sup> density) foil faced fiberglass insulation. Blower compartment is completely lined with thick (1-1/2 lb./ft.<sup>3</sup> density) black mat faced fiberglass insulation. This results in quiet and efficient operation due to the excellent acoustical and insulating properties of fiberglass. Complete service access is accomplished by removing heating section and blower access panels. Removable panel is provided in vestibule panel for access to the spark plug and flame sensor. Holes are located in the base for cabinet leveling. Leveling bolts and nuts are not provided and must be ordered extra. Safety interlock switch automatically shuts power off to unit when blower access panel is removed. Blower assembly may be completely removed from unit for servicing. Electrical inlets, gas line inlets and exhaust air outlets are provided in both sides of cabinet. Combustion air inlet opening is located in cabinet cap. Return air duct connection can be made on either side or bottom of cabinet.

## FEATURES

**Powerful Blowers** — Units are equipped with quiet multi-speed direct drive blowers. Each blower assembly is statically and dynamically balanced. Multiple-speed leadless motor is resiliently mounted. A choice of blower speeds is available on each blower. See blower performance tables. Change in blower speed is easily accomplished by simple wiring change.

**Solid-State Blower Control** — Circuit board located in wiring junction box contains all necessary controls to automatically operate the blower. Contains adjustable blower timed-on control (30 to 60 seconds – factory setting 45 seconds) and adjustable blower timed-off control (120 to 240 seconds – factory setting 180 seconds).

**Cleanable Air Filters** — Washable or vacuum cleanable frame type filter is furnished as standard. Polyurethane media is coated with oil for maximum efficiency. Filter is readily accessible in unit for quick and easy removal for servicing.

**Combustion Air Intake Box** — Contains the purge blower, air intake flapper valve and air valve housing. The 40, 60 and 80 units have a single differential pressure switch mounted inside the unit cabinet. The 100 models have a single differential pressure switch mounted on the vestibule panel. Pressure switches terminate unit operation in case of air intake or flue exhaust blockage. Box is located on vestibule panel. Purge blower is equipped with a permanently lubricated motor. Blower operates only during pre-purge and post-purge cycles. Air is drawn through the blower during the combustion cycle by negative pressure in the combustion chamber. Flapper valve air housing is constructed of an elastomeric non-metallic polymer which reduces operating sound levels. Flapper valve section of the box is completely lined with 1 inch thick (6 lb./ft.<sup>3</sup> density) duct liner board, black neoprene coated fiberglass. Valve opening and closing is actuated by back pressure and negative pressure in combustion chamber during the heating cycle.

**GC3 Ignition Control** — Solid-state control provides power for spark plug igniter. Also controls pre-purge and post-purge cycles and re-ignition sequence if loss of flame occurs. Also features Watchguard circuit. Solid-state control provides automatic reset of ignition controls after 1 hour of continuous thermostat demand after unit lockout. Ignition control is factory installed on the vestibule panel.

## OPTIONAL ACCESSORIES (Must Be Ordered Extra)

**Thermostat (Optional)** — Heating thermostat is not furnished and must be ordered extra. See Thermostats bulletin in Accessories Section. For all-season applications, heating-cooling thermostat is available with the condensing unit.

**In-Line Mufflers (Optional)** — Two mufflers LB-52057CA (67F81) are optional and must be ordered extra. Mufflers field install, vertical or horizontal, one in the intake line and one in the exhaust line. See dimension drawings. Two mufflers are required on -80 & -100 units.

**Continuous Low Speed Blower Kit (Optional)** — Field installed kit LB-83611A (90H79) is available to provide continuous low speed blower operation. Kit includes switch and all necessary wiring. Kit is not furnished and must be ordered extra.

**Furnace Twinning Kit (Optional)** — Field Installed kit LB-63093A (64H88) is available to operate two furnaces simultaneously. Kit consists of heavy gauge steel control box and two auxiliary limit controls. Control box has electrical inlet knockouts and contains low voltage and high voltage terminal strips, blower control relay, heat relays, door interlock relay and 24 volt control transformer. All controls are factory installed and wired. Limit controls are field installed in each furnace. Holes for mounting control box are provided. Box may be field installed in any convenient location adjacent to or on one of the furnaces. Optional Continuous Low Speed Blower Switch (67H18) is available for plug-in connection to twinning kit.

**External Filter Mounting Kit (Optional)** — Kit is available for installing air filter external to unit cabinet on side return air applications. Heavy gauge cold rolled steel filter rack assembly field installs on either side of unit cabinet with existing screws. Rack has flanges for ease of duct connection. Filter is not furnished. Kit utilizes existing filter supplied with G21 unit. See Specifications tables.

**Limit Control** — Factory installed and accurately located on vestibule. Fixed limit control provides positive protection from abnormal operating conditions. Automatic reset.

**Automatic Gas Valve, Expansion Tank and Gas Intake Flapper Valve** — 24 volt redundant dual gas control valve combines gas pressure regulation and manual main shutoff valve into one compact combination control. Dual valve design provides double assurance of 100% close off of gas on each heating cycle. Expansion tank is located downstream from the gas valve and absorbs any pressure pulsations. Gas intake flapper valve is installed in the combustion chamber intake manifold between the orifice and expansion tank. Valve is opened by entering gas pressure and closed by back pressure from combustion pulse during the heating cycle.

**Wiring Junction Box** — Power supply and thermostat connections are made at the wiring junction box located on the vestibule panel. Box contains 30 VA transformer, high and low voltage terminal strips and blower cooling relay. Low voltage terminal strip has a fuse to protect the transformer. Terminal strip permits easy connections for optional power humidifiers and electronic air cleaners. Blower cooling relay activates blower operation for add-on air conditioning cooling.

**Installation Recommendations** — Lennox recommends the following installation procedures to minimize any vibration transmitted from furnace during operation. Place (4) neoprene rubber isolation mounting pads (furnished) and/or base insulation pad (furnished), 1 inch thick (1-1/2 lb./ft.<sup>3</sup> density) fiberglass, under the unit. Install flexible duct connectors in the supply air plenum and return air plenum or duct connection. Insulate (1 inch thick, 1-1/2 to 3 lb./ft.<sup>3</sup> density, mat faced fiberglass) supply and return air plenums through take-off or duct elbow. Use flexible gas connector (furnished) in gas supply piping where allowed by local codes. Insulate (refrigerant piping insulation or equivalent) all straps and hangers used in suspending ducts, electrical conduit, gas piping, combustion air intake piping and flue exhaust piping. In addition, use plastic pipe or tubing for drain line from the condensate coil drip leg (furnished) to the drain, do not use copper tubing.

**LPG Conversion Kits (Optional)** — For LPG models a conversion kit is available for field changeover from natural gas. Kit is not furnished and must be ordered extra. See Specifications tables.

**Concentric Vent/Intake Air Roof/Wall Termination Kit (Optional)** — Facilitates installation of combustion air intake pipe and flue exhaust pipe. Kit LB-49107CE (60G77) contains concentric termination assembly, mounting clamp, roof flashing, reducer bushing and 45 degree elbow. Kit requires single hole penetration of roof or wall for installation. Kit is A.G.A. certified and must be ordered extra for field installation. See dimension drawings.

**Vent/Intake Air Roof Termination Kit (Optional)** — Facilitates installation of combustion air intake pipe and flue exhaust pipe. Kit contains two neoprene rubber roof flashings and 18 inch insulation sleeve for sealing and isolating intake and exhaust piping penetration in roof. Kit LB-49107CC (15F75) must be ordered extra for field installation. See dimension drawings.

**Vent/Intake Air Wall Termination Kit (Optional)** — Facilitates installation of combustion air intake pipe and flue exhaust pipe. Kit must be ordered extra. Select one of the following:

- 1 — Kit LB-49107CB (15F74) contains 2 stainless steel outside seal caps, 2 galvanized steel inside seal caps, 4 seal rings for the caps and 18 inch insulation sleeve for sealing and isolating intake and exhaust piping penetration of wall. Maintain a maximum of 6 inches between the inlet and outlet openings in the installation of the pipes. See dimension drawings.
- 2 — Kit LB-49107CD (22G44) consists of close-couple side-by-side PVC piping with galvanized steel wall cover plate for sealing and isolating piping penetration of the wall. Piping spacing and length is sized for proper wall installations. A.G.A. certified. See dimension drawings.

## SPECIFICATIONS

Model No.		G21Q3-40	G21Q3-60	G21Q4-60
Input Btuh		40,000	60,000	60,000
Output Btuh		39,000	55,500	57,000
*A.F.U.E.		96.2%	94.1%	94.1%
California Seasonal Efficiency		90.7%	89.9%	88.8%
Temperature rise range (°F)		35 – 65	40 – 70	35 – 65
High static certified by A.G.A. (in wg.)		.50	.50	.50
Gas Piping Size I.P.S. (in.)	Natural	1/2	1/2	1/2
	**LPG	1/2	1/2	1/2
Vent/Intake air pipe size connection (in.)		2	2	2
Condensate drain connection (in.) SDR11		1/2	1/2	1/2
Blower wheel nominal diameter x width (in.)		10 x 8	10 x 8	11 x 9
Blower motor hp		1/3	1/3	1/2
Number and size of filters (in.)		(1) 16 x 25 x 1	(1) 16 x 25 x 1	(1) 16 x 25 x 1
Tons of cooling that can be added		1-1/2 – 3	1-1/2 – 3	2-1/2 – 4
Shipping weight (lbs.)		250	250	255
Number of packages in shipment		1	1	1
Electrical characteristics		120 volts – 60 hertz – 1 phase (less than 12 amps) All models		
**LPG kit (optional)		LB-83176CR (66H95)	LB-83176CE (66H97)	LB-83176CE (66H97)
Cont. Low Speed Blower Switch Kit (optional)		LB-83611A (90H79) (All models – not used with twinning kit)		
Furnace Twinning Kit (optional)		LB-63093CA (64H88) (All models)		
Cont. Low Speed Blower Switch (optional)		67H18 (All models – used with twinning kit only)		
External Filter Mounting Kit (optional)	Part No.	LB-81871CA (16H36)	LB-81871CA (16H36)	LB-81871CA (16H36)
	•Filter size (in.)	(1) 16 x 25 x 1	(1) 16 x 25 x 1	(1) 16 x 25 x 1

•Filter is not furnished with kit. Filter kit utilizes existing filter supplied with G21 unit.

\*Annual Fuel Utilization Efficiency based on D.O.E. test procedures and according to F.T.C. labeling regulations. Isolated combustion system rating for non-weatherized furnaces.

\*\*LPG kit must be ordered extra for field changeover.

## SPECIFICATIONS

Model No.		G21Q3-80	G21Q4-80	G21Q5-80	G21Q3-100	G21Q4/5-100
Input Btuh		80,000	80,000	80,000	100,000	100,000
Output Btuh		74,000	74,000	75,000	94,000	95,000
*A.F.U.E.		93.9%	93.9%	93.2%	94.0%	94.5%
California Seasonal Efficiency		90.1%	88.9%	88.3%	90.8%	89.6%
Temperature rise range (°F)		45 – 75	40 – 70	35 – 65	55 – 85	40 – 70
High static certified by A.G.A. (in wg.)		.50	.50	.50	.50	.50
Gas Piping Size I.P.S. (in.)	Natural	1/2	1/2	1/2	1/2	1/2
	**LPG	1/2	1/2	1/2	1/2	1/2
Vent/Intake air pipe size connection (in.)		2	2	2	2	2
Condensate drain connection (in.) SDR11		1/2	1/2	1/2	1/2	1/2
Blower wheel nominal diameter x width (in.)		10 x 8	11 x 9	12 x 12	10 x 8	12 x 12
Blower motor hp		1/3	1/2	3/4	1/2	3/4
Number and size of filters (in.)		(1) 16 x 25 x 1	(1) 16 x 25 x 1	(1) 20 x 25 x 1	(1) 20 x 25 x 1	(1) 20 x 25 x 1
Tons of cooling that can be added		2 – 3	2-1/2 – 4	4 or 5	2 – 3	3-1/2 – 5
Shipping weight (lbs.)		250	255	297	297	297
Number of packages in shipment		1	1	1	1	1
Electrical characteristics		120 volts – 60 hertz – 1 phase (less than 12 amps) All models				
**LPG kit (optional)		LB-83176CF (66H98)	LB-83176CF (66H98)	LB-83176CF (66H98)	LB-83176CP (73H62)	LB-83176CP (73H62)
Cont. Low Speed Blower Switch Kit (optional)		LB-83611A (90H79) (All models – not used with twinning kit)				
Furnace Twinning Kit (optional)		LB-63093CA (64H88) (All models)				
Cont. Low Speed Blower Switch (optional)		67H18 (All models – used with twinning kit only)				
External Filter Mounting Kit (optional)	Part No.	LB-81871CA (16H36)	LB-81871CA (16H36)	LB-81871CB (16H37)	LB-81871CB (16H37)	LB-81871CB (16H37)
	•Filter size (in.)	(1) 16 x 25 x 1	(1) 16 x 25 x 1	(1) 20 x 25 x 1	(1) 20 x 25 x 1	(1) 20 x 25 x 1

•Filter is not furnished with kit. Filter kit utilizes existing filter supplied with G21 unit.

\*Annual Fuel Utilization Efficiency based on D.O.E. test procedures and according to F.T.C. labeling regulations. Isolated combustion system rating for non-weatherized furnaces.

\*\*LPG kit must be ordered extra for field changeover.

## BLOWER DATA

**G21Q3-40, G21Q3-60 AND G21Q3-80  
BLOWER PERFORMANCE**

External Static Pressure (in. wg)	Air Volume @ Various Speeds		
	High	Medium	Low
0	1585	1392	920
.05	1558	1364	917
.10	1533	1354	915
.15	1505	1335	912
.20	1477	1315	905
.25	1447	1294	893
.30	1418	1272	887
.40	1355	1225	858
.50	1282	1164	803

NOTE — All cfm data is measured external to unit with the air filter in place.

**G21Q4-60 AND G21Q4-80  
BLOWER PERFORMANCE**

External Static Pressure (in. wg)	Air Volume @ Various Speeds		
	High	Medium	Low
0	1793	1295	1050
.05	1770	1290	1050
.10	1747	1285	1050
.15	1724	1280	1050
.20	1700	1275	1050
.25	1675	1267	1050
.30	1648	1258	1050
.40	1585	1233	1036
.50	1517	1193	1012

NOTE — All cfm data is measured external to unit with the air filter in place.

**G21Q5-80 BLOWER PERFORMANCE**

External Static Pressure (in. wg)	Air Volume (cfm) @ Various Speeds				
	High	Med-High	Medium	Med-Low	Low
0	2460	2350	2155	1900	1695
.05	2430	2310	2130	1875	1675
.10	2395	2275	2100	1855	1655
.15	2355	2240	2065	1825	1625
.20	2315	2205	2035	1800	1600
.25	2275	2175	1995	1780	1570
.30	2235	2130	1960	1740	1540
.40	2155	2055	1880	1675	1480
.50	2070	1970	1790	1605	1410
.60	1980	1890	1710	1540	1345

NOTE — All cfm data is measured external to unit with the air filter in place.

**G21Q3-100 BLOWER PERFORMANCE**

External Static Pressure (in. wg)	Air Volume @ Various Speeds		
	High	Medium	Low
0	1850	1660	1500
.05	1805	1635	1470
.10	1760	1610	1440
.15	1720	1575	1420
.20	1680	1540	1400
.25	1635	1505	1375
.30	1590	1470	1350
.40	1500	1400	1290
.50	1400	1320	1220
.60	1290	1230	1140

NOTE — All cfm data is measured external to unit with the air filter in place.

**G21Q4/5-100 BLOWER PERFORMANCE**

External Static Pressure (in. wg)	Air Volume (cfm) @ Various Speeds				
	High	Med-High	Medium	Med-Low	Low
0	2450	2340	2140	1910	1690
.05	2420	2310	2110	1880	1670
.10	2390	2270	2080	1860	1640
.15	2350	2240	2050	1830	1620
.20	2320	2210	2020	1800	1590
.25	2280	2170	1990	1770	1570
.30	2250	2140	1960	1740	1540
.40	2180	2060	1890	1680	1480
.50	2100	1980	1810	1610	1420
.60	2005	1890	1740	1530	1350

NOTE — All cfm data is measured external to unit with the air filter in place.

## A.G.A. INSTALLATION CLEARANCES

Sides	1 inch
Rear	1 inch
Top	1 inch
Front	1 inch
Floor	Combustible
Exhaust Pipe	0 inches
Exhaust Pipe Side	6 inches (service only)

### DIMENSIONS (inches)

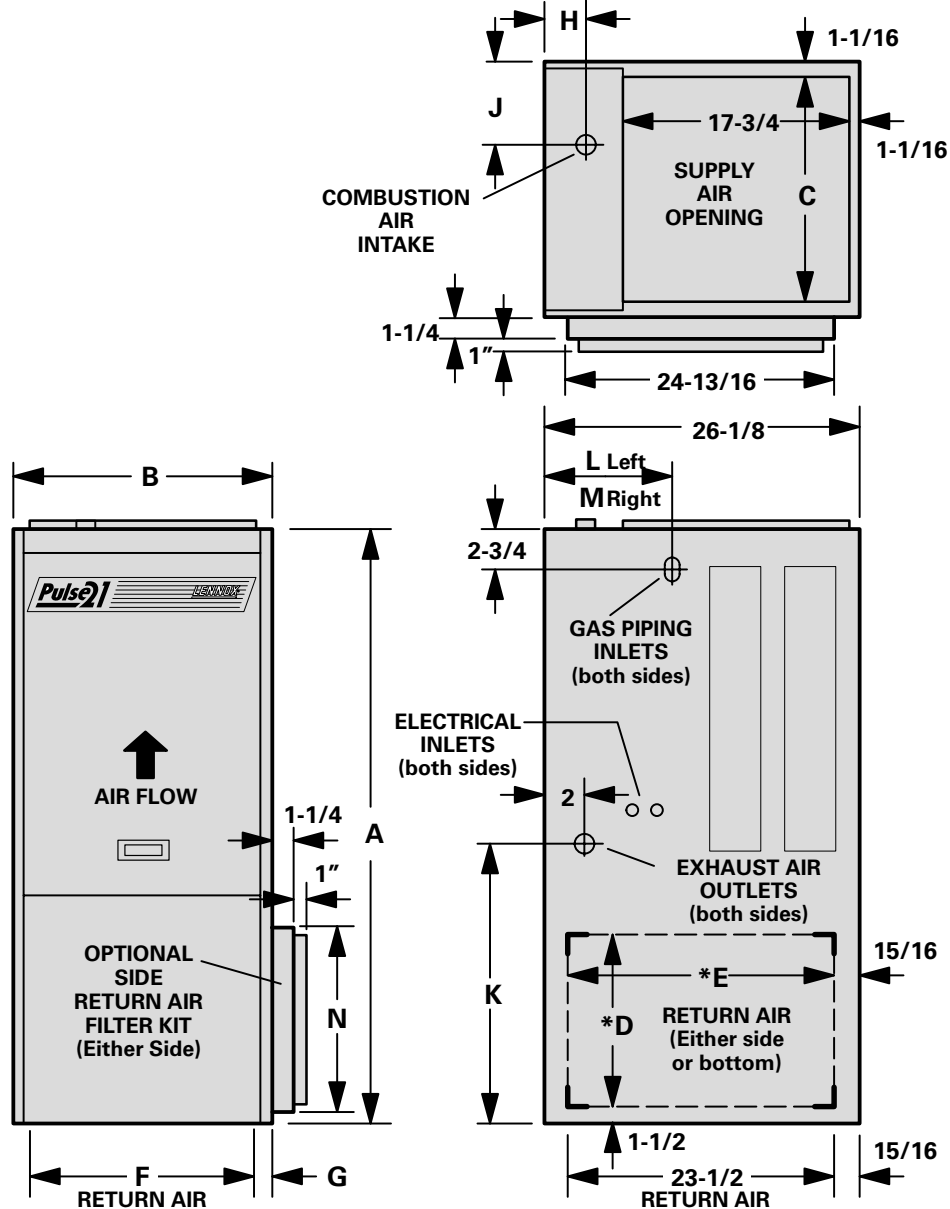

\*Unit or Optional External Side Return Air Filter Kit

Model No.	A	B	C	D	E	F	G	H	J	K	L	M	N
G21Q3-40 G21Q3-60 G21Q3-80	49	21-1/4	19-1/8	14-1/2	18-1/2	14-1/2	3-3/8	4-1/2	8-1/2	20-1/4	7-1/4	5-1/4	16
G21Q4-60 G21Q4-80	49	21-1/4	19-1/8	14-1/2	23-1/2	14-1/2	3-3/8	4-1/2	8-1/2	20-1/4	7-1/4	5-1/4	16
G21Q3-100	53	26-1/4	24-1/8	18-1/2	18-1/2	18-1/2	3-7/8	2-1/2	11	24-1/4	4-5/8	4-5/8	20
G21Q5-80 G21Q4/5-100	53	26-1/4	24-1/8	18-1/2	23-1/2	18-1/2	3-7/8	2-1/2	11	24-1/4	4-5/8	4-5/8	20

**IN-LINE MUFFLERS  
(LB-52057CA)**

NOTE — Two mufflers are furnished per order no.

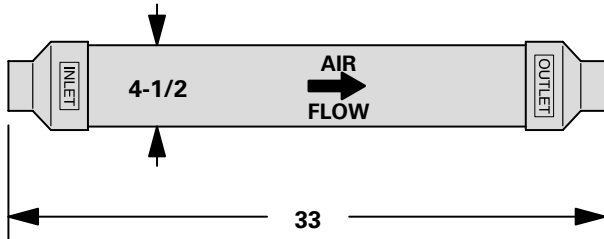

**CONCENTRIC ROOF/WALL  
TERMINATION KIT  
(LB-49107CE)**

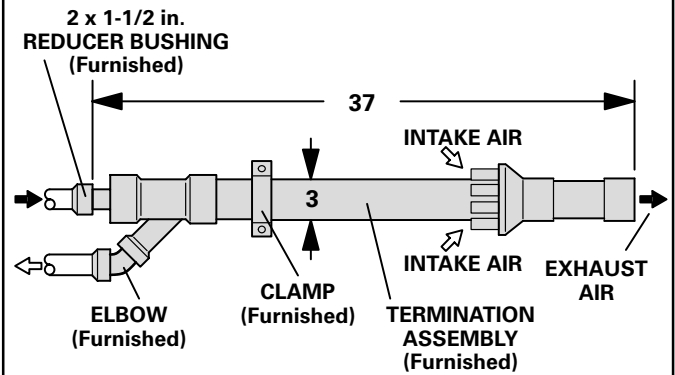

**CONCENTRIC WALL  
TERMINATION APPLICATIONS**

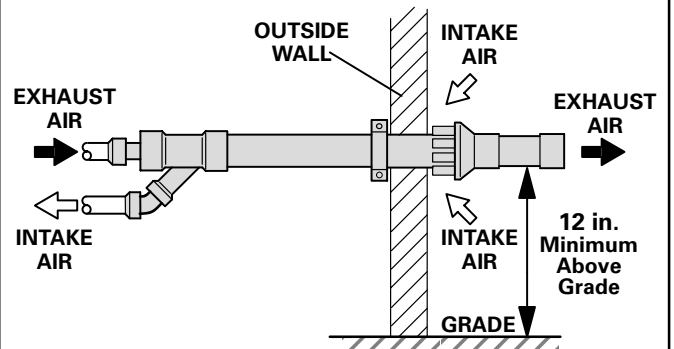

**ROOF TERMINATION KIT  
(LB-49107CC)**

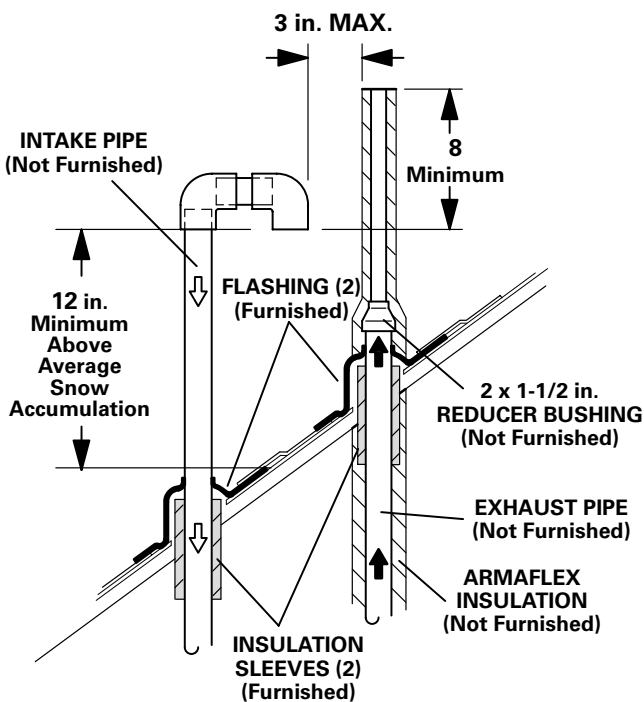

**CONCENTRIC ROOF  
TERMINATION APPLICATIONS**

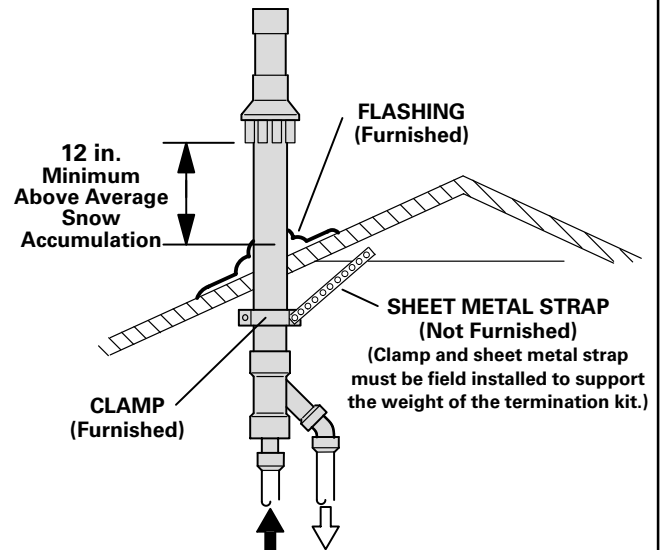

**OPTIONAL ACCESSORY DIMENSIONS (inches)**

**CLOSE-COUPLE WALL TERMINATION KIT (LB-49107CD)**

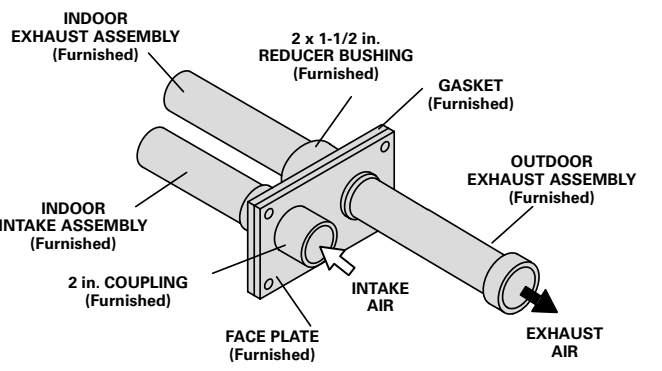

If Intake and Exhaust Pipe is less than 12 in. above snow accumulation or other obstructions, field fabricated piping must be installed.

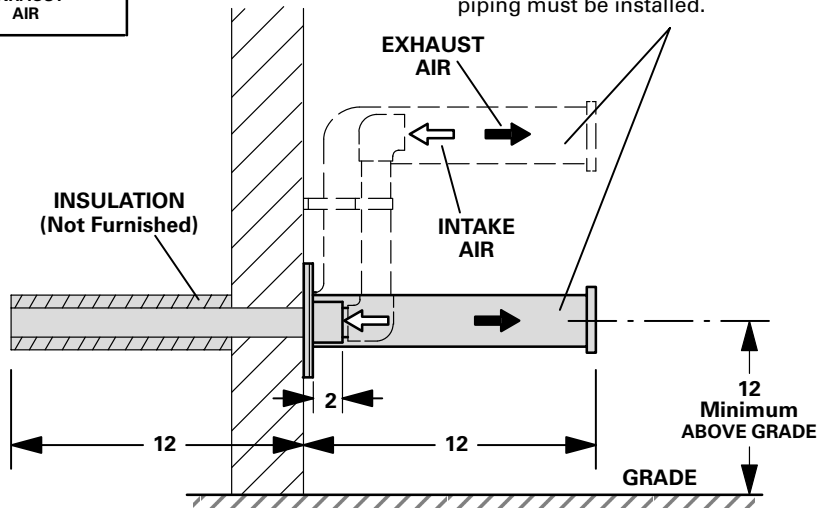
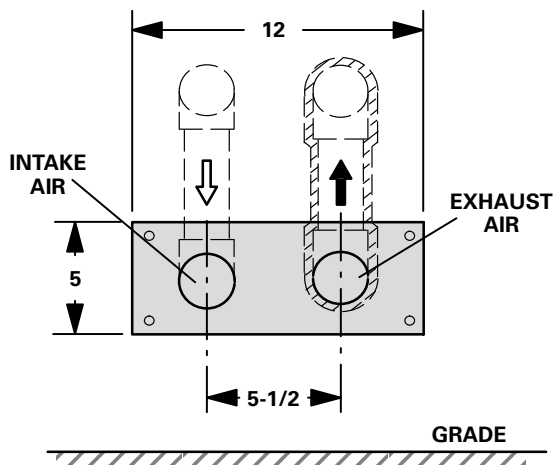

**WALL TERMINATION KIT (LB-49107CB)**

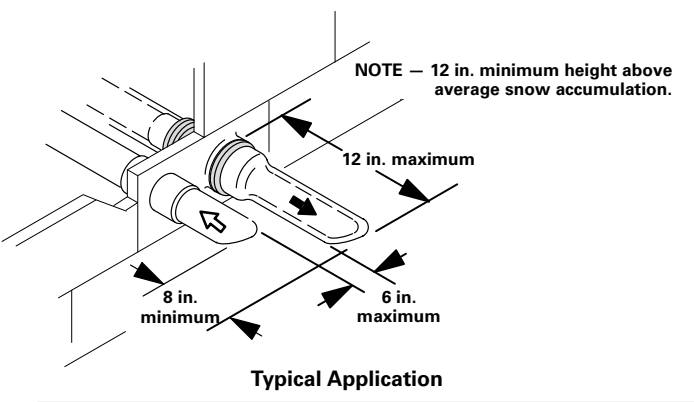

**NOTE - EXHAUST PIPE SHOWN**

INSULATION SLEEVE (2 Furnished 1 for intake and 1 for exhaust)

GALVANIZED STEEL INSIDE SEAL CAP (2 Furnished 1 for intake and 1 for exhaust)

STAINLESS STEEL OUTSIDE SEAL CAP (2 Furnished 1 for intake and 1 for exhaust)

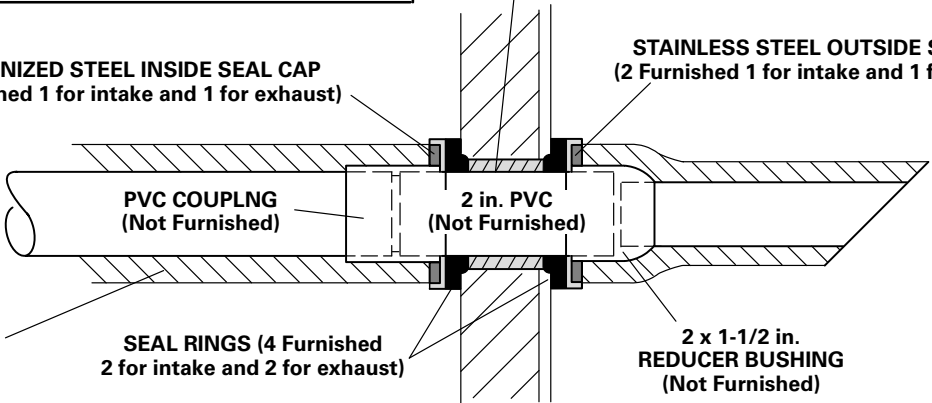

ARMAFLEX INSULATION (Not Furnished)