

LENNOX

ALL SEASON — DX COOLING & GAS HEATING GCS3 SERIES — HORIZONTAL & DOWN-FLO

*200,000 to 273,000 Btuh Total Cooling Capacity
275,000 to 500,000 Btuh Input Heating Capacity

*At ARI standard test conditions

ENGINEERING DATA
COMBINATION
UNITS
ROOFTOP
Page 37
April 1, 1981
Supersedes 10-15-79

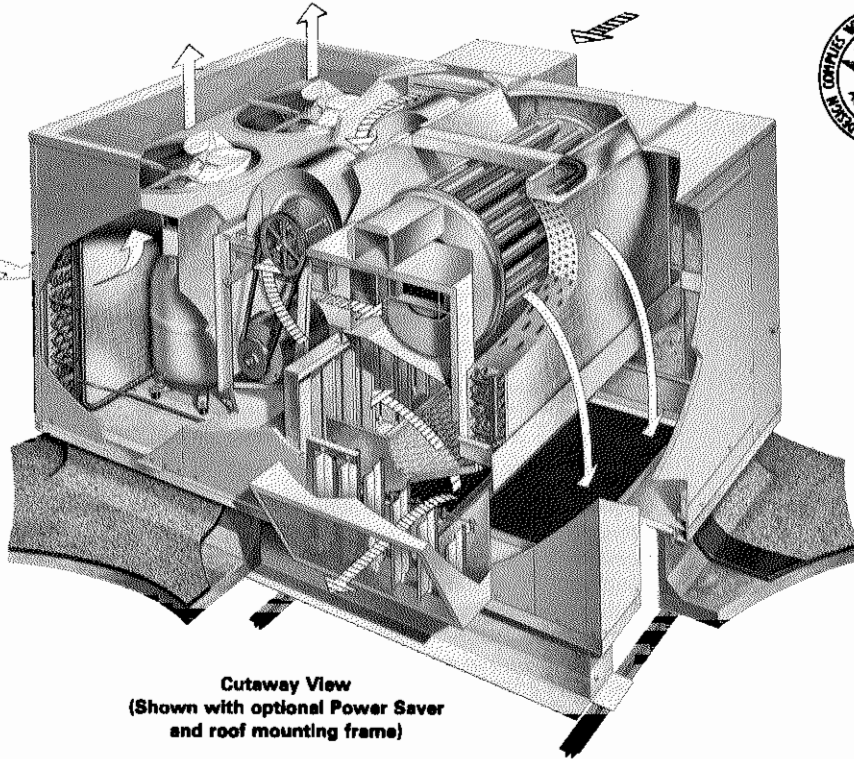

Cutaway View
(Shown with optional Power Saver
and roof mounting frame)

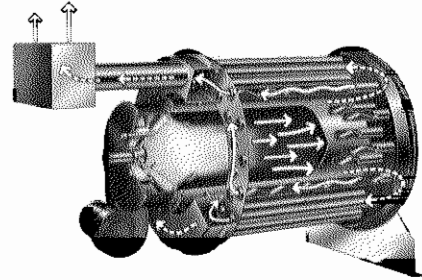

DURATUBE® Heat Exchanger

Cylindrical tube and drum designed heat exchanger constructed of aluminized steel. Round surfaces create very little air resistance. Air wipes all surfaces uniformly for excellent heat transfer. Unique design also permits expansion and contraction without undue metal fatigue. A two stage power burner using 100% secondary air gives top efficiency and extremely quiet operation.

Three Air Patterns Possible

End panels fit bottom openings to give air pattern choice. Separate adapter required for combination ceiling supply and return applications.

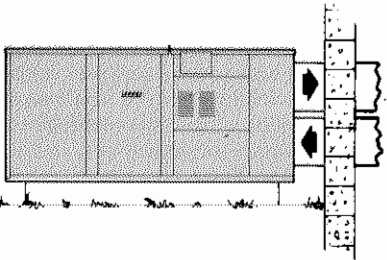

Installation thru the wall — Slab or Roof

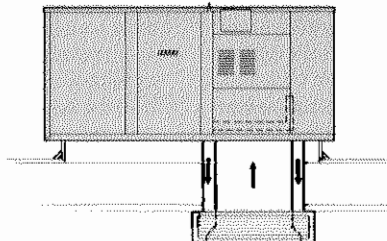

Combination Supply and Return Air Ceiling Diffuser
Step-down or Flush grille

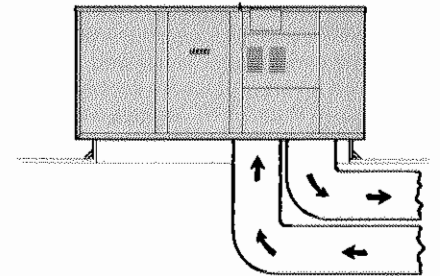

Separate Supply and Return (Double) Duct

Single Package All-Season Rooftop Unit & Mounting Frame Saves Installation Costs & Floor Space

The GCS3 series combination gas fired heating and DX cooling units with bottom handling of conditioned air, are designed primarily for rooftop installation with optional POWER SAVER® and RMF3 roof mounting frame. The separate roof frame mates to the bottom of the GCS3 unit and when flashed into the roof permits weatherproof duct connection and entry into the conditioned area. No additional roof curbing or flashing is required. The single package unit can also be installed on a slab at grade level with end handling of conditioned air. The insulated single cabinet houses air cooled DX cooling, gas fired heating, powerful belt drive blowers, air filters and the optional POWER SAVER dampers which are shipped complete with all controls wired. The aluminized DURATUBE® heat exchanger assures maximum service life and heating efficiency. Lab-

oratory life cycle testing of the heat exchanger proves long life of heating element. Gas power burner provides efficient, trouble free operation. Complete factory sealed refrigeration system consists of: compressor(s), condenser coil and fans, evaporator coil, refrigerant drier, refrigerant lines connected and a full refrigerant charge. Optional POWER SAVER equipment and controls reduce cooling costs and satisfy any local code fresh air requirements. Externally mounted OAD3 fresh air damper (auto or manual) is also available. A combination heating-cooling thermostat is furnished. Units are shipped assembled, wired and piped ready to install. Each unit is test operated on the assembly line before shipment insuring proper operation. Installer has only to set unit in desired location, connect duct work, gas supply and power supply field wiring connections.

NOTE — Specifications, Ratings and Dimensions subject to change without notice.

FEATURES

DURATUBE Heat Exchanger — Aluminized steel cylindrical tube and drum construction permits normal heat element expansion and contraction without metal fatigue. Design also results in high input to heat surface ratio, low resistance to air travel and cleanability. Flame observation port is located at rear of heat exchanger. Complete access is accomplished through removable rear breeching.

Gas Power Burner — Provides efficient, trouble free operation and is unaffected by adverse wind or atmospheric conditions. Stainless steel burner is equipped with a single combustion head. First and second stage of gas valve feeds the gas supply to the single combustion head. Combustion air blower is equipped with air pressure switch which proves blower operation, pre-purging heat exchanger, before allowing main gas valve to open. Burner has inspection glass for flame viewing, combustion air adjustment and is removable for service. The gas train consists of automatic electric solenoid valve, combination single or two stage gas valve with pressure regulator and manual main shutoff valve. Pilot flame is lit by intermittent spark and flame burns continuously during main burner operation. A pilot line combination gas valve with pressure regulator and manual shutoff valve are furnished. Gas controls provide assurance of 100% safety shutoff. Electronic flame sensing controls are standard. All controls are tested and listed for operation down to -30°F outdoor air temperature. Limit controls and electronic flame proving controls protect heating system from abnormal operating conditions. For LPG specified units (two stage only) a field conversion kit is required and must be ordered extra. See specifications table for ordering information.

Lennox Evaporator and Condenser Coils — Extra large surface area and circuiting of Lennox designed coils provide maximum cooling efficiency, excellent heat transfer and low air resistance. Lennox fabricated coils are constructed of precisely spaced ripple-edged aluminum fins fitted to durable copper tubes. Flared shoulder tubing connections and silver soldering provide tight, leakproof joints. Long life copper tubing is easy to field service. Coil is factory tested under high pressure to insure leakproof construction.

Dependable Lennox Compressors — Units are equipped with twin Lennox L2 compressors. The large casing, spring loaded discharge valve, high suction intake ports and crankcase heater result in effective "slugging" protection. Crankshaft is statically and dynamically balanced and has patented 3 mode oil pumping for positive pressure lubrication. Contoured piston for increased volumetric efficiency. Strategically located discharge mufflers result in extremely quiet operation. Motor is located within refrigerant flow pattern resulting in low motor winding temperatures. Twin internally mounted motor in-winding temperatures sensing thermostats provide safe operation. High and low pressure controls (automatic reset) are provided and factory installed in compressor terminal box. In addition a low ambient cut-out thermostat prevents compressor operation below 22F. The entire running gear assembly is spring mounted within the sealed housing and the compressor is installed in the unit on resilient rubber mounts assuring quiet and vibration free operation.

Efficient Condensing Section — Direct drive fans draw large air volumes through the extra large condenser coil(s) and discharges the air out the top. Condenser discharge grille is furnished.

Powerful Blowers — Twin resiliently mounted blowers deliver large air volumes with low power consumption. Blower motor support allows quick belt adjustment and motor changeover.

Rugged Cabinet — Heavy gauge galvanized hot dipped steel cabinet panels. A five station wash metal preparation assures a perfect bonding surface for the finish coat of baked enamel. Large removable panels provide complete service access to interior.

Thick Interior Insulation — All of the interior panels where conditioned air is handled and the base section is lined with thick fiberglass insulation.

Cleanable Air Filter — 1" frame filters are furnished as standard. Media is washable or vacuum cleanable polyurethane. Filters are easily accessible for cleaning and are coated with oil for increased efficiency. Use RP products filter coating No. 418 (P-8-5069) when recoiling. Filter rack will receive 2" filters.

Heat - Cooling Thermostat Furnished — Combination single or two stage heat and two stage cool thermostat has temperature setting dial, system selector switch and blower selection switch for intermittent or continuous blower operation.

Optional Nite Setback Controls — A nite thermostat (P-8-8899), subbase (P-8-8889) and adapter plate (P-8-8954) (to adapt to vertical outlet box) is available. Two nite setback kits are available: BM-4762 includes a manual nite setback switch and stainless steel mounting plate. Kit BM-4761 includes a manual set 12 hour nite setback timer and a stainless steel mounting plate. Mounting plate mounts to two standard electrical outlet boxes, furnished by installer. A optional 24 hour skip day clock (P-8-3744 with carryover or P-8-4168 less carryover) to program the unit automatically is available. Clock is recommended to be used with the BM-4761 kit and is optional for use with kit BM-4762. In addition, a 7 day time clock (P-8-6858 less carryover or P-8-10213 with carryover) is also available as options.

Optional Remote Readout Panel — Readout Panel (BM-5358) and Rough-In Box (BM1-5358) must be ordered extra. See bulletin (page 71) in Accessories Section. When panel is used for nite setback operation the following controls must be used and ordered extra; nite thermostat (P-8-8899), subbase (P-8-8889), adaptor plate (P-8-8954) and 24 hour skip day clock (P-8-3755 with carryover or P-8-4168 less carryover). In addition, a 7 day time clock (P-8-6858 less carryover or P-8-10213 with carryover) is also available as options.

Optional End Supply & Return Air Discharge Kit — Available for field conversion from bottom supply and return air handling to end supply and return air pattern. Kit contains divider panel(s), fasteners and instructions. See Accessories table for ordering data.

Optional Combination Supply and Return Diffusers — Lennox offers two different styles of air diffusers. The RTD step-down model extends below the ceiling level and discharges conditioned air out through grilles on all four sides. The FD model installs almost flush with the ceiling and discharges air down and out through the outside vanes. Both models are equipped with adjustable vanes for distribution and diffusion of conditioned air. Return air enters through the center grille on both models.

Optional Power Saver (Fresh Air) — Available factory or field installed. The Lennox POWER SAVER system consists of: mechanically linked outdoor air, recirculated air and exhaust air dampers. The positioning of these dampers is accomplished by a 24 volt modulating spring return damper motor and controlled by the room thermostat, adjustable mixed air controller, adjustable compressor monitor and enthalpy control. The enthalpy control senses the total heat content of the outdoor air. This unique control prevents excessive moisture laden outdoor air from entering the unit and yet permits cool dry air capable of "free" cooling to enter. For field installation the two damper sections simply slide in cavities provided in the unit cabinet. Equipment is shipped factory wired and only requires simple plug-in connection for operation. Fresh air intake section is furnished with cleanable polyurethane air filters. See Accessories table for ordering data.

Optional Minimum Fresh Air Damper — Externally mounted OAD3 fresh air damper section complete with cleanable polyurethane air filters is available. See the Accessories table. It can be either manually or automatically controlled with the addition of a damper motor.

Optional Roof Mounting — Durable and serviceable frame is 13 inches high. It sets on the roof support members and is actually built into the roof structure. The top mates to the GCS3 base. A securing bolt kit (BM-6909), containing bolts to secure unit to frame, is available as optional equipment and must be ordered extra.

Optional Low Ambient Controls — System will operate satisfactory down to 35F outdoor air temperature without additional controls. If air conditioning operation is required at outdoor air temperatures colder than 35F a field installed low ambient control kit is required. See Accessories table for ordering data.

Thoroughly Tested and Approved — A.G.A. certified as a combination heating-cooling unit for outdoor installation. Complies with ANSI safety codes. The cooling system has been thoroughly tested and rated in the Lennox environmental test room at ARI Standard test conditions. Units and components within are bonded for grounding to meet safety standards for servicing required by U.L. and NEC.

SPECIFICATIONS

Model Number		GCS3-1853-275	GCS3-1853-500	GCS3-2753-275	GCS3-2753-500
Single Stage Heating Capacity Natural Gas Only	Btuh Input	275,000	----	275,000	----
	Btuh Output	206,250	----	206,250	----
	A.G.A. Thermal Efficiency	75.0%	----	75.0%	----
Two Stage Heating Capacity Natural & †LPG	Btuh Input (low)	----	275,000	----	275,000
	Btuh Output (low)	----	206,250	----	206,250
	Btuh Input (high)	----	500,000	----	500,000
	Btuh Output (high)	----	375,000	----	375,000
	A.G.A. Thermal Efficiency	----	75.0%	----	75.0%
**Cooling Capacity @ARI Standard Conditions	Total capacity (Btuh)	200,000		273,000	
	Total unit watts	25,000		35,500	
	*EER (Btuh/Watt)	8.0		7.7	
	Dehumidifying capacity	29%		26%	
★SRN @ ARI Standard Conditions		23		23	
Refrigerant charge (R-22)		40 lbs.		48 lbs.	
Blower wheel nom. diam. x wid. (in.)		(2) 15 x 11		(2) 15 x 15	
Blower Motor hp (Min. — Max.)		3 — 5		5 — 7-1/2	
Condenser Coil	Net face area (sq. ft.)	(2) 10.75		(2) 12.15	
	Tube diam. (in.) & No. of rows & fins	1/2 — 4 — 13		1/2 — 6 — 13	
Condenser Fan	Diam. (in.) & No. of blades	(2) 25-1/2 — 6		(2) 25-1/2 — 6	
	Motor hp	(2) 1		(2) 1	
Evaporator Coil	Net face area (sq. ft.)	(2) 7.67		(2) 8.75	
	Tube diam. (in.) & No. of rows & fins	1/2 — 4 — 10		1/2 — 4 — 13	
No. & size of filters (in.) Washable polyurethane filter media		(4) 16 x 20 x 1 (4) 20 x 20 x 1		(8) 20 x 20 x 1	
Gas supply connection MPT (in.) Natural & †LPG		1-1/4		1-1/4	
Condensate drain size MPT (in.)		1-1/4		1-1/4	
Net Weight of basic unit		3185		3730	

★Sound Rating Number in accordance with ARI Standard 270.

**Rated in accordance with ARI Standard 210; 450 cfm (maximum) evaporator air volume per ton of cooling, 95F outdoor air temperature and 80db/67wb entering evaporator air.

*Energy Efficiency Ratio in accordance with ARI Standard 210.

†For LPG models a field conversion kit (91A21) is required and must be ordered extra.

ACCESSORIES

Accessory Description	Accessory No. & Net Weight (lbs.)	
	GCS3-1853	GCS3-2753
	POWER SAVER and No. & size of filters (in.)	RD3-185 (510 lbs.) (3) 20 x 36 x 1
Minimum fresh air damper and No. & size of filters (in.)	OAD3-185 (101 lbs.) (1) 25 x 27 x 1	OAD3-275 (107 lbs.) (1) 26 x 31 x 1
Automatic Kit for OAD3 Damper	BM-5563 (9 lbs.)	BM-5563 (9 lbs.)
RP2-1 Remote Readout Panel	BM2-5358 (5 lbs.)	BM2-5358 (5 lbs.)
RP2-00-1 - Rough-in Box	BM1-5358 (3 lbs.)	BM1-5358 (3 lbs.)
Remote Readout Panel Kit	BM-5817 (5 lbs.)	BM-5817 (5 lbs.)
Low Ambient Control Kit	LB-80249BA (8 lbs.)	LB-80249BA (8 lbs.)
Roof Mounting Frame	RMF3-185/275 (200 lbs.)	RMF3-185/275 (200 lbs.)
Combination Ceiling Supply and Return Kit	BM-3566 (40 lbs.)	BM-3567 (43 lbs.)
Combination Ceiling Supply And Return Step Down Diffuser	RTD-185/275 (172 lbs.)	RTD-185/275 (172 lbs.)
Combination Ceiling Supply And Return Flush Diffuser	FD-185 (64 lbs.) *FD-185-D (64 lbs.)	FD-275 (69 lbs.) *FD-275-D (69 lbs.)
End Supply & Return Air Discharge Kit	LB-44878CA (20 lbs.)	LB-44877CA (25 lbs.)

*Flush diffuser with adjustable baffles blades.

RATINGS

Unit Model No.	Evaporator Air 80F Dry Bulb		Outdoor Air Temperature Entering Condenser (F)											
	Entering Wet Bulb Degrees (F)	Total Air Volume (Cfm)	85			95			105			115		
			Total Cooling Capacity (Btuh)	Sensible to Total Ratio (S/T)	Comp. Motor Watts Input	Total Cooling Capacity (Btuh)	Sensible to Total Ratio (S/T)	Comp. Motor Watts Input	Total Cooling Capacity (Btuh)	Sensible to Total Ratio (S/T)	Comp. Motor Watts Input	Total Cooling Capacity (Btuh)	Sensible to Total Ratio (S/T)	Comp. Motor Watts Input
GCS3-1853	63	6000	191,600	.84	17,000	181,400	.86	18,400	170,800	.90	19,900	160,100	.93	21,300
		6750	195,500	.87	17,100	185,000	.90	18,600	174,000	.93	20,100	162,900	.96	21,500
		7500	199,100	.89	17,300	188,300	.92	18,800	177,100	.95	20,300	165,700	.98	21,600
	67	6000	206,600	.67	17,800	195,800	.69	19,300	184,600	.71	10,800	173,100	.73	22,200
		6750	210,900	.69	18,000	199,800	.71	19,500	188,200	.73	21,000	176,300	.75	22,400
		7500	214,900	.71	18,200	203,400	.72	19,700	191,300	.74	21,200	179,200	.76	22,800
	71	6000	222,200	.52	18,600	210,600	.53	20,200	198,300	.54	21,600	186,100	.55	23,000
		6750	226,400	.53	18,900	214,500	.54	20,400	201,800	.55	22,000	189,100	.56	23,200
		7500	230,400	.54	19,100	218,100	.55	20,600	205,000	.56	22,000	192,000	.56	23,500
GCS3-2753	63	8800	261,000	.89	25,100	248,000	.92	26,600	235,000	.94	28,100	222,000	.98	30,000
		9900	266,500	.92	25,300	252,500	.95	26,800	239,200	.97	28,400	225,500	1.00	30,300
		8800	282,600	.70	26,000	268,000	.72	27,700	254,000	.74	29,400	239,400	.76	31,500
	67	9900	288,500	.73	26,400	273,000	.75	28,000	258,000	.76	29,700	242,700	.78	31,800
		8800	304,500	.54	27,300	288,000	.55	29,000	272,000	.56	30,800	255,800	.58	32,900
		9900	309,800	.55	27,600	292,600	.56	29,300	276,000	.58	31,200	259,500	.59	33,200

HIGH ALTITUDE DERATE

If the heating value of the gas does not exceed values listed in table, derating of unit is not required. Should the heating value of the gas exceed the table values, or if the elevation is greater than 6,000 feet above sea level it will be necessary to derate unit. Lennox requires that derate conditions be 4% per thousand feet above sea level. Thus at an altitude of 4000 feet, if the heating value of the gas exceeds 1000 Btu/ft³, the unit will require a 16% derate.

Elevation Above Sea Level (Feet)	Maximum Heating Value (Btu/ft ³)
5001 — 6000	900
4001 — 5000	950
3001 — 4000	1000
2001 — 3000	1050
Sea Level — 2000	1100

ELECTRICAL DATA

Model No.	GCS3-1853				GCS3-2753					
	208/230		460		208/230		460			
Line Voltage (60 hertz — 3 phase)	208/230		460		208/230		460			
Compressor(s)	Rated Load Amps (total)		64.6		29.2		85.6		41.2	
	Locked Rotor Amps (total)		370.0		186.0		480.0		256.0	
Condenser Fan Motors (2)	Full Load Amps (total)		8.6		4.3		8.6		4.3	
	Locked Rotor Amps (total)		40.0		20.0		40.0		20.0	
Evaporator Blower Motor	Horsepower		3	5	3	5	5	7-1/2	5	7-1/2
	Full Load Amps		10.6	16.7	4.8	7.6	16.7	24.2	7.6	11.0
	Locked Rotor Amps		64.0	92.0	32.0	46.0	92.0	140.0	46.0	70.0
Recommended Maximum Fuse Size (amps)			110	125	50	60	150	150	70	80
Unit Power Factor			.85	.85	.85	.85	.85	.85	.85	.85
†Minimum Circuit Ampacity			91.9	98.1	44.3	47.1	121.6	129.1	58.3	61.7

†Refer to National Electrical Code manual to determine wire, fuse and disconnect size requirements.

NOTE — Extremes of operating range are plus and minus 10% of line voltage.

FIELD WIRING

- A — *Five wire low voltage (Single Stage Cool and Two Stage Heat)
(Two Stage Cool and Single Stage Heat)
- *Six wire low voltage (Two Stage Cool and Two Stage Heat)
- *If POWER SAVER and Nite Setback controls are used one additional wire is required.

- B — Three wire power (See Electrical Data Table)
- C — Two wire low voltage
- D — Two wire low voltage (Without POWER SAVER)
- Three wire low voltage (With POWER SAVER)

Additional field wiring is not required when POWER SAVER is used. All wiring is provided in GCS3 and in Power Saver, simply make plug-on connections to complete job for field installations.

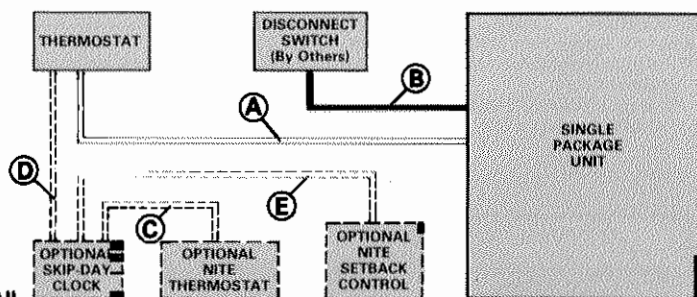

All wiring must conform to NEC and local electrical codes.

INSTALLATION CLEARANCES (inches)

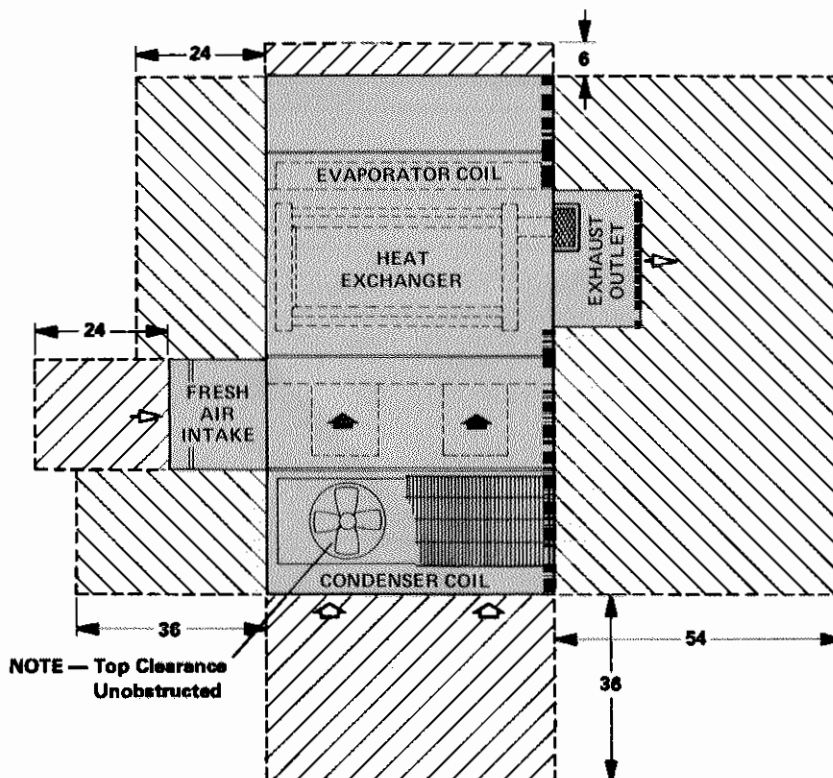

DIMENSIONS (inches)

CENTER OF GRAVITY (in.)

Model No.		N	O
GCS3-1853	With Power Saver	42	55
	Without Power Saver	39	54-1/2
GCS3-2753	With Power Saver	43-1/2	54-1/2
	Without Power Saver	40	54

CORNER WEIGHTS (lbs.)

Model No.		P	Q	R	S
GCS3-1853	With Power Saver	751	734	1091	1119
	Without Power Saver	595	672	1017	901
GCS3-2753	With Power Saver	904	821	1243	1368
	Without Power Saver	709	762	1170	1089

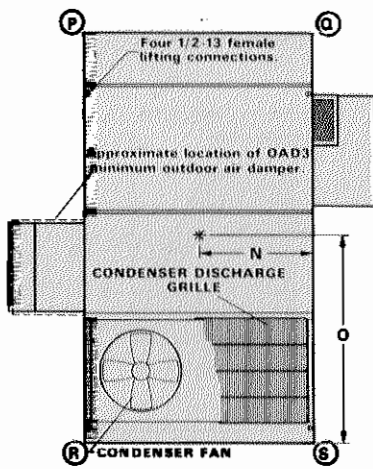

TOP VIEW

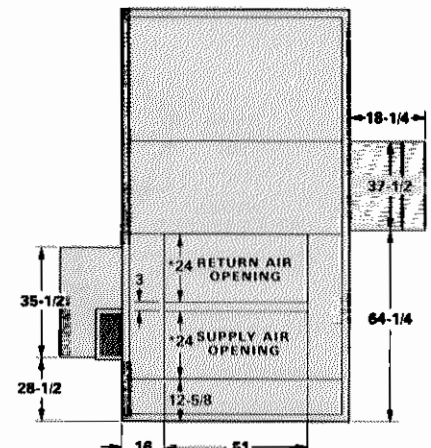

BOTTOM VIEW (Looking Down)

The air opening panels furnished fit either end or bottom openings to give choice of bottom or end handling of conditioned air.

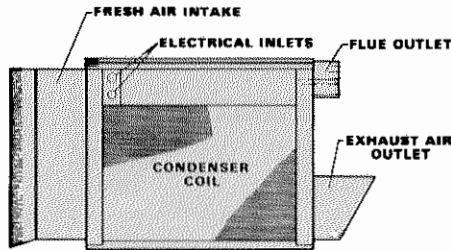

CONDENSER END

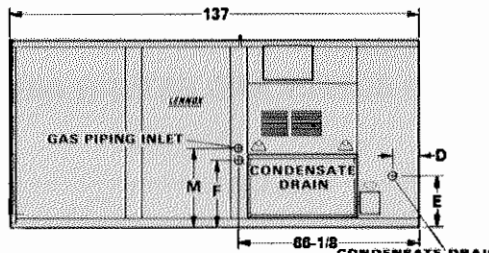

SIDE VIEW

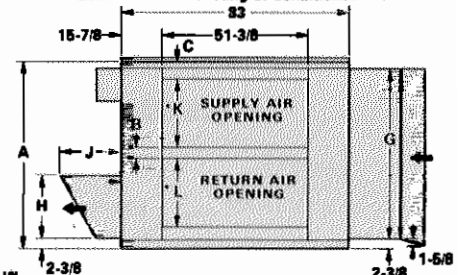

SUPPLY & RETURN END

Model No.	A	B	C	D	E	F	G	H	J	K	L	M
GCS3-1853	52-5/8	1	1-1/2	15-1/2	17	18-1/2	48-3/4	15-3/4	15-5/16	23-3/8	23-3/8	20-7/8
GCS3-2753	62-5/8	6-3/8	2-3/8	16-3/16	22-5/16	27	58-3/4	24-1/8	20-1/8	24-3/8	24-3/8	29-1/4

RMF3 ROOF MOUNTING FRAME

Frame Specifications

Mounting Frame Height	13 Inches
Frame moment of inertia (I)	70 in. ⁴
Frame section modulus $\frac{I}{C}$	10.8 in. ³
Mounting frame weight (foot of length)	5.3
Mounting frame design strength (psi)	20,000

Roof Mounting frame is rigid enough to be spanned over its entire length or cantilevered if supported on either side of the center of gravity. The side joint plate must be welded to the RMF3-185/275 frame if it is spanned more than 80 inches or cantilevered more than 40 inches.

Mounting Frame with Combination Ceiling Supply & Return Opening

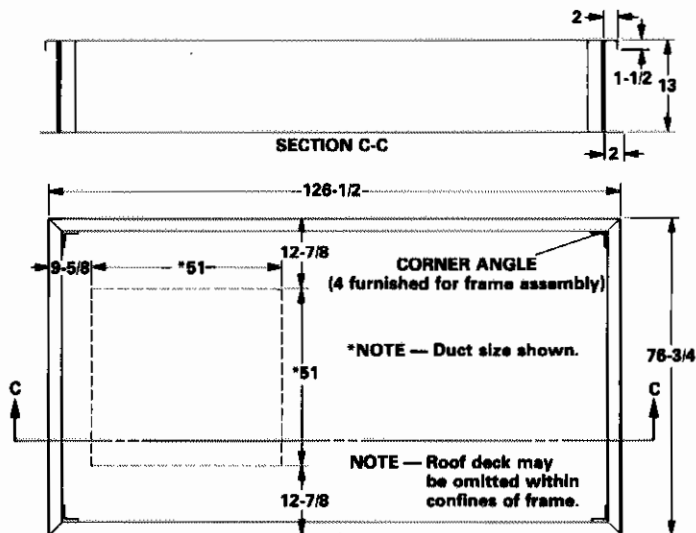

Mounting Frame with Double Duct Openings

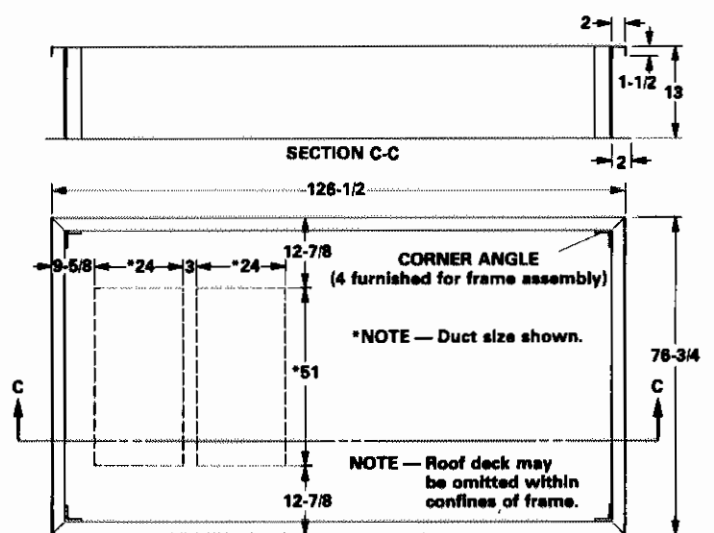

RECOMMENDED FLASHING FOR RMF3 ROOF MOUNTING FRAME

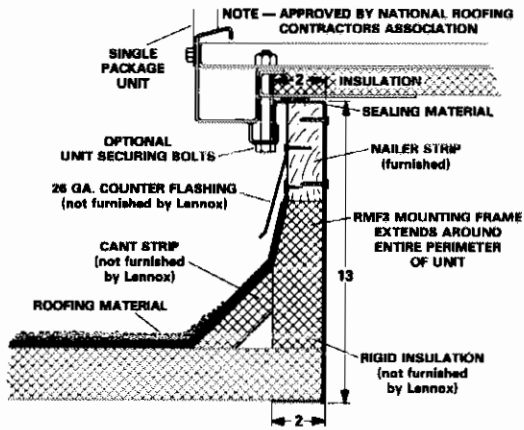

OAD3 SERIES DAMPER ASSEMBLY (Optional)

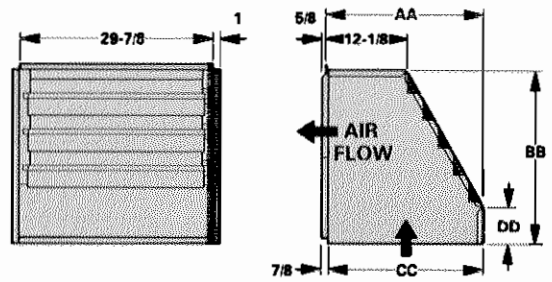

Unit	AA	BB	CC	DD
OAD3-185	22-1/4	27-1/2	22	10-3/4
OAD3-275	24-1/4	33-1/4	24	12-1/4

COMBINATION CEILING SUPPLY AND RETURN AIR DISTRIBUTION SYSTEM

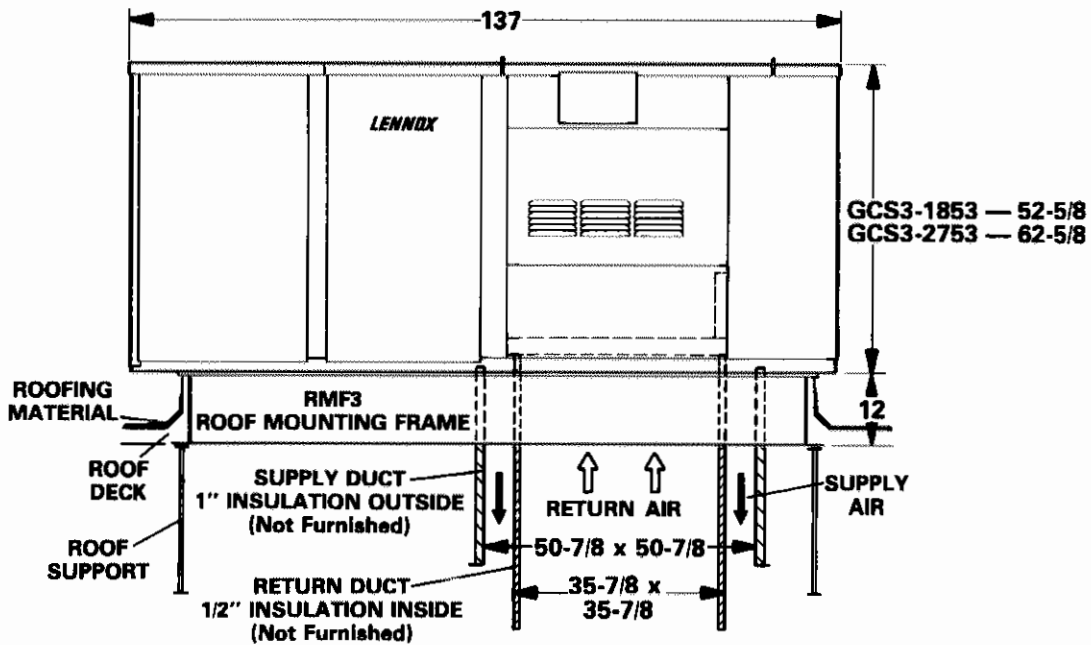

CEILING DIFFUSERS

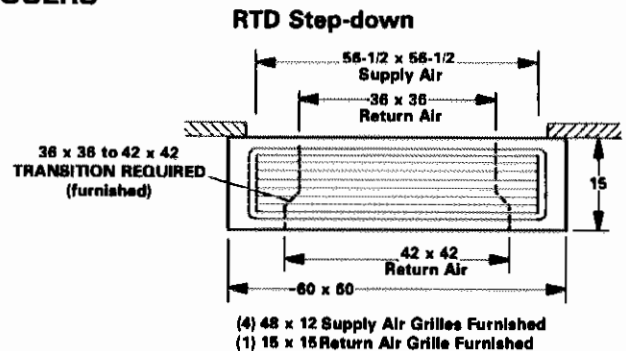
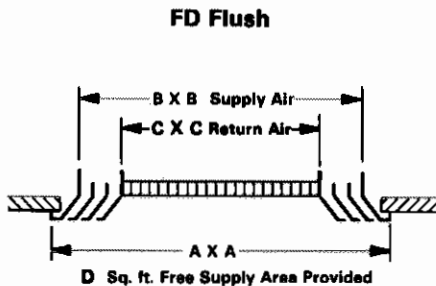

Unit Model No.	Supply and Return Air Grille Model No.	A	B	C	D
GCS3-1853	FD-185 Flush	56-3/4	51	36	9.06 sq. ft.
	FD-185-D Flush (Adj. Baffle Blades)				
GCS3-2753	FD-275 Flush	68-3/4	63	45	13.50 sq. ft.
	FD-275-D Flush (Adj. Baffle Blades)				

BLOWER DATA

GCS3-1853 BLOWER PERFORMANCE CHART

Air Volume (Cfm)	STATIC PRESSURE EXTERNAL TO UNIT (Inches Water Gauge)																					
	0		.10		.20		.30		.40		.50		.60		.70		.80		.90		1.0	
	RPM	BHP	RPM	BHP	RPM	BHP	RPM	BHP	RPM	BHP	RPM	BHP	RPM	BHP	RPM	BHP	RPM	BHP	RPM	BHP	RPM	BHP
5000	490	.95	530	1.15	570	1.30	605	1.40	635	1.55	670	1.70	700	1.85	730	2.00	760	2.15	785	2.30	815	2.50
5500	540	1.30	575	1.45	615	1.65	645	1.80	675	1.95	705	2.10	735	2.25	765	2.40	790	2.60	820	2.80	840	2.95
6000	590	1.70	620	1.85	650	2.00	685	2.20	715	2.40	740	2.60	775	2.80	800	3.00	825	3.15	850	3.30	875	3.50
6500	640	2.15	670	2.35	700	2.55	725	2.70	750	2.85	780	3.05	810	3.30	835	3.50	860	3.65	885	3.85	910	4.10
7000	685	2.65	715	2.90	740	3.10	770	3.30	800	3.50	825	3.70	850	3.90	875	4.15	900	4.35	920	4.55	940	4.75
7500	735	3.25	765	3.45	790	3.70	815	3.95	840	4.15	865	4.35	890	4.60	910	4.80	930	5.00	955	5.25	980	5.55

NOTE — All cfm data is measured external to the unit using standard return air opening and with filters in place.

GCS3-2753 BLOWER PERFORMANCE CHART

Air Volume (Cfm)	STATIC PRESSURE EXTERNAL TO UNIT (Inches Water Gauge)																					
	0		.10		.20		.30		.40		.50		.60		.70		.80		.90		1.0	
	RPM	BHP	RPM	BHP	RPM	BHP	RPM	BHP	RPM	BHP	RPM	BHP	RPM	BHP	RPM	BHP	RPM	BHP	RPM	BHP	RPM	BHP
6500	530	1.40	570	1.60	605	1.80	640	1.95	675	2.15	705	2.35	730	2.55	760	2.75	785	2.95	810	3.10	835	3.30
7000	570	1.80	605	1.95	640	2.15	675	2.35	705	2.55	735	2.75	760	2.95	790	3.15	815	3.35	840	3.55	865	3.85
7500	615	2.20	645	2.40	675	2.60	705	2.80	735	3.00	765	3.20	795	3.45	820	3.65	845	3.90	870	4.10	895	4.35
8000	650	2.65	680	2.85	715	3.10	745	3.30	770	3.50	800	3.75	825	3.95	850	4.20	875	4.45	900	4.70	920	4.90
8500	690	3.15	720	3.40	750	3.65	780	3.85	805	4.10	830	4.30	855	4.55	880	4.80	905	5.10	930	5.35	950	5.55
9000	730	3.80	760	4.05	790	4.30	815	4.50	840	4.75	865	5.05	890	5.25	915	5.50	940	5.80	960	6.05	980	6.25
9500	775	4.55	800	4.75	825	5.00	850	5.20	875	5.45	900	5.75	925	6.05	950	6.30	970	6.55	990	6.80	1015	7.15
10,000	815	5.25	840	5.50	860	5.70	885	6.00	915	6.30	935	6.55	960	6.85	980	7.15	1000	7.40	1020	7.65	1040	7.95

NOTE — All cfm data is measured external to the unit using standard return air opening and with filters in place.

DRIVE SELECTION

Model No.	Nominal Motor Hp	Maximum Usable Hp	*Rpm Range Of All Available Drive Setups @ 1720 Rpm Motor Speed
GCS3-1853	3	3.45	720-875
	5	5.75	815-970
GCS3-2753	5	5.75	740-890
	7-1/2	8.63	830-980

*Specify exact Bhp, Rpm and power characteristics required when ordering unit. In Canada nominal horsepower is maximum usable horsepower.

ACCESSORY PRESSURE DROP

Model No.	Air Volume (cfm)	Power Saver	Total Pressure Drop (Inches water gauge)				FD Ceiling Supply & Return
			RTD Combination Ceiling Supply and Return			FD Ceiling Supply & Return	
			2 Sides Open	3 Sides Open	4 Sides Open		
GCS3-1853	5000	.02	.555	.465	.425	.22	
	5500	.02	.64	.53	.475	.27	
	6000	.03	.73	.605	.54	.32	
	6500	.03	.84	.685	.60	.37	
	7000	.04	.95	.78	.67	.42	
	7500	.04	1.06	.86	.74	.47	
GCS3-2753	6500	.00	.45	.39	.35	.17	
	7000	.00	.53	.44	.39	.20	
	7500	.00	.64	.50	.44	.24	
	8000	.00	.79	.58	.51	.29	
	8500	.00	----	.69	.60	.34	
	9000	.00	----	.85	.70	.38	
9500	.00	----	----	.81	.43		
10,000	.00	----	----	.94	.49		

NOTE — POWER SAVER has no appreciable pressure drop with GCS3-2753.
NOTE — Pressure drop includes grille and 3' of ductwork.

CEILING SUPPLY AIR THROW DATA

Model No.	Air Volume (cfm)	Radius of Diffusion (Feet)	
		*RTD Step Down	**Flush
GCS3-1853	6000	40	30
	6750	44	34
	7500	47	38
GCS3-2753	8800	51	33
	9900	55	37

*Four sides open and terminates at a point where conditioned air reaches a velocity of 50 fpm at the ceiling.
**Four sides open and terminates at a point where conditioned air reaches a velocity of 35 fpm at the ceiling.

FD CEILING DIFFUSER RECOMMENDED MAX. AIR FLOW

Ceiling Height (feet)	8	9	10	12	15	20
Air Flow (cfm) per side	200	350	550	900	1500	4000

NOTE — This data is based on differentials between 15 and 25 degrees.

Prepared for the guidance of architects, consulting engineers and mechanical contractors.

General — Furnish and install a single package combination air to air DX mechanical cooling system and gas fired heating system, complete with automatic controls. The single package unit shall be a standard product of a firm regularly engaged in the manufacture of heating-cooling equipment. The manufacturer shall have parts and service available throughout the United States.

The installed weight shall not be more lbs. Entire unit shall have a width of not more than inches, a depth of not more than inches and an overall height of not more than inches. The equipment shall be shipped completely factory assembled, precharged, piped and wired internally ready for field connections. In addition, manufacturer shall test operate system at the factory before shipment.

Roof Mounting Frame — Furnish and install a steel roof mounting frame. It shall mate to the bottom perimeter of the equipment. When flashed into the roof it shall make a unit mounting curb and provide weatherproof duct connection and entry into the conditioned area. Flashing shall be the responsibility of a roofing contractor. Frame shall be approved by National Roofing Contractors Association.

Air Distribution — Equipment shall be capable of bottom or end handling of conditioned air. All air distribution ducts shall be fiberglass or ga. galvanized steel insulated with inch thick lb. density fiberglass or equivalent.

Furnish and install a (flush or stepdown) optional combination ceiling supply and return air grille. It shall be capable of not less than ft. radius of effective throw.

POWER SAVER — Furnish and install complete with controls an optional air mixing damper assembly including outdoor air, recirculated air and exhaust air dampers. The assembly shall mount within the confines of the unit cabinet and provide for the introduction of outside air for minimum ventilation and free cooling. Fresh air intake with air filter shall mount external to the cabinet. The damper motor shall be 24 volt, modulating, three position spring return. Controls shall include adjustable mixed air controller, adjustable compressor monitor and enthalpy control.

Minimum Fresh Air Damper — Optional equipment shall be available to control outdoor air requirements only. Outdoor air damper assembly shall be available for manual or automatic operation. Dampers shall be adjustable for air quantity requirements. Shall include externally mounted rain hood with air filter.

Cooling System — The total certified cooling capacity shall not be less than Btuh with an evaporator air volume of cfm, an entering wet bulb air temperature of F, an entering dry bulb air temperature of F and a condenser entering temperature of F. The compressor power input shall not exceed kW at these conditions.

The coils shall be non-ferrous construction with aluminum fins mechanically bonded to durable copper tubes. Coils shall be pressure leak tested. Coil face area shall be not less than sq. ft. (evaporator) and sq. ft. (condenser). Condenser coil(s) shall have sub-cooling rows.

The compressor(s) shall be resiliently mounted, have built-in 3 mode crankshaft lubrication, crankcase heater, discharge temperature limiter, current and temperature sensing motor overloads. The cooling system shall be protected by high and low pressure switches and a five minute compressor timed off cycle controller. Control options available shall consist of low ambient controls. Shall comply with ARI standard 210 Test Conditions.

Heating System — The heating capacity output shall be Btuh with a gas input of Btuh. Automatic controls furnished shall give 50/50 two stage operation.

Cylindrical tube and drum exchanger shall be constructed of aluminized steel. Stainless steel power burner shall use 100% safety shutoff electronic flame sensing controls. All controls shall be listed for operation at low outdoor air temperatures. Inspection of burner flame shall be possible thru observation port. shall be A.G.A. design certified for outdoor installation.

Air Movers — Twin centrifugal conditioned air blowers shall have permanently lubricated ball bearings, adjustable belt drives and be capable of delivering cfm at an external static pressure of inches water gauge requiring not more than bhp and rpm. Motor shall be inherent protection.

Propeller type condenser fans shall discharge vertically and be direct driven by a hp motor. Fan motors shall be permanently lubricated and inherently protected. Fans shall have a safety guard.

Frame and Casing — The frame shall be welded construction. The casing shall be of galvanized panels with a baked on outdoor enamel finish. The entire bottom of cabinet shall be insulated with 1" thick fiberglass insulation. Cabinet panels shall be insulated with not less than 1-1/2" thick fiberglass. Openings shall be provided for power connection entry. Lifting lugs shall be provided for easy rigging.

Air Filters — Cleanable filters furnished shall have not less than sq. ft. of free area.

Service Access — All components, wiring and inspection areas shall be completely accessible through removable panels.