

GSR21Q "PULSE21"™ SERIES HORIZONTAL/DOWN-FLO GAS FURNACES HORIZONTAL UNIT HEATERS AND DOWN-FLO MOBILE HOME UNITS

*91.7% to 95.3% A.F.U.E.

50,000 to 100,000 Btuh Input

Add-On Cooling — 1-1/2 thru 5 Nominal Tons

*Isolated Combustion System Rating for Non-Weatherized Furnaces

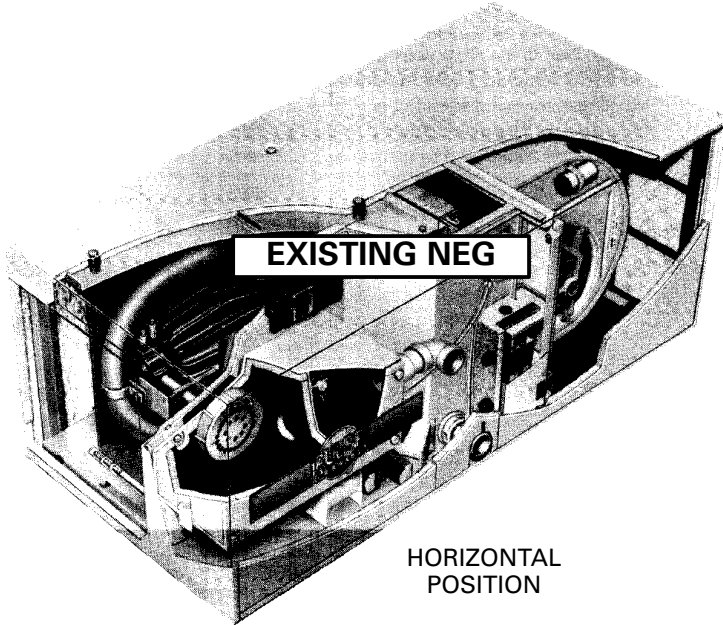

HORIZONTAL POSITION



DOWN-FLO POSITION

Typical Applications

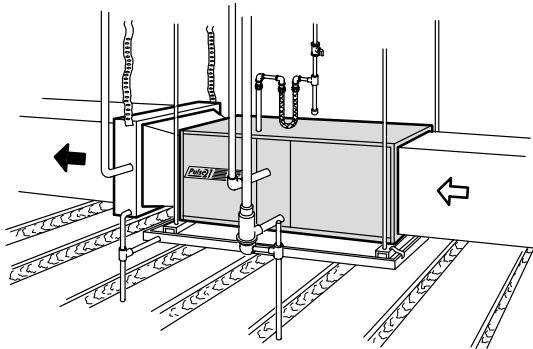

Horizontal Attic Installation

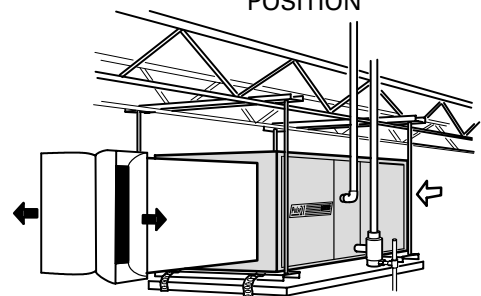

Suspended Horizontal Unit Heater Installation

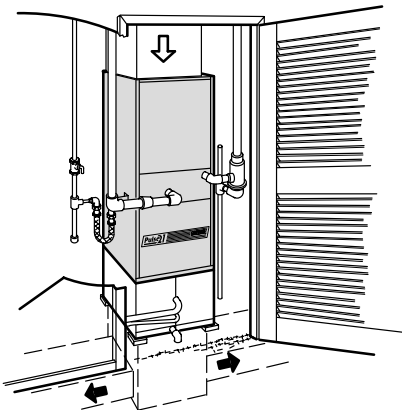

Down-Flo Mobile Home Closet Installation

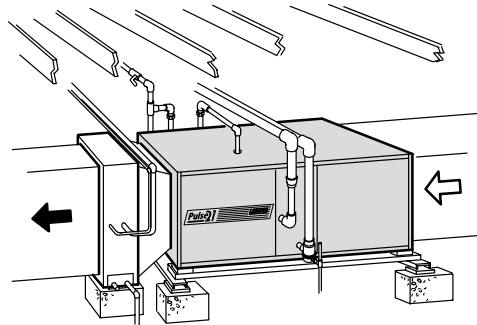

Horizontal Crawlspace Installation

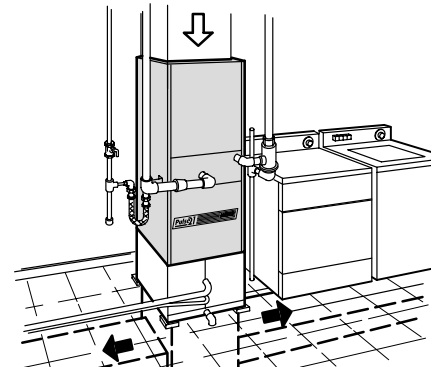

Down-Flo Utility Room Installation

PROCESS OF COMBUSTION

The process of combustion begins as gas and air are introduced into the sealed combustion chamber with the spark plug igniter. Spark from the plug ignites the gas/air mixture, which in turn causes a positive pressure buildup that closes the gas and air inlets. This pressure relieves itself by forcing the products of combustion out of the combustion chamber through the tailpipe into the heat exchanger exhaust decoupler and on into the heat exchanger coil. As the combustion chamber empties, its pressure becomes negative, drawing in air and gas for the next pulse of combustion. At the same instant, part of the pressure pulse is reflected back from the tailpipe at the top of the combustion chamber. The flame remnants of the previous pulse of combustion ignites the new gas/air mixture in the chamber, continuing the cycle. Once combustion is started, it feeds upon itself allowing the purge blower and spark plug igniter to be turned off. Each pulse of gas/air mixture is ignited at a rate of 60 to 70 times per second, producing from one-fourth to one-half of a Btu per pulse of combustion. Almost complete combustion occurs with each pulse. The force of these series of ignitions creates great turbulence which forces the products of combustion through the entire heat exchanger assembly resulting in maximum heat transfer.

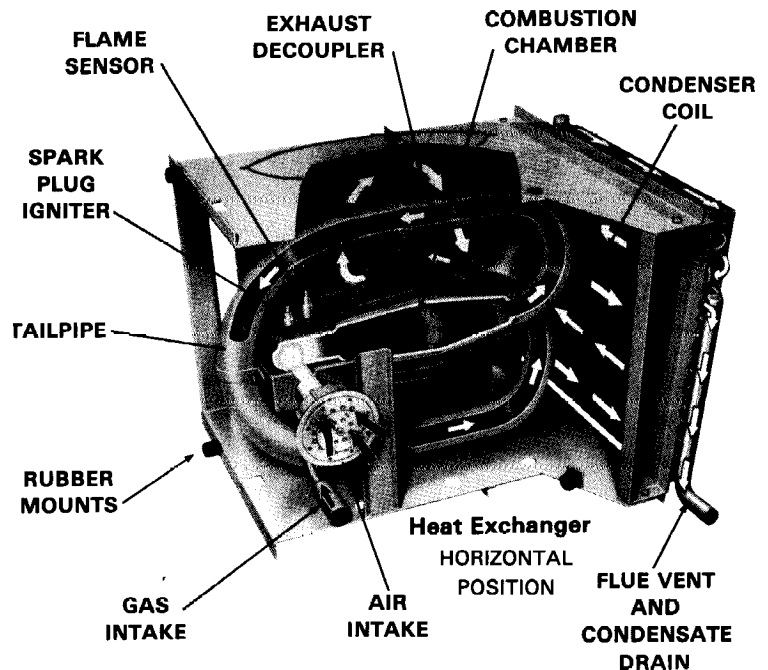

FEATURES

Application — GSR21 series pulse furnaces are designed to be installed in either horizontal or down-flo positions. Horizontal air flow is left hand air flow only. Units provide heating efficiencies (AFUE) of up to 95%. Five models (natural gas or LPG) are available with input capacities at 50,000, 80,000 and 100,000 Btuh. Units operate on the pulse combustion principle and do not require a pilot burner, main burners, conventional flue or chimney. Units can be installed in a utility room, alcove, closet, crawlspace or attic. Also, units are applicable as horizontal unit heaters in non-ducted systems and 50,000 and 80,000 Btuh input down-flo models in mobile home applications. GSR21Q3-80, GSR21Q4/5-80 and GSR21Q4/5-100 models are applicable to the GSR21 Commercial Heat-Vent-Cool-Modular Indoor System. See page 39 in this tab section for specifications. Lennox add-on evaporator coils, electronic air cleaners and power humidifiers can easily be added for a total comfort all-season system.

High efficiency of the GSR21 series is achieved with a unique heat exchanger design which features: finned cast iron combustion chamber, temperature resistant steel tailpipe, aluminized steel exhaust decoupler section and a finned stainless steel tube condenser coil. Moisture, during the process of combustion, is condensed in the coil, extracting almost every usable Btu out of the gas. Most of the combustion heat is utilized in the heat transfer from the coil, producing flue vent temperatures as low as 100F to 130F which allows the use of PVC (polyvinyl chloride) pipe for venting. Furnace can be vented through a side wall, roof or to the top of an existing chimney with up to 35 ft. of PVC pipe and up to four 90 degree elbows. Condensate created in the coil (PH ranges from 4.0 to 6.0) is not harmful to standard household plumbing and can be drained into city sewers and septic tanks without damage.

The GSR21 furnace has no pilot light or burners. An automotive type spark plug is used for ignition on the initial cycle only, saving gas and electrical energy. In the pulse combustion process, the use of atmospheric burners is eliminated, with combustion confined to heat exchanger combustion chamber. Sealed combustion system virtually eliminates the loss of conditioned air due to combustion and stack dilution. Combustion air is piped to the furnace with same type PVC pipe as used for exhaust gases.

Furnace is equipped with a standard type redundant gas valve in series with a gas expansion tank and gas intake flapper valve. Also factory installed are an air intake flapper valve, purge blower, spark plug igniter, flame sensor with solid-state control, solid-state blower control, dual limit controls, high and low voltage terminal strip, 30VA transformer

and cleanable air filter. Furnished for field installation are a flexible gas line connector, (4) isolation mounting pads, base insulation pad and condensate drip leg.

Optional equipment available are: flue vent/air intake line roof or wall termination installation kits, LPG conversion kits, down-flo additive base, horizontal support frame kit, mufflers, heat cable kit and thermostat.

GSR21 units are shipped completely factory assembled with all controls installed and wired. Units are test fired at the factory to insure proper operation.

Approvals — GSR21 series furnaces are certified by A.G.A. Laboratories as central furnaces and horizontal unit heaters. 50,000 and 80,000 Btuh input down-flo models have mobile home approval. Ratings are certified by GAMA. Units meet the California Nitrogen Oxides (NO_x) standards and California Seasonal Efficiency requirements. In addition, units have been rated and tested in the Lennox Research Laboratory according to Department of Energy (DOE) test procedures and Federal Trade Commission (FTC) labeling regulations. Blower data is from unit tests conducted in the Lennox Laboratory air test chamber.

Equipment Warranty — GSR21 "Pulse" heat exchangers have a limited lifetime warranty. Solid-state ignition modules have a limited warranty for three years. All other components have a limited warranty for one year. Refer to Lennox Limited Equipment Warranty certificate included with the equipment for details.

Sequence of Operation — Room thermostat, on a demand for heat, will initiate purge blower operation for a pre-purge cycle (30 seconds) followed by energizing and opening of the gas valve. As ignition occurs, the flame sensor reacts to proof of ignition and de-energizes the spark plug igniter and purge blower. Furnace blower operation is initiated 45 seconds after combustion ignition. When thermostat is satisfied, gas valve is closed and purge blower is re-energized for a post-purge cycle (34 seconds). Furnace blower will remain in operation until the "fan off" factory setting of 180 seconds (adjustable from 120 to 240 seconds) is reached. Should loss of flame occur before thermostat is satisfied, flame sensor controls will initiate 5 attempts at re-ignition before locking out unit operation. Additionally, loss of either combustion intake air or flue exhaust will automatically terminate system operation. If unit becomes locked out, Watchguard circuit on GC3 ignition control will automatically reset ignition controls after one hour of continuous thermostat demand.

FEATURES

Heat Exchanger Assembly — Lennox developed heat exchanger assembly consists of combustion chamber, tailpipe, exhaust decoupler section and condenser coil. Combustion chamber contains the spark plug igniter, flame sensor and combustion air and gas intake manifolds. Cast iron construction provides excellent radiation of heat over entire surface area. Finned "teardrop" shape design permits total air coverage of all surfaces with low resistance. Tailpipe connects the combustion chamber to the exhaust decoupler section. Precisely sized and shaped tailpipe is constructed of combination stainless and aluminized steel for superior resistance to high temperatures. Aluminized steel resonator on tailpipe minimizes combustion sound. Heavy gauge aluminized steel exhaust decoupler section has large surface area for maximum heat transfer. Air foil shape design results in complete air coverage with minimum air resistance. Condenser coil intake header connects to bottom of exhaust decoupler section. Large face area and circuiting of coil provides high heat transfer, minimum air resistance and proper moisture drainage. Coil is constructed of exactly spaced ripple-edged aluminum fins fitted to stainless steel tubes. Flared collars on fins grip tubes for maximum contact area. Flared tubing connections and high temperature brazing provide tight, leakproof joints. Combined flue vent and condensate drain outlet is located on the coil. Coil is factory tested for leaks. All components are mounted in a heavy gauge steel frame and installed in the furnace cabinet on resilient rubber mounts assuring quiet, vibration free operation. Heat exchanger has been laboratory life cycle tested.

Rugged Cabinet — Constructed of heavy gauge cold rolled steel. Cabinet is subject to a five station metal wash process resulting in a perfect bonding surface for a paint finish of baked-on enamel. The paint solution and metal are given opposite electrical charges resulting in positive adhesion and even coverage of the paint to the metal surfaces. Heat exchanger section is completely lined with thick (1-1/2 lb./ft.³ density) foil faced fiberglass insulation. Blower compartment is completely lined with thick (1-1/2 lb./ft.³ density) black mat faced fiberglass insulation. This results in quiet and efficient operation due to the excellent acoustical and insulating properties of fiberglass. Complete service access is accomplished by removing heating section and blower access panels. Removable panel is provided in vestibule panel for access to the spark plug and flame sensor. Safety interlock switch automatically shuts power off to unit when blower access panel is removed. Electrical inlets, gas line inlets, air intake and exhaust air outlets are provided in the cabinet.

Powerful Blowers — Units are equipped with quiet multi-speed direct drive blowers. Each blower assembly is statically and dynamically balanced. Slide-out blower assembly is equipped with jack-plug connection for easy removal for servicing. Multiple-speed leadless motor is resiliently mounted. A choice of blower speeds is available on each blower. See blower performance tables. Change in blower speed is easily accomplished by simple wiring change.

Cleanable Air Filters — Washable or vacuum cleanable frame type filter is furnished as standard. Polyurethane media is coated with oil for maximum efficiency. Filter is readily accessible in unit for quick and easy removal for servicing.

Combustion Air Intake Box — Contains the purge blower and air intake flapper valve. Box is located on vestibule panel. Purge blower is equipped with a permanently lubricated motor. Blower operates only during pre-purge and post-purge cycles. Air is drawn through the blower during the combustion cycle by negative pressure in the combustion chamber. Pressure switches terminate unit operation in case of air intake or flue exhaust blockage. Flapper valve air housing is constructed of an elastomeric non-metallic polymer which reduces operating sound levels. Flapper valve section of the box is completely lined with 1 inch thick (6 lb./ft.³ density) duct liner board, black neoprene coated fiberglass. Valve opening and closing is actuated by back pressure and negative pressure in combustion chamber during the heating cycle. Differential pressure switch, mounted on the vestibule panel, terminates unit operation in case of air intake or flue exhaust blockage.

GC3 Ignition Control — Solid-state control provides power for spark plug igniter. Also controls pre-purge and post-purge cycles and re-ignition sequence if loss of flame occurs. Also features Watchguard circuit. Solid-state control provides automatic reset of ignition controls after 1 hour of continuous thermostat demand after unit lockout. Ignition control is factory installed on the vestibule panel.

Automatic Gas Valve, Expansion Tank and Gas Intake Flapper Valve — 24 volt redundant dual gas control valve combines gas pressure regulation and manual main shutoff valve into one compact combination control. Dual valve design provides double assurance of 100% close off of gas on each heating cycle. Expansion tank is located downstream from the gas valve and absorbs any pressure pulsations. Gas intake flapper valve is installed in the combustion chamber intake manifold between the orifice and expansion tank. Valve is opened by entering gas pressure and closed by back pressure from combustion pulse during the heating cycle.

Wiring Junction Box — Power supply and thermostat connections are made at the wiring junction box located on the vestibule panel. Box contains 30 VA transformer, high and low voltage terminal strips and blower cooling relay. Terminal strip permits easy connections for optional power humidifiers and electronic air cleaners. Blower cooling relay activates blower operation for add-on air conditioning cooling.

Solid-State Blower Control — Circuit board located in wiring junction box contains all necessary controls to automatically operate the blower. Contains blower timed-on control (45 seconds fixed) and adjustable blower timed-off control (120 to 240 seconds). Factory setting is 180 seconds.

Dual Limit Controls — Factory installed and accurately located upstream and downstream of the heat exchanger. Primary and secondary limit controls provide protection from abnormal operating conditions. Primary control is automatic reset, secondary is manual reset.

Installation Recommendations — Lennox recommends the following installation procedures to minimize any vibration transmitted from furnace during operation. Place (4) neoprene rubber isolation mounting pads (furnished) and/or base insulation pad (furnished), 1 inch thick (1-1/2 lb./ft.³ density) fiberglass, under the unit. Install flexible duct connectors in the supply air plenum and return air plenum or duct connection. Insulate (1 inch thick, 1-1/2 to 3 lb./ft.³ density, mat faced fiberglass) supply and return air plenums through take-off or duct elbow. Use flexible gas connector (furnished) in gas supply piping where allowed by local codes. Insulate (refrigerant piping insulation or equivalent) all straps and hangers used in suspending ducts, electrical conduit, gas piping, combustion air intake piping and flue exhaust piping. In addition, use plastic pipe or tubing for drain line from the condensate coil drip leg (furnished) to the drain, do not use copper tubing.

OPTIONAL ACCESSORIES (Must Be Ordered Extra)

In-Line Mufflers (Optional) — Two mufflers LB-52057CA (67F81) are optional and must be ordered extra. Mufflers field install, vertical or horizontal, one in the intake line and one in the exhaust line. See dimension drawings. Two mufflers are required on -80 & -100 units.

LPG Conversion Kits (Optional) — 100,000 Btuh input model requires a LPG conversion kit LB-83176CM (73H60) for field changeover from natural gas. Kit is not furnished and must be ordered extra. 50,000 and 80,000 Btuh input models are shipped with the LPG orifice furnished as standard for field conversion. See specifications table.

Thermostat (Optional) — Heating thermostat is not furnished and must be ordered extra. See Thermostats bulletin in Accessories Section. For all-season applications, heating-cooling thermostat is available with the condensing unit.

Continuous Low Speed Blower Kit (Optional) — Field installed kit LB-83611B (89H88) is available to provide continuous low speed blower operation. Kit includes switch and all necessary wiring. Kit is not furnished and must be ordered extra.

GSR21-50 Low Ambient Thermostat Kit (Optional) — Kit LB-58659CA (70G49) prevents GSR21-50 unit from short cycling (run times of less than 4 or 5 minutes) when system thermostat is set at 55 degrees F or less. Kit contains low temperature thermostat and relay with mounting bracket, mounting screws and necessary wires. Thermostat field installs in return air stream on blower housing. Must be ordered extra.

Down-Flo Additive Base (Optional) — Additive base is required for heating only models installed on combustible floors. Base is not furnished and must be ordered extra for field installation. See specifications table. Not required in add-on cooling coil applications.

OPTIONAL ACCESSORIES (Must Be Ordered Extra)

Horizontal Support Frame Kit (Optional) — Kit provides support of the unit in horizontal applications. Kit consists of (2) 1" x 1-1/2" x 32-5/8" and (2) 1" x 3" x 53-7/8" painted, heavy gauge cold rolled steel support channels with assembly and suspending holes. Bolts and nuts are furnished for field assembly of channels. Suspending rods must be furnished by installer. Kit is not furnished and must be ordered extra. See specifications table.

Condensate Drain Heat Cable Kits (Optional) — Self-limiting wattage heat cable prevents condensate drain from freezing when unit is installed in unconditioned space. Kit LB-56539DA (**38G80**) has 100 ft. of heat cable. Kit LB-56496DA (**39G01**) contains 25 ft. of heat cable. Splicing Kit LB-56530DA (**39G02**), available for connecting cable, makes two splices. Installation Kit LB-56497CA (**38G81**) contains necessary installing hardware.

Concentric Vent/Intake Air Roof/Wall Termination Kit (Optional) — Facilitates installation of combustion air intake pipe and flue exhaust pipe. Kit LB-49107CE (**60G77**) contains concentric termination assembly, mounting clamp, roof flashing, reducer bushing and 45 degree elbow. Kit requires single hole penetration of roof or wall for installation. Kit is A.G.A. certified and must be ordered extra for field installation. See dimension drawings.

Vent/Intake Air Wall Termination Kit (Optional) — Facilitates installation of combustion air intake pipe and flue exhaust pipe. Kit must be ordered extra. Select one of the following:

- 1 — Kit LB-49107CB (**15F74**) contains 2 stainless steel outside seal caps, 2 galvanized steel inside seal caps, 4 seal rings for the caps and 18 inch insulation sleeve for sealing and isolating intake and exhaust piping penetration of wall. Maintain a maximum of 6 inches between the inlet and outlet openings in the installation of the pipes. See dimension drawings.
- 2 — Kit LB-49107CD (**22G44**) consists of close-couple side-by-side PVC piping with galvanized steel wall cover plate for sealing and isolating piping penetration of the wall. Piping spacing and length is sized for proper wall installations. A.G.A. certified. See dimension drawings.

Vent/Intake Air Roof Termination Kit (Optional) — Facilitates installation of combustion air intake pipe and flue exhaust pipe. Kit contains two neoprene rubber roof flashings and 18 inch insulation sleeve for sealing and isolating intake and exhaust piping penetration in roof. Kit LB-49107CC (**15F75**) must be ordered extra for field installation. See dimension drawings.

SPECIFICATIONS

Model No.		GSR21Q3-50	GSR21Q4-50	GSR21Q3-80	GSR21Q4/5-80	GSR21Q4/5-100
Input Btuh		50,000	50,000	80,000	80,000	100,000
Output Btuh		47,000	47,000	71,000	72,000	92,000
*A.F.U.E.		94.8%	95.3%	91.7%	94.1%	92.0%
California Seasonal Efficiency		89.7%	90.1%	87.6%	88.6%	87.3%
Temperature rise range (°F)		30 — 60	25 — 55	40 — 70	30 — 60	45 — 75
High static certified by A.G.A. (in wg.)		.50	.50	.50	.50	.50
Gas Piping Size I.P.S. (in.)	Natural	1/2	1/2	1/2	1/2	1/2
	•LPG	1/2	1/2	1/2	1/2	1/2
Vent/Intake air pipe size connection (in.)		2	2	2	2	2
Condensate drain connection (in.) SDR11		1/2	1/2	1/2	1/2	1/2
Blower wheel nominal diameter x width (in.)		10 x 8	10 x 10	10 x 10	12 x 12	12 x 12
Blower motor hp		1/3	1/2	1/3	3/4	3/4
Number and size of filters (in.)		(1) 20 x 25 x 1				
Tons of cooling that can be added		1-1/2 — 3	3-1/2 — 4	2 — 3	3-1/2 — 5	3-1/2 — 5
Shipping weight (lbs.)		311	316	317	329	335
Number of packages in shipment		1	1	1	1	1
Electrical characteristics		120 volts — 60 hertz — 1 phase (less than 12 amps) All models				
LPG kit (optional)		**Furnished				•LB-83176CM (73H60)
Optional Horizontal Support Frame Kit — Ship. Weight		LB-56495CA (39G05) (All Models) — 18 lbs.				
Optional Down-Flo Additive Base — Shipping Weight		LB-80639BB (68387) (All Models) — 6 lbs.				

•LPG kit must be ordered extra for field changeover.

*Annual Fuel Utilization Efficiency based on D.O.E. test procedures and according to F.T.C. labeling regulations. Isolated combustion system rating for non-weatherized furnaces.

**LPG orifice furnished as standard with unit for field changeover. Convertible gas valve requires simple adjustment without adding any parts. See installation instructions.

A.G.A. INSTALLATION CLEARANCES

DOWN-FLO

Sides	1 inch
Rear	1 inch
Top	1 inch
Front	6 inches
*Floor	*Combustible
Flue Pipe	0 inches

* Clearance for installation on combustible floor if optional additive base is installed between furnace and combustible floor. Not required in add-on cooling coil applications if installed in accordance with local codes or National Fuel Gas Code ANSI-Z223.1.

HORIZONTAL

Ends	3 inches
Rear	3 inches
*Top	*3 inches
Front	6 inches
Floor	Combustible
Flue Pipe	0 inches

* Line contact installation permissible between jacket top or sides and building joists.

BLOWER DATA

GSR21Q3-50 BLOWER PERFORMANCE

External Static Pressure (in. wg)	Air Volume (cfm) @ Various Speeds			
	High	Med-High	Med-Low	Low
0	1640	1405	1070	875
.05	1620	1390	1065	870
.10	1595	1375	1060	865
.15	1570	1360	1055	860
.20	1545	1345	1045	855
.25	1520	1325	1035	850
.30	1490	1305	1025	840
.40	1430	1260	995	810
.50	1365	1200	960	775
.60	1285	1135	910	735
.70	1195	1055	840	----
.80	1085	955	755	----

NOTE — All cfm data is measured external to unit with the air filter in place.

GSR21Q4-50 BLOWER PERFORMANCE

External Static Pressure (in. wg)	Air Volume (cfm) @ Various Speeds			
	High	Med-High	Med-Low	Low
0	1935	1725	1530	1225
.05	1900	1695	1515	1220
.10	1865	1665	1490	1210
.15	1825	1630	1465	1195
.20	1790	1595	1435	1175
.25	1745	1560	1400	1140
.30	1700	1520	1365	1105
.40	1585	1420	1285	1030
.50	1470	1320	1200	975
.60	1360	1215	1115	920
.70	1235	1115	1030	----
.80	1105	1000	930	----

NOTE — All cfm data is measured external to unit with the air filter in place.

GSR21Q3-80 BLOWER PERFORMANCE

External Static Pressure (in. wg)	Air Volume @ Various Speeds		
	High	Medium	Low
0	1735	1455	1095
.05	1720	1445	1090
.10	1700	1435	1085
.15	1675	1420	1080
.20	1640	1405	1070
.25	1615	1385	1060
.30	1585	1355	1045
.40	1520	1290	995
.50	1440	1210	930
.60	1330	1120	870
.70	1180	1015	----
.80	1035	900	----

NOTE — All cfm data is measured external to unit with the air filter in place.

GSR21Q4/5-80 BLOWER PERFORMANCE

External Static Pressure (in. wg)	Air Volume (cfm) @ Various Speeds				
	High	Med-High	Medium	Med-Low	Low
0	2355	2205	1965	1740	1520
.05	2325	2175	1940	1715	1495
.10	2290	2150	1920	1695	1475
.15	2255	2115	1890	1670	1450
.20	2220	2085	1860	1645	1425
.25	2185	2050	1830	1620	1400
.30	2150	2020	1800	1595	1375
.40	2080	1950	1745	1540	1320
.50	2000	1880	1680	1475	1260
.60	1915	1805	1615	1410	1195
.70	1825	1720	1540	1330	----
.80	1730	1635	1460	1240	----

NOTE — All cfm data is measured external to unit with the air filter in place.

GSR21Q4/5-100 BLOWER PERFORMANCE

External Static Pressure (in. wg)	Air Volume (cfm) @ Various Speeds				
	High	Med-High	Medium	Med-Low	Low
0	2275	2140	1940	1725	1520
.05	2245	2110	1915	1700	1490
.10	2215	2075	1885	1675	1465
.15	2185	2040	1860	1645	1435
.20	2150	2005	1830	1620	1410
.25	2115	1970	1805	1590	1380
.30	2075	1935	1775	1560	1350
.40	1990	1870	1710	1500	1290
.50	1925	1800	1645	1435	1235
.60	1835	1730	1570	1370	1175
.70	1760	1650	1490	1300	----
.80	1675	1570	1400	1225	----

NOTE — All cfm data is measured external to unit with the air filter in place.

DOWN-FLO POSITION

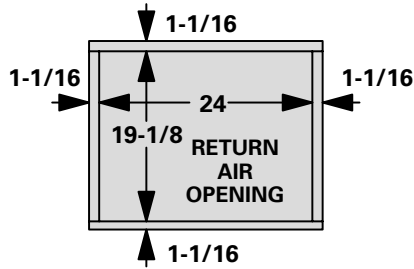

NOTE – When heating only unit is installed on a combustible floor, an additive base is required. This is optional equipment and must be ordered extra. When using additive base, make opening in floor 2-5/8 inches larger (front to rear and side to side) than furnace supply air opening.

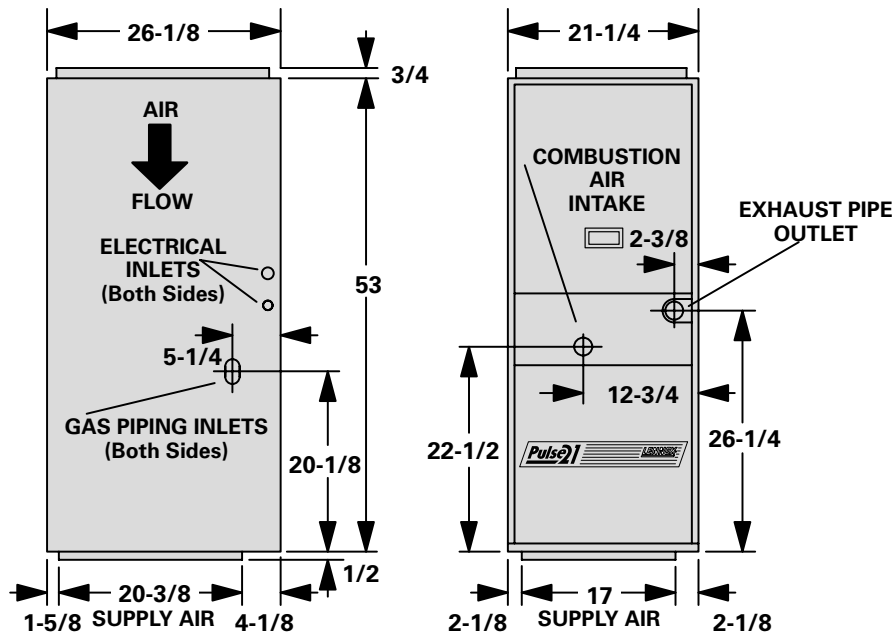

HORIZONTAL POSITION

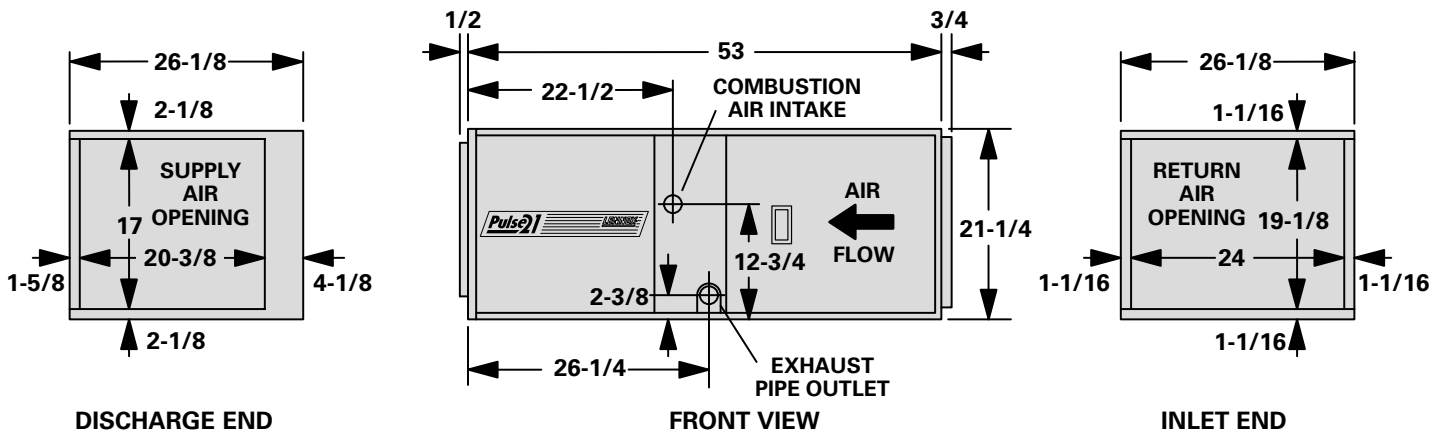
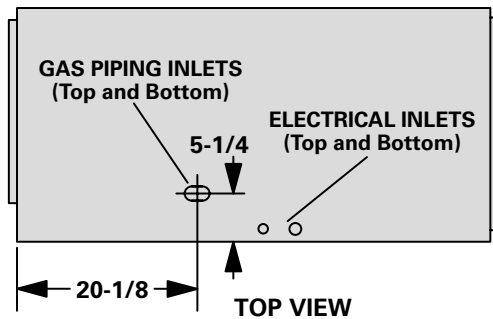

**IN-LINE MUFFLERS
(LB-52057CA)**

NOTE — Two mufflers are furnished per order no.

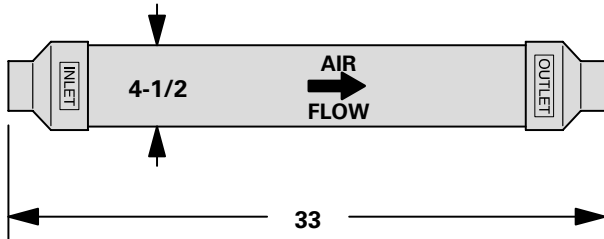

**CONCENTRIC ROOF/WALL
TERMINATION KIT
(LB-49107CE)**

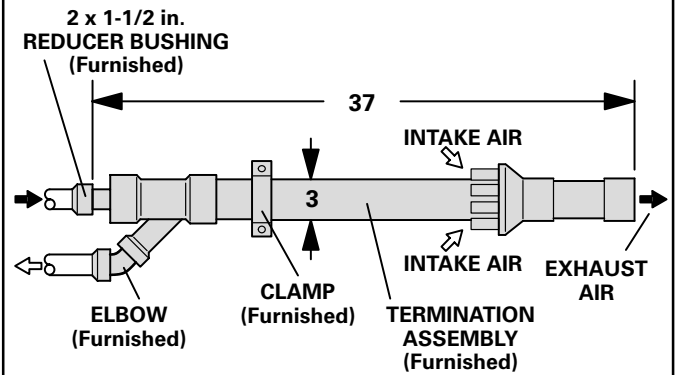

**CONCENTRIC WALL
TERMINATION APPLICATIONS**

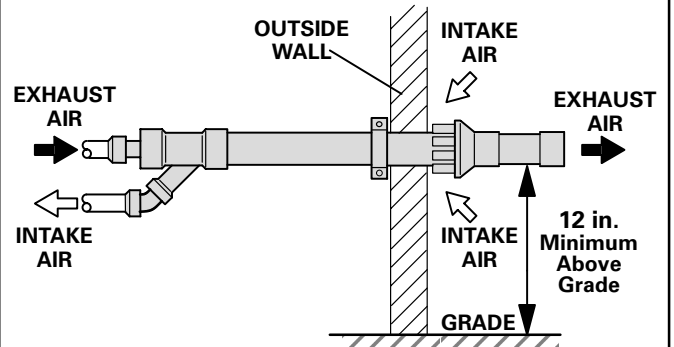

**ROOF TERMINATION KIT
(LB-49107CC)**

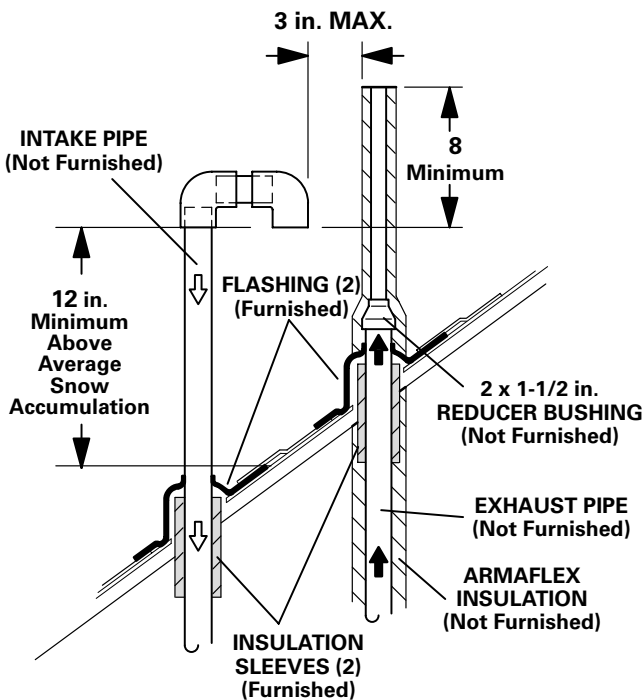

**CONCENTRIC ROOF
TERMINATION APPLICATIONS**

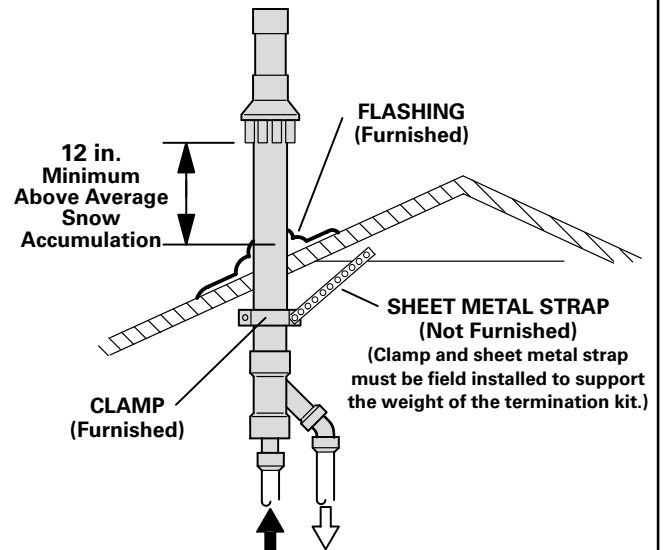

OPTIONAL ACCESSORY DIMENSIONS (inches)

